

MAHLE CAD-6KCMS

EN

Operation Manual
Cummins Diesel Engine
Adapter:
NH, NTC, NTE, N14, 855,
378 V6 & L10 6 Cylinder,
504, 555, 903, KT 1150
Series Engines

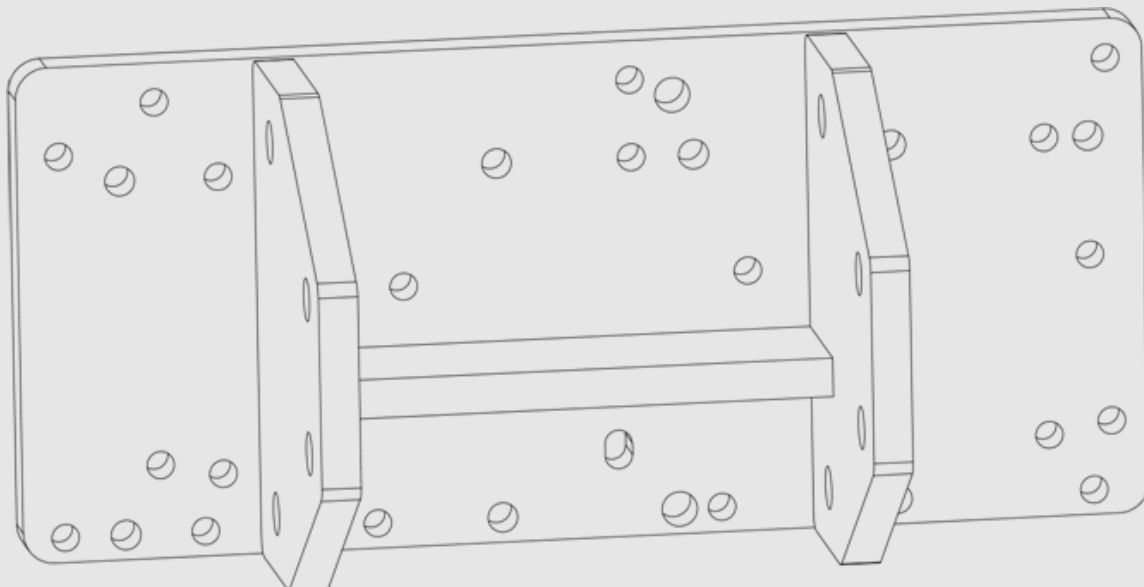



**EVERY PERSON WHO OPERATES THIS
EQUIPMENT NEEDS TO KNOW AND
UNDERSTAND ALL OF THE INFORMATION IN
THIS MANUAL – FAILURE TO DO SO COULD
RESULT IN SERIOUS INJURY OR DEATH.**

**READ THIS MANUAL
CAREFULLY AND
RETAIN FOR YOUR
RECORDS**

Contents

1. Safety Regulations	4
1.1 Warnings.....	4
2. Foreword.....	5
2.1 From the manufacturer.....	5
3. Symbols Use.....	5
3.1 Signal words	5
4. Responsibilities	6
4.1 Receiving inspection	6
4.2 Owner and/or operator responsibilities.....	6
5. Specifications	6
6. Operation.....	7
6.1 Mounting an Engine	7
6.2 Dismounting an Engine.....	7
7. Notes.....	8

1. Safety Regulations

1.1 Warnings

- ⚠ Failure to follow all of these safety instructions can lead to severe injury or death from a sudden loss of the load. Contact the manufacturer using the contact information provided if you have any questions.
- ⚠ Maximum capacity is 4,400 lbs. Do not exceed. Overloading can result in equipment failure.
- ⚠ Never use parts, attachments, or accessories that have not been provided by the manufacturer. Do not use hardware with a lower grade than what is provided by the manufacturer.
- ⚠ No alterations shall be made to this product.
- ⚠ Never load engine stand abruptly. Load engine stand slowly and carefully.
- ⚠ Never allow the engine's center of gravity to be misaligned with the engine stand's axis of rotation. Ensure engine is fully secured to Engine Adapter Plate before placing on stand.
- ⚠ Always apply the locking screws when stand is being loaded and/or remaining stationary.
- ⚠ Always use engine stand on a hard level surface. Be sure surface is clean and free of debris, cracks, and chips. Avoid any uneven or dirty surfaces when moving loaded engine stand.
- ⚠ Never mount an engine that makes the stand unstable.

tech.mss@us.mahle.com with any comments or questions.

2. Foreword

2.1 From the manufacturer

Thank you for your purchase. To complement the offering of A/C, fluid and nitrogen service equipment, MAHLE Service Solutions has partnered with Gray Manufacturing to provide the highest quality hydraulic and pneumatic equipment available for the professional service technician. This equipment adheres to high standards promised in the MAHLE guarantee including the assurance of innovation and reliability that comes with the Gray Manufacturing name. Please contact MAHLE Service Solutions' customer service at (800) 468-2321 or tech.mss@us.mahle.com with any comments or questions.

3. Symbols Use

3.1 Signal words

Signal words call attention to a safety message or messages, or a property damage message or messages, and designate a degree or level of hazard seriousness. Signal words used in this manual include:

Keyword	Probability of occurrence	Severity of danger if instructions not observed
DANGER	Immediate impending danger	Death or severe injury.
WARNING	Possible impending danger	Death or severe injury
CAUTION	Possible dangerous situation	Minor injury
NOTICE	Possible damage to property	Possible property damage

4. Responsibilities

4.1 Receiving inspection

Before attempting to operate this equipment, thoroughly read and understand this manual. Completely remove all tape and packaging. Inspect the equipment immediately upon delivery. If shipping damage is evident, inform the delivering carrier immediately and contact the manufacturer using the contact information on the back cover of this manual.

4.2 Owner and/or operator responsibilities

The owner of this equipment must read these instructions and maintain them for future reference and for instructing any other users of the equipment. The owner is responsible for keeping all warning labels and instruction manuals legible and intact. Replacement labels and literature are available from the manufacturer. The owner must never authorize or allow anyone to use this equipment until the operator has read and understood the information in this manual and on the accompanying labeling on the equipment itself.

If this equipment is being used in an occupational setting (or workplace), the employer should ensure that all personnel working with and around the equipment know of the risks associated with its use. Personnel involved in the use and operation of this equipment shall be careful, competent, trained, and qualified in the safe operation of the equipment and its proper use when servicing motor vehicles and their components. Safety information provided with this equipment should be emphasized by the employer and understood by each employee. The employer must make this manual available to all personnel using this equipment and all personnel must read and understand the contents of this manual. If the operator is not fluent in English, the manufacturer's instructions and warnings shall be read to and discussed with the operator in the operator's native language by the employer, making sure that the operator comprehends its contents and observes the proper procedures for use of this equipment.

5. Specifications

Model CAD-6KCMS	US units	Metric units
Capacity	4,400 lb.	1996 kg
Weight	60 lb.	27.2 kg
Overall width	13.25 in	33.7 cm
Overall length	26 in	66 cm
Overall height	9 in	23 cm

6. Operation

6.1 Mounting an Engine

1. Prepare the engine to be mounted to the stand. Remove all components that will be in the way of attaching the Engine Adapter Plate to the engine.
2. Attach Engine Adapter Plate to the side of the engine, making sure bolts are securely fastened.
3. Using a shop crane or other suitable means, move the engine into position for attaching to the adapter extension plates.
4. Align the engine's center of gravity within 2" of the engine stand's axis of rotation by raising or lowering the engine. Align the adapter extension plates with the closest 5/8-11UNC holes of the adapter adjuster plate. Secure the adapter extension plates to the adapter adjuster plate on the engine stand. Torque bolts to 120 ft-lbs.
5. Slowly transfer the engine's weight to the engine stand.

⚠ CAUTION! If the engine or stand shifts, moves, or rotates check that the engine's center of gravity is in line with the engine stand's axis of rotation and that all hardware is properly tightened. If something seems wrong, remove the engine stand from service and inspect it according to the Inspection Instructions in the manual provided with the engine stand.

6. Rotate gear box crank handle to rotate engine. Use jack and jack handle to raise and lower the engine as necessary. When engine stand is stationary, use locking screws to prevent the engine stand from moving.

6.2 Dismounting an Engine

1. Prepare engine for moving and engine's destination for accepting engine.
2. Be sure the Locking Screws are lowered, and the engine stand does not move.
3. Using a shop crane or other suitable means, capture engine and transfer engine's weight to equipment being used to move engine. Follow

instructions provided with equipment being used to move engine.

4. Carefully detach Engine Adapter Plate from the adapter extension plates.

7. Notes

MAHLE

MAHLE Aftermarket Inc.
916A West State Street
St. Johns, MI 48879 U.S.A.

Phone: (800) 468-2321
Fax: (717) 755-8304
E-mail: tech.mss@us.mahle.com

www.servicesolutions.mahle.com