

MAHLE CAD-DPFH

EN

Operation Manual
Horizontal DPF adapter

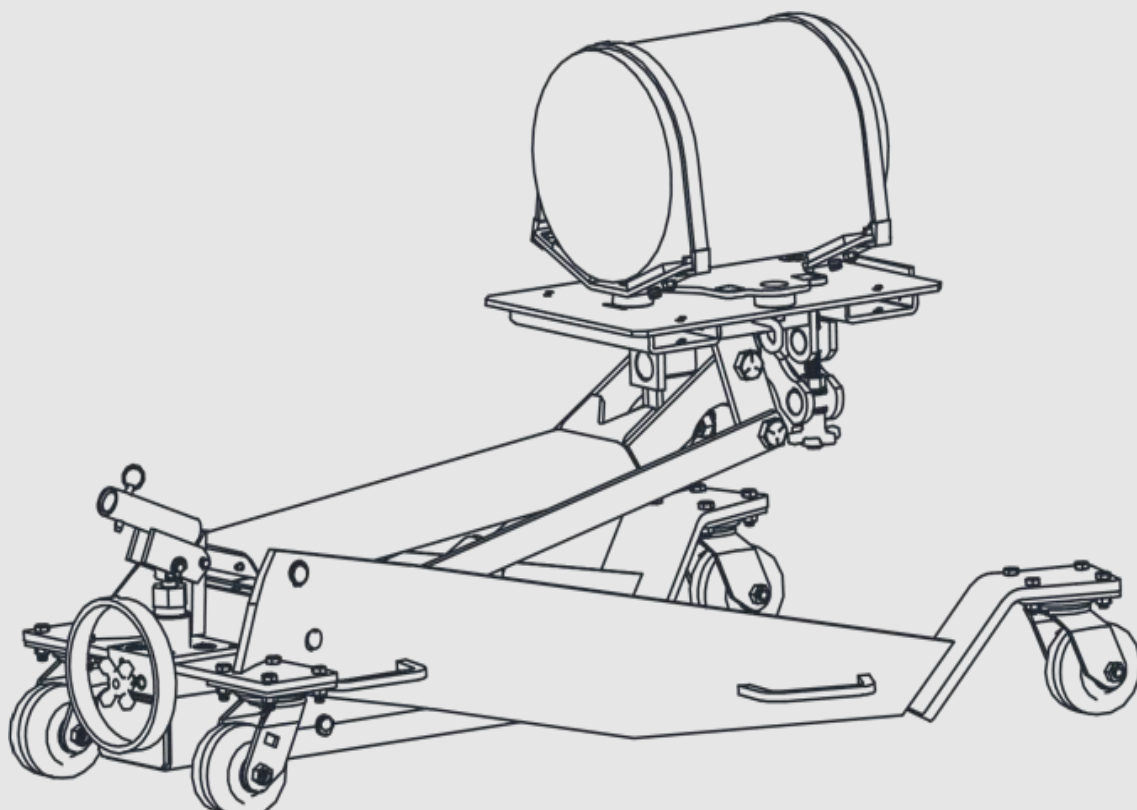



**EVERY PERSON WHO OPERATES THIS
EQUIPMENT NEEDS TO KNOW AND
UNDERSTAND ALL OF THE INFORMATION IN
THIS MANUAL – FAILURE TO DO SO COULD
RESULT IN SERIOUS INJURY OR DEATH.**

**READ THIS MANUAL
CAREFULLY AND
RETAIN FOR YOUR
RECORDS**

Contents

1. Safety Regulations	4
1.1 Warnings.....	4
2. Foreword.....	5
2.1 From the manufacturer.....	5
3. Symbols Use.....	5
3.1 Signal words.....	5
4. Responsibilities	6
4.1 Receiving inspection	6
4.2 Owner and/or operator responsibilities.....	6
5. Operation.....	7
5.1 Handling a DPF using the DPF Adapter	7
5.2 WARNING.....	7
6. Notes	8

1. Safety Regulations

1.1 Warnings

Read and understand all of the instructions and warnings on the on-product labeling and in the owner's manuals of the jack and the adapter before using the adapter.

- ⚠ Do not exceed the capacity of the adapter
- ⚠ Use adapter only for its intended purpose
- ⚠ Handle the DPF with care. Do not allow it to experience impact or excessive force

2. Foreword

2.1 From the manufacturer

Thank you for your purchase. To complement the offering of A/C, fluid and nitrogen service equipment, MAHLE Service Solutions has partnered with Gray Manufacturing to provide the highest quality hydraulic and pneumatic equipment available for the professional service technician. This equipment adheres to high standards promised in the MAHLE guarantee including the assurance of innovation and reliability that comes with the Gray Manufacturing name. Please contact MAHLE Service Solutions' customer service at (800) 468-2321 or tech.mss@us.mahle.com with any comments or questions.

3. Symbols Use

3.1 Signal words

Signal words call attention to a safety message or messages, or a property damage message or messages, and designate a degree or level of hazard seriousness. Signal words used in this manual include:

Keyword	Probability of occurrence	Severity of danger if instructions not observed
DANGER	Immediate impending danger	Death or severe injury.
WARNING	Possible impending danger	Death or severe injury
CAUTION	Possible dangerous situation	Minor injury
NOTICE	Possible damage to property	Possible property damage

4. Responsibilities

4.1 Receiving inspection

Before attempting to operate this equipment, thoroughly read and understand this manual. Completely remove all tape and packaging. Inspect the equipment immediately upon delivery. If shipping damage is evident, inform the delivering carrier immediately and contact the manufacturer using the contact information on the back cover of this manual.

4.2 Owner and/or operator responsibilities

The owner of this equipment must read these instructions and maintain them for future reference and for instructing any other users of the equipment. The owner is responsible for keeping all warning labels and instruction manuals legible and intact. Replacement labels and literature are available from the manufacturer. The owner must never authorize or allow anyone to use this equipment until the operator has read and understood the information in this manual and on the accompanying labeling on the equipment itself.

If this equipment is being used in an occupational setting (or workplace), the employer should ensure that all personnel working with and around the equipment know of the risks associated with its use. Personnel involved in the use and operation of this equipment shall be careful, competent, trained, and qualified in the safe operation of the equipment and its proper use when servicing motor vehicles and their components. Safety information provided with this equipment should be emphasized by the employer and understood by each employee. The employer must make this manual available to all personnel using this equipment and all personnel must read and understand the contents of this manual. If the operator is not fluent in English, the manufacturer's instructions and warnings shall be read to and discussed with the operator in the operator's native language by the employer, making sure that the operator comprehends its contents and observes the proper procedures for use of this equipment.

5. Operation

5.1 Handling a DPF using the DPF Adapter

1. Thread the 1/2-13 capscrews into the adapter.
2. Use the 1/2-13 nuts to secure the adapter to the jack's lift platform.
3. Remove the adjustable brackets from the jack's lift platform if necessary.
4. Slowly raise the adapter to the DPF taking care not to crush the DPF.
5. Ensure the DPF is centered on the adapter.
6. Disconnect DPF from vehicle and allow it to rest on the adapter.
7. Strap the DPF to the adapter to prevent it from falling or shifting.
8. Lower the DPF and remove the jack from under the vehicle.
9. After work has been completed, reverse steps to reinstall DPF.

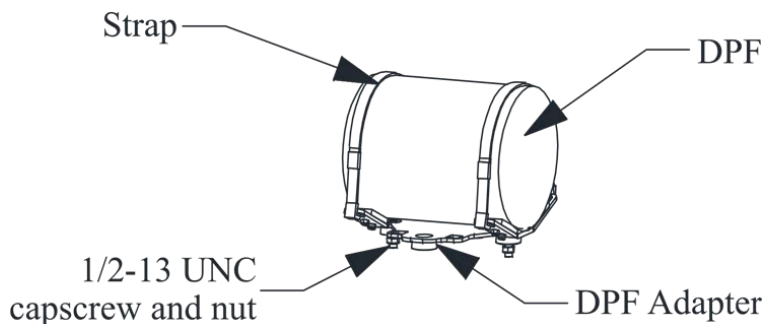

5.2

⚠ WARNING!

1. Read and understand all of the instructions and warnings on the on-product labeling and in the owner manuals of the jack and the adapter before using the adapter.
2. Do not exceed the capacity of the adapter.
3. Use adapter only for its intended purpose.
4. Handle the DPF with care. Do not allow it to experience impact or excessive force.

6. Notes

MAHLE

MAHLE Aftermarket Inc.
916A West State Street,
St. Johns, MI 48879 U.S.A.

Phone: (800) 468-2321
Fax: (717) 755-8304
E-mail: tech.mss@us.mahle.com

www.servicesolutions.mahle.com

670-90863_A