

MAHLE CFL-7

EN

Operation Manual
Walking beam forklift jack





**EVERY PERSON WHO OPERATES THIS
EQUIPMENT NEEDS TO KNOW AND
UNDERSTAND ALL OF THE INFORMATION IN
THIS MANUAL – FAILURE TO DO SO COULD
RESULT IN SERIOUS INJURY OR DEATH.**

**READ THIS MANUAL
CAREFULLY AND
RETAIN FOR YOUR
RECORDS**

Contents

1. Safety Regulations	4
1.1 Warnings.....	4
2. Foreword	5
2.1 From the manufacturer	5
3. Symbols Use	5
3.1 Signal words	5
4. Responsibilities	6
4.1 Receiving inspection.....	6
4.2 Owner and/or operator responsibilities	6
5. Specifications	6
5.1 CFL-7.....	6
6. Product Description	7
6.1 Component identification.....	7
6.2 Release knob	7
6.3 2 Speed pump	7
7. Operation	8
7.1 Inspect the jack for signs of wear or damage.....	8
7.2 Transport the jack to the work area	8
How to wheel the jack.....	8
How to lift and carry the jack	8
7.3 Select appropriate support stands and bring them to the immediate work area.....	8
7.4 Prepare the surrounding area before using the jack	9
7.5 Identify a lift point, prepare the load for lifting, and chock wheels	9
7.6 Raise the forklift	10
7.7 Use appropriate support stands	10
7.8 Lower the forklift	10
8. Maintenance and Inspection	11
8.1 Inspection – before each use	11
8.2 Maintenance instructions	11
8.3 Pump priming instructions	12
9. Troubleshooting	13
10. Maintenance Chart	14
11. Notes	15

1. Safety Regulations

1.1 Warnings

⚠ Failure to follow all of these safety instructions can lead to severe injury or death from a sudden loss of the load. Contact the manufacturer at the numbers or address printed on the back cover of this manual if you have any questions.

⚠ **Anyone who operates this product must read and understand all the instructions and warnings provided with this stand before being allowed to use it.** All operators must be careful, competent, trained, and qualified in the safe operation of the jack. The owner (or other responsible individual) must ensure that any operator observes the proper safety procedures for using this stand at all times. If the operator does not read well or is not fluent in English, the owner / manager must read and review the instructions and warnings in the manual with the operator in the operator's native language to be sure that the operator will use the jack properly.

⚠ **The owner / manager must keep this manual for future reference,** and make sure the warning labels on the product are legible and intact at all times. Replacement labels and manuals are available from the manufacturer. Call the manufacturer using the contact information on the back cover of this manual if you have any questions.

⚠ **Always use appropriate support stands to support a forklift after it has been raised.** This jack is a lifting device only! Never perform any work on or around a forklift or allow any part of your body under a raised load until the forklift is properly supported by support stands and the jack is removed from the work area. If lifting the forklift from the front or rear, the wheels remaining on the ground must be chocked.

⚠ **Use this jack only to raise forklifts.** This jack is not designed to raise loads other than forklifts. Using this lift to raise loads other than forklifts can result in serious injury or death. Never use a forklift jack on a forklift while the motor is running.

⚠ **Never use this jack in conjunction with any other jack or lift.** Never use this jack to raise one side (or end) of a forklift unless the other side (or end) of the forklift is in contact with the ground.

⚠ **Make sure the load does not exceed the maximum capacity of the stand.** Maximum capacity is 15,435 lbs / 7,000 kg. Do not exceed. If you need to lift more than this, use a jack that has a higher maximum capacity. Never use more than one jack to raise a forklift.

⚠ **Never use this jack to lower a vehicle if the vehicle was raised using another lifting device or devices.** You should lower the vehicle with the same equipment that was used to properly raise it (read and follow warnings and instructions for this other equipment).

⚠ **Never use parts, attachments, or accessories that have not been provided by the manufacturer.** Do not use hardware with a lower grade than what is provided by the manufacturer.

⚠ **Never modify the product in any way.** Modifications may cause the stand to perform improperly, resulting in injury or death.

⚠ **Always use caution while operating this device** and remain mindful of how the device and load will react during operation of this device.

⚠ **Protect hands, feet, and other body parts when using or transporting the jack.** Keep hands, feet, and all other body parts out of the area of the scissors mechanism at all times during use or transport of the jack. The scissors action of the lifting mechanism can cause serious injury to body parts.

⚠ **Never abuse or cause damage to the jack.** Never subject the stand to abnormal shocks or loads. Your safety and that of others depends on the proper operation of the stand.

2. Foreword

2.1 From the manufacturer

Thank you for your purchase. To complement the offering of A/C, fluid and nitrogen service equipment, MAHLE Service Solutions has partnered with Gray Manufacturing to provide the highest quality hydraulic and pneumatic equipment available for the professional service technician. This equipment adheres to high standards promised in the MAHLE guarantee including the assurance of innovation and reliability that comes with the Gray Manufacturing name. Please contact MAHLE Service Solutions' customer service at (800) 468-2321 or tech.mss@us.mahle.com with any comments or questions.

3. Symbols Use

3.1 Signal words

Signal words call attention to a safety message or messages, or a property damage message or messages, and designate a degree or level of hazard seriousness. Signal words used in this manual include:

Keyword	Probability of occurrence	Severity of danger if instructions not observed
DANGER	Immediate impending danger	Death or severe injury.
WARNING	Possible impending danger	Death or severe injury
CAUTION	Possible dangerous situation	Minor injury
NOTICE	Possible damage to property	Possible property damage

4. Responsibilities

4.1 Receiving inspection

Before attempting to operate this equipment, thoroughly read and understand this manual. Completely remove all tape and packaging. Inspect the equipment immediately upon delivery. If shipping damage is evident, inform the delivering carrier immediately and contact the manufacturer using the contact information on the back cover of this manual.

4.2 Owner and/or operator responsibilities

The owner of this equipment must read these instructions and maintain them for future reference and for instructing any other users of the equipment. The owner is responsible for keeping all warning labels and instruction manuals legible and intact. Replacement labels and literature are available from the manufacturer. The owner must never authorize or allow anyone to use this equipment until the operator has read and understood the information in this manual and on the accompanying labeling on the equipment itself.

If this equipment is being used in an occupational setting (or workplace), the employer should ensure that all personnel working with and around the equipment know of the risks associated with its use. Personnel involved in the use and operation of this equipment shall be careful, competent, trained, and qualified in the safe operation of the equipment and its proper use when servicing motor vehicles and their components. Safety information provided with this equipment should be emphasized by the employer and understood by each employee. The employer must make this manual available to all personnel using this equipment and all personnel must read and understand the contents of this manual. If the operator is not fluent in English, the manufacturer's instructions and warnings shall be read to and discussed with the operator in the operator's native language by the employer, making sure that the operator comprehends its contents and observes the proper procedures for use of this equipment.

5. Specifications

5.1 CFL-7

Model CFL-7	US units	Metric units
Maximum capacity	15,435 lbs	7,000 kg
Maximum lift height	16 in	40.6 cm
Reach (raised position) (dist. from hyd. cyl. to lift pad)	7 in	17.8 cm
Width	10 in	25.4 cm
Starting pad height (lift arm notch)	2.25 in	5.7 cm
Starting pad height (serrated pad)	2.5 in	6.4 cm
Weight	92 lb	41.7 kg

6. Product Description

6.1 Component identification

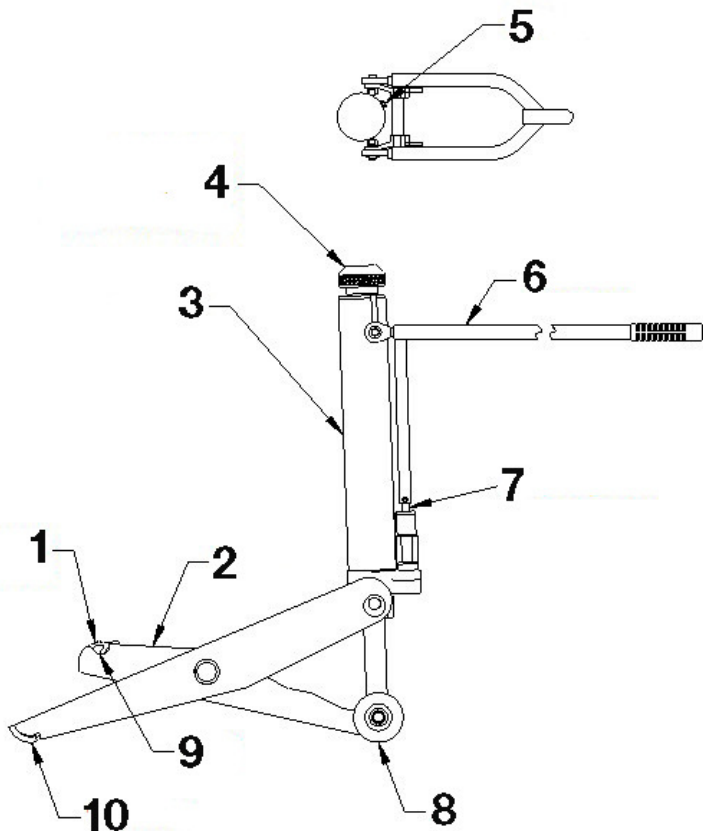

Fig. 1: CFL-7 side view

- 1 Serrated lift pad
- 2 Lift arm
- 3 Reservoir
- 4 Release knob (spring loaded)
- 5 Fill plug
- 6 Pump handle
- 7 Pump plunger shaft
- 8 Wheels
- 9 Lift arm notch
- 10 Front footpad

6.2 Release knob

- ❗ The release knob has a “Hold-to-Run™” feature that utilizes a heavy-duty return spring to automatically close the release valve when the operator “lets go” of the release knob. With this feature, the operator should never have to physically close the valve by turning the release knob in a clockwise direction.
- ❗ A mechanical stop prevents turning the release knob more than 1/2 turn counterclockwise.
- ⚠ **WARNING!** Never remove this mechanical stop. Never force the release knob more than 1/2 turn counterclockwise as doing this may damage the release knob’s return spring.
- ❗ If the valve ever behaves as if it is not completely closing (e.g., the jack won’t raise or won’t hold a load), the operator may gently turn the release knob in a clockwise direction until resistance is felt. The jack should then raise when the lift arm is pumped. If it does not, please contact the manufacturer using the contact information on the back cover of this manual for assistance.

6.3 2 Speed pump

This jack is equipped with a two-speed pump. If it is in high speed mode, the pad will raise about one inch for each handle stroke. If the pad moves a ¼ inch per handle stroke, the pump is in the low speed mode. To shift to the high speed mode, pull up on the handle until you feel it detent. It may be necessary to put your foot on the rear wheels to cause it to detent. The pump will automatically shift to the low speed mode when the pad starts lifting the load. There will be a noticeably abrupt change due to the difference in pumping rates. (When you first contact the load, lift the pump all the way up. This will make the shift from high to low speed much smoother.

7. Operation

⚠ WARNING - This section discusses the appropriate and safe methods for using the jack. Failure to follow all of the steps outlined in this section could result in serious injury or death.

7.1 Inspect the jack for signs of wear or damage

1. Before each use, inspect the jack for any visible signs of wear or damage. See the “Inspecting the jack” section for details about how to inspect the jack.

⚠ If you see any signs of wear or damage, or if there is any indication that the jack is not performing normally, immediately take it out of service and contact the manufacturer using the contact information on the back cover of this manual. Never use a jack that appears damaged in any way.

7.2 Transport the jack to the work area

1. Transport the jack to the work area by either (a) wheeling it or (b) lifting and carrying it. The lift should always be wheeled to the work area if possible—only lift and carry the jack if it cannot be wheeled safely. Wheel the jack only across smooth surfaces. If the surface is rough or uneven, lift and carry the jack instead of wheeling it.

⚠ Jolting caused by the wheels catching on uneven surfaces can cause physical strain and personal injury.

How to wheel the jack

1. Make sure the surface over which the jack will be wheeled is smooth. If the surface is rough or uneven, lift and carry the jack instead of wheeling it (see “How to Lift and Carry the Jack” below).
2. Insert the jack pump handle into the socket and lock it into place using the quick-release locking pin (see Fig. 2) immediately after inserting it into the socket.

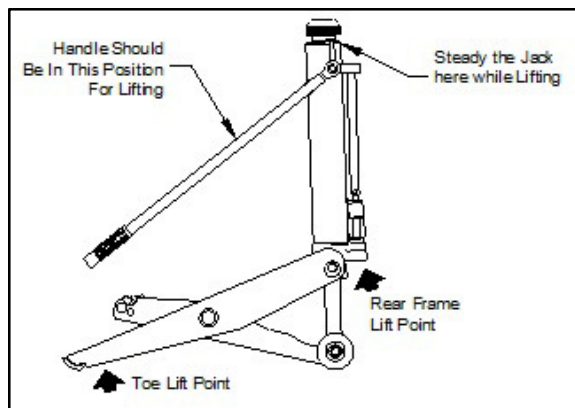

Fig. 2: Lock handle in place to wheel and/or lift jack

⚠ WARNING! Never transport the jack with an unsecured pump handle.

3. Pull handle away from jack and rotate to desired position. For wheeling (transporting) the jack place handle in the vertical position (see Figure 3).

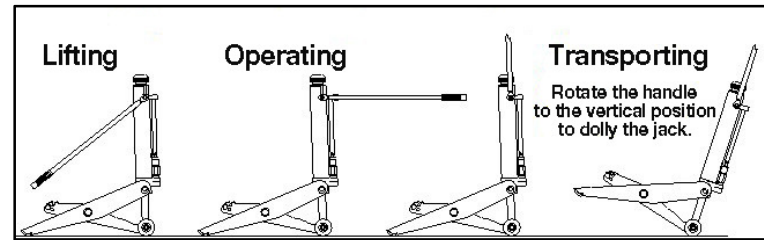

Fig. 3: Handle positions

4. Place foot on back wheels. Pull back on the pump handle to raise the front footpad off the floor and allow the jack to roll freely on its wheels.

How to lift and carry the jack

1. Identify the proper lift points on the jack (see Fig. 2). The jack should be lifted using both the toe lift point and the rear frame lift point.

⚠ Never use the pump handle to lift the jack. The pump handle is not a properly balanced leverage point for lifting the jack. In addition, a pump handle that is not properly pinned into the socket (with the quick release locking pin) may slip out of the socket and cause the jack to fall.

2. Lift and carry the jack. Whenever possible, have someone else help you lift and carry the jack. The jack weighs 92 lb (41.7 kg).

⚠ Do not attempt to lift the jack if you have any physical condition that prevents you from safely lifting this amount of weight. If you weigh less than 150 pounds, never lift the jack without assistance.

⚠ Always use proper lifting techniques- squat, keep back straight, and use legs to do the lifting. Never bend your back or lift the jack with your back.

7.3 Select appropriate support stands and bring them to the immediate work area

ⓘ It is important that support stands are used.

⚠ Use appropriate stands to support the load immediately after lifting. Never use the jack to support a load. Failure to follow all of these instructions can result in jack instability and loss of a load.

7.4 Prepare the surrounding area before using the jack

- ❗ It is important that surrounding area is properly prepared before raising a load.
- ⚠ Use the jack only on hard, level surfaces capable of safely supporting the load.
- ⚠ The jacks front footpad and rear wheels must always remain in direct contact with the floor.
- ⚠ Never attempt to lift from a polished or greasy floor.
- ⚠ Clear the surrounding area of personnel, tools, equipment, and make sure appropriate support stand and chocks are available for use in the immediate area.
- If these conditions cannot be met, move the forklift and jack to an area where the lift can be performed safely.

7.5 Identify a lift point, prepare the load for lifting, and chock wheels

- ❗ Before lifting a forklift with a jack, you need to identify a lift point and prepare the load for lifting.
- 1. Remove any load from the forks of the forklift and lower the forks to the ground.
- 2. Identify a lift point at the rear or side of the forklift.
- ⚠ Position the jack so as the forklift is lifted, the load will be balanced on the forklift tires that remain on the ground.
- ⚠ When raising a forklift from one end, always chock the wheels that will remain on the ground.
- ⚠ Make sure at least two wheels of the forklift remain in contact with the floor at all times. Never raise a 3-wheeled forklift from the 2-wheeled end or from the side. Never use the jack to raise all four wheels of the forklift from the floor. Never raise the forklift higher than 15° if using the serrated lift pad or 1/4 its tread width (See Fig. 4 and 5).

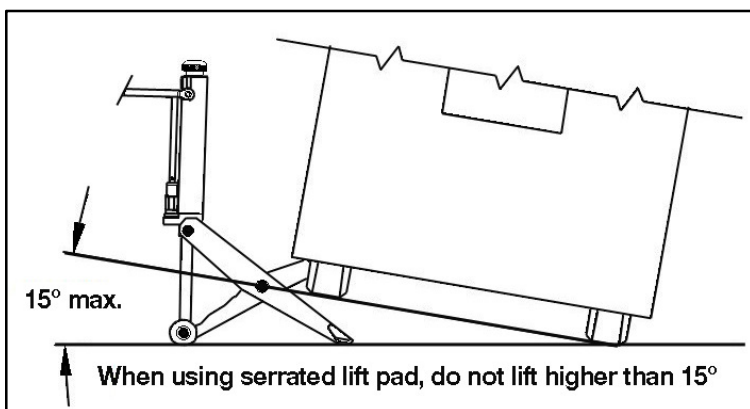

Fig. 4: Using serrated lift pad

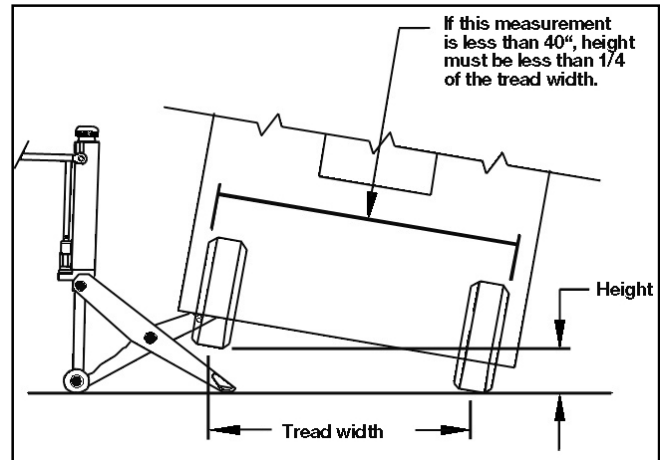

Fig. 5: Lifting height versus forklift width

- 3. Examine the lift point carefully and ensure that it is strong enough to resist the lifting force of the jack without damaging the forklift or machinery.
- It is preferred to lift the forklift at a point where a structural member will be cradled in the lift arm notch at the end of the lift arm (see Fig. 6).

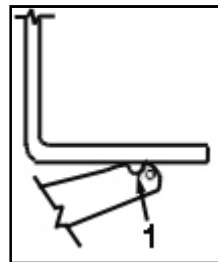

Fig. 6: Using lift arm notch to cradle a support point

1 Lift notch arm

- If no structural component on the forklift is present at the desired lifting point, weld a steel bar to the forklift to create a structural member (as in Fig. 6).
- If no structural component exists and one cannot be created, flip the serrated lift pad into an upward position and choose a lift point at least 3" inward toward the center of the vehicle on a flat surface (see Fig. 7).

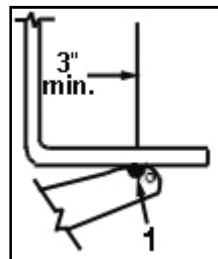

Fig. 7: Using serrated lift pad

1 Serrated lift pad

- The serrated lift pad or lift arm notch must be in direct contact with the forklift (see Fig. 8)

- ⚠ Never increase the lifting height of the jack by putting wood, pads, cinder blocks, or any other objects above the lift pad or underneath the front footpad and/or wheels (Fig. 8).

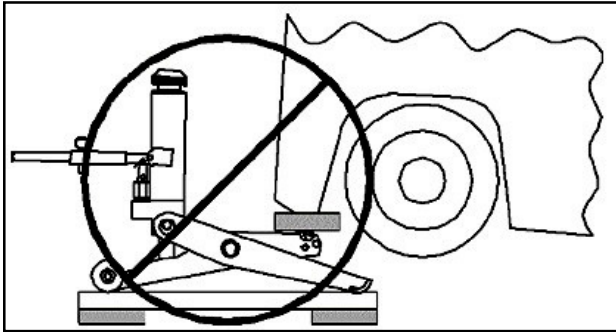

Fig. 8: Never increase lifting height

- ⚠ Never use any other area on the jack as a contact point (Fig. 9).

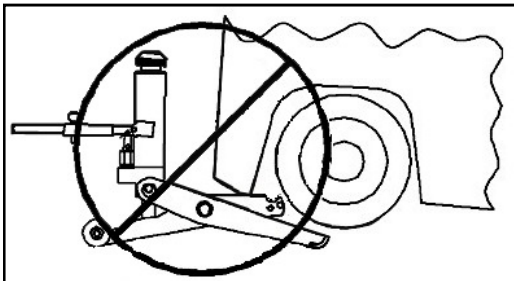

Fig. 9: Only use the notch/lift pad to lift forklift

- The jack's front footpad and rear wheels must ALWAYS remain in direct contact with the floor (see Fig. 4).
- ⚠ Never lift with the jack positioned under a sloped or rounded surface, such as the bottom surface of a forklift's counterweights (Fig. 10).

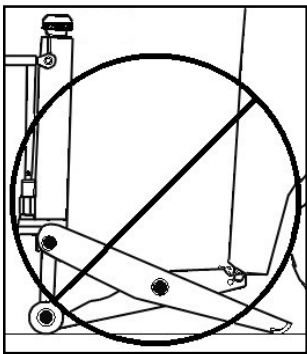

Fig. 10: Do not lift on rounded surface

- ⚠ Never push the jack under the load past the "red line" marked on the decal located on top of the lift arm.
- ⚠ Never lift the forklift by its counterweight
- ⚠ Never lift the forklift in a manner that is counter to the manufacturer's recommendations.

7.6 Raise the forklift

1. Make sure forklift is not running before raising the forklift.
 2. If lifting the forklift from the front or rear, the wheels remaining on the ground must be chocked.
 3. Select a lift point as outlined in "Identify a lift point" section.
 4. Make sure appropriate support stands and chocks are available for use in the immediate work area.
 5. Make sure the handle is in the horizontal (operating) position so that the jack can be pumped to raise the forklift (see Fig. 2).
 6. Carefully begin pumping the jack handle to raise the load.
- ⚠ Never raise the forklift higher than 1/4 its tread width when using the serrated lift pad (see Fig. 4).

7.7 Use appropriate support stands

- ⚠ This jack is a lifting device only. Use appropriate stands to support the load immediately after lifting. Never use the jack to support a load. Never allow any part of your body under the raised load until it is properly supported by stands.
1. When the forklift has been raised to the desired height, place appropriate support stands under the forklift to support it according to the forklift manufacturer's recommendations. Read and follow all instructions and warnings provided with the support stands.
 2. Lower the forklift onto the stands by slowly turning the release knob on the jack counterclockwise.
 3. Remove the jack and move it away from the work area before starting work.
 4. Chock the wheels that will remain on the ground

7.8 Lower the forklift

- ⚠ To avoid serious injury or death, never drive the forklift off the jack or attempt to move a forklift that it is elevated by the jack.
1. Use the instructions from section 7.6 (Raise the forklift) to raise the forklift off the jack stands.
 2. Carefully remove the stands from beneath the forklift and place them away from the work area.
 3. Slowly turn the release knob counterclockwise to lower the forklift to the floor.
- ⚠ Turn the release knob slowly to prevent the possibility of the jack from kicking out from under the forklift.
4. Lower the jack completely and move the jack and chocks away from the work area.

8. Maintenance and Inspection

⚠ **WARNING** - The jack must be inspected according to the requirements of this section. Failure to properly inspect the jack could lead to severe injury or death. The product must be removed from service and inspected immediately if it is subjected to an abnormal load or a shock load. If any irregularities or problems are detected during an inspection, the product must be removed from service immediately and repaired. Contact the manufacturer using the contact information printed on the back cover of this manual.

8.1 Inspection – before each use

Visual inspection of the jack must be made before each use. The jack should be immediately removed from service if any of the following conditions are detected or observed:

- Inspect the serrated lift pad regularly, and remove the jack from service if it is cracked, chipped, rusted, or shows signs of wear.
- The jack should raise and lower smoothly through its full range. Inspect the lift arm for damage such as bends and / or twists.
- Check the wheels to make sure that they are not damaged and that they rotate freely.
- Make sure that all components are present on the jack and are in good operating condition.
- Verify that all warning and instructions decals are in place and legible before the jack is put back in service. If any decals are missing or illegible, contact the manufacturer for replacements.

⚠ If any irregularities or problems are detected during an inspection, the jack must be removed from service immediately and repaired. Contact the manufacturer using the contact information on the back cover of this manual.

8.2 Maintenance instructions

⚠ **WARNING** - All inspection and maintenance procedures must be performed after the jack has been removed from service. Failure to do this may result in personal injury and/or property damage.

To properly maintain the jack, perform the following procedures:

1. All warning and capacity labels should be readable and complete. If they are not, contact the manufacturer for replacement labeling. Wash external surfaces of jack, labels, and decals with a mild soap solution.
2. Lubricate all rotating and sliding portions of the jack monthly. The following lubricants are required:
 - Heavy-grade machine oil.
 - Tellus T22 hydraulic oil or equivalent.
3. Apply several drops of heavy grade machine oil to the pump plunger shaft and test the plunger for proper operation.
4. Oil the pump handle joints while operating the pump handle to work the oil in.
5. The hydraulic unit is sealed, and should never require fluid to be added to the reservoir. If fluid is needed, however, fill the reservoir as follows:
 - Place the jack in the normal upright position and turn the release knob counterclockwise to completely lower the jack.
 - Carefully clean dirt and contaminants from around the fill plug and then remove the plug
 - Add Tellus T22 hydraulic oil or equivalent to the reservoir until fluid runs out of the fill plug hole. Be extremely careful to keep the fluid contaminant free and keep dirt and contaminants out of the reservoir of the jack.
 - Reinstall fill plug.

⚠ **WARNING!** - For safe and proper performance, Tellus T22 hydraulic fluid or equivalent is required. Use of improper or contaminated fluids can damage the seals, making the jack unsafe to use, and will void the warranty. Failure to heed this warning may result in personal injury and / or property damage.

8.3 Pump priming instructions

If the jack should lose its prime for any reason, follow these steps to re-prime it:

1. With the release knob released, stroke the pump handle through 2 full cycles, slowly.
2. Raise pump handle fully up; lay the jack over on its left side, as viewed from rear. Push the pump handle “down.”
3. Stand the jack upright again, raise the pump handle to the top, lay the jack over on its left side and push the pump handle “down” again.
4. Stand the jack upright, stroke the pump handle while holding the release knob open (counterclockwise).
5. Release the release knob. The jack should operate satisfactorily.
6. Repeat the priming procedure if necessary.
7. Contact the manufacturer using the contact information on the back cover of this manual if the problem persists after three attempts to re-prime the jack.

9. Troubleshooting

This section is a list of potential problems and solutions. If the solution listed fails to correct the problem, call the manufacturer at the numbers and address printed on the back cover of this manual. Please have the model number, and serial number of your jack available. The serial number is printed on a tag located on the top of the lift arm.

Problem	Cause/Solution
Fails to lift load	<ul style="list-style-type: none"> • Low oil level; see the “Adding Hydraulic Fluid” section. • Release open; gently turn the release knob in a clockwise direction until resistance is felt. See the "Release Knob" section of this manual. • Overloaded; use larger-capacity jack.
Fails to hold load	<ul style="list-style-type: none"> • Release open, turn release knob clockwise until tight. • Jack reservoir has been contaminated with dirt. If jack reservoir has recently been filled, contamination could have been inadvertently added. Contamination could be holding the valve off the seat. Hold release open and pump handle several times to flush release.
Oil leaks	<ul style="list-style-type: none"> • Oil reservoir plug loose; tighten oil reservoir plug.

11. Notes

MAHLE

MAHLE Aftermarket Inc.

10 Innovation Drive
York, PA 17402 U.S.A.

Phone: (800) 468-2321

Fax: (717) 755-8304

E-mail: tech.mss@us.mahle.com

www.servicesolutions.mahle.com

670-90782