

OPERATION MANUAL

ATX-3 PLUS BOOST LITERS

Automatic Transmission Fluid Exchanger

WARNING

DO NOT pour anything except new transmission fluid into the fill port. Serious damage will result. Do not add more than 25 liters.

The ATX-3 PLUS BOOST must be connected to a **FULLY CHARGED 12 volt battery**. This should be the battery in the vehicle being serviced.

Do not use a battery charger to power the ATX-3 PLUS BOOST.

Use of undercharged batteries and battery chargers will damage the ATX-3 PLUS BOOST and void the warranty.



MAHLE

MAHLE Aftermarket Inc.

10 Innovation Drive
York, PA 17402
800-468-2321

www.servicesolutions.mahle.com

TABLE OF CONTENTS

Component Description	2
Safety Precautions	3
Keypad Functions	4
Cooler Mode	
Connecting to the Transmission System	6
Flush	8
Drain Pan	8
Fluid Exchange	9
-1/2 Liter	10
+1/2 Liter	10
Disconnecting from the Transmission System	10
Dipstick Mode	
Connecting to the Transmission System.....	11
Drain Pan.....	12
Fluid Exchange.....	12
-1/2 Liter.....	13
+1/2 Liter.....	13
Empty Used	13
Empty New	13
Maintenance	14
Troubleshooting.....	14
Calibration	15
Calibration of Load Cells.....	16
Parts Identification	17
Flow Diagram	18
Wiring Diagram	19
EC Declaration of Conformity for Machinery	20

Calibration - A Good Practice

The ATX-3 PLUS BOOST is the most accurate of all transmission fluid exchange equipment due to the advanced load cell technology designed into the unit.

Most operating problems are usually fixed by performing a simple calibration procedure.

A good practice is to periodically calibrate the ATX-3 PLUS BOOST to ensure optimum performance.

COMPONENT DESCRIPTION

Unpack all components. Use laminated placard to verify fitting adapter quantities.

Contact MAHLE if any items are missing or damaged.

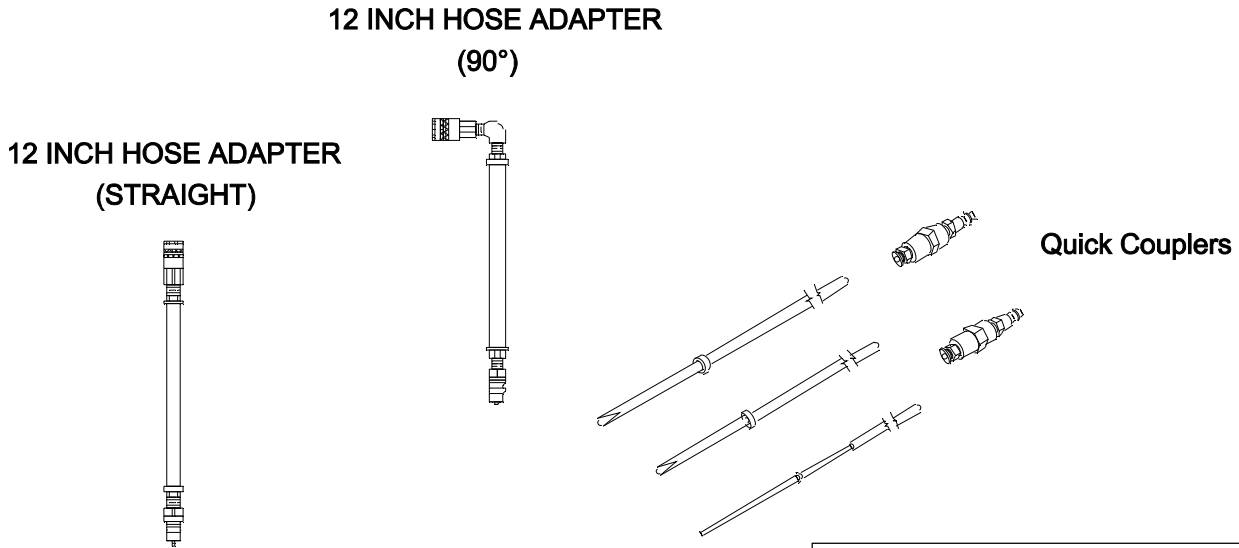

The ATX-3 PLUS BOOST includes three different diameter dip tubes, always use the largest dip tube possible for best performance.

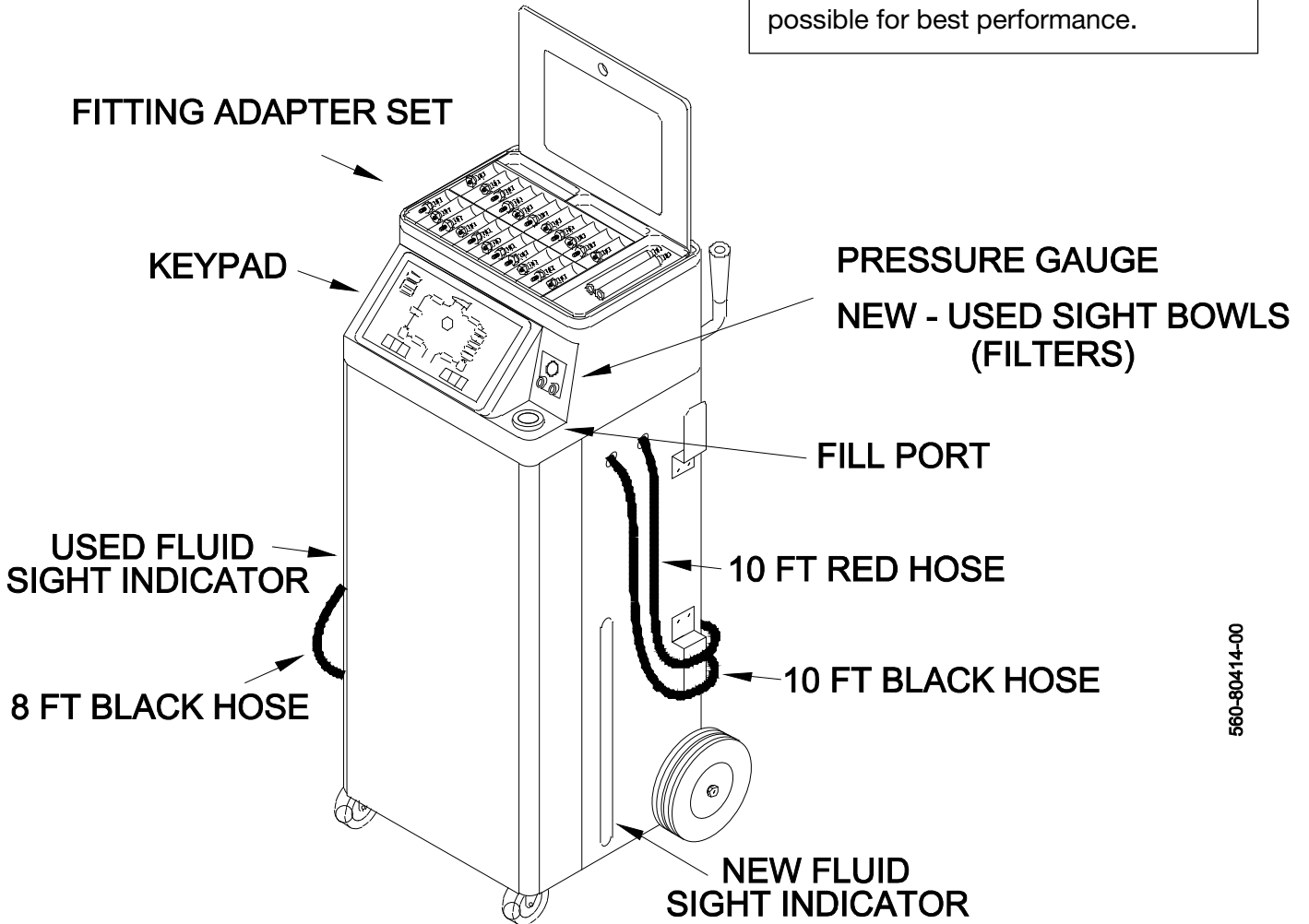

560-80414-00

SAFETY PRECAUTIONS

WARNING: Failure to follow these precautions can result in serious injury or death.

- Read and understand the Operation Manual completely before operating this unit.
- Always wear proper eye and skin protection when operating and maintaining this equipment.
- Take precautions to keep clothing, hair, hands, hoses etc. away from all moving parts of the vehicle.
- Many Automatic Transmission systems can be extremely hot and operate at high pressures. **Always use extreme caution when connecting and disconnecting hoses and adapters.**
- Always keep a fire extinguishing device nearby when working with flammable liquids.
- Choose a well-ventilated work area and avoid breathing any harmful fumes when performing a transmission fluid exchange.
- Check engine oil level and coolant level. Refill if low. Do not perform the exchange if either is low.
- Flush solutions are combustible and are harmful or fatal if swallowed. If swallowed call doctor immediately and do not induce vomiting. If Flush Solution gets in eyes flush with water immediately. For contact with skin wash with soap and water. Apply skin lotion if necessary to sooth irritation.
- Immediately clean up any transmission fluid spills and use proper container for disposal.
- Comply with local, state, and federal regulations for fluid disposal.
- **Material Safety Data Sheets** (MSDS) must be obtained on all chemicals and placed in a shop file for reference.

IMPORTANT

Check transmission fluid level according to manufacturer's instructions before connecting the ATX-3 Plus Boost

Adjust fluid level if required

KEYPAD FUNCTIONS

The ATX-3 PLUS BOOST is an automatic transmission fluid exchanger featuring state-of-the-art electronic controls with digital weight scales measuring the automatic transmission fluid coming into and going out of machine. Operation of ATX-3 PLUS BOOST is intuitive and very easy to master.

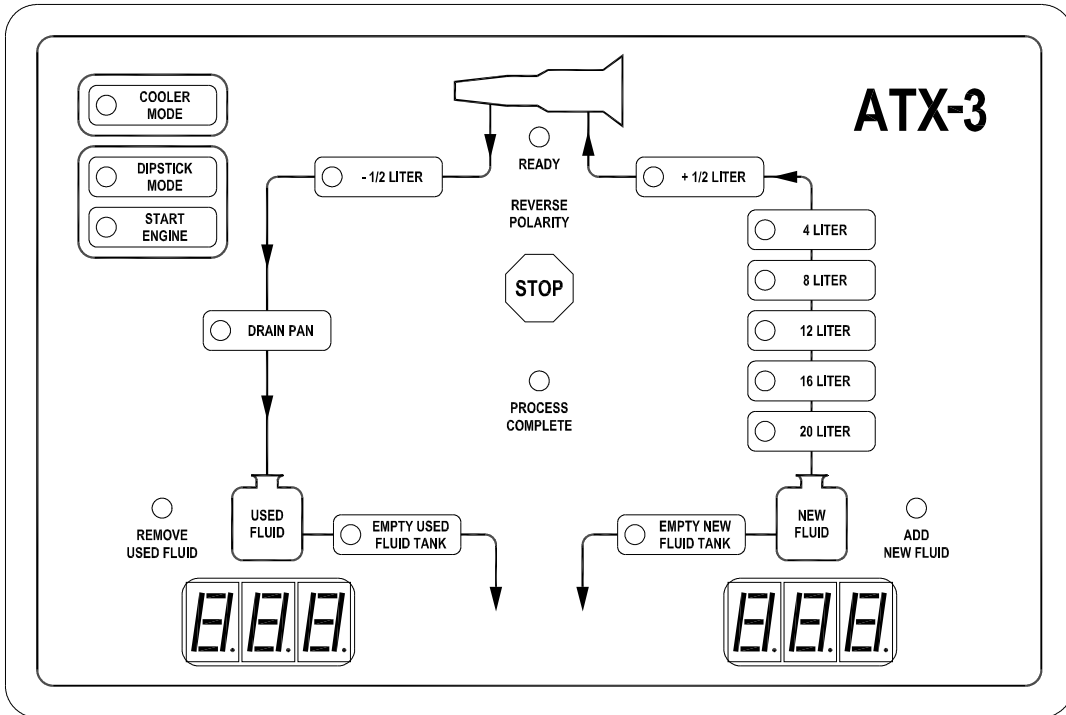

024-80149-00

DRAIN PAN

Transmission fluid is recovered from vehicle and filtered before collecting in the ATX-3 PLUS BOOST used fluid tank. When the procedure is complete, the ATX-3 PLUS BOOST buzzer will sound continuously until the stop button is pressed. Refer to page 8 for Cooler mode and page 12 for dipstick mode for complete instructions.

4 LITER

8 LITER

12 LITER

16 LITER

20 LITER

Filters and exchanges the USED transmission fluid in the vehicle for new from the ATX-3 PLUS BOOST. The procedure is complete when the buzzer sounds continuously until the stop button is pressed. Refer to page 9 for Cooler mode and page 12 for Dipstick mode for complete instructions.

EMPTY NEW FLUID TANK

Transmission fluid is emptied completely from new fluid tank inside the ATX-3 PLUS BOOST. It can be stored in a bulk container for later use. This procedure is performed if a change in transmission fluid types is required. The ATX-3 PLUS BOOST buzzer will sound continuously until stop button is pushed when procedure is complete. Refer to page 14 for complete instructions.

EMPTY USED FLUID TANK

Transmission fluid is emptied completely from the used fluid tank inside the ATX-3 PLUS BOOST into a bulk used tank for proper disposal. This procedure is performed when the used fluid tank is full or the used fluid tank capacity is not sufficient to perform selected exchange. The ATX-3 PLUS BOOST buzzer will sound continuously until the stop button is pushed when procedure is complete. Refer to page 14 for complete instructions.

KEYPAD FUNCTIONS

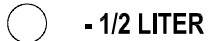

- 1/2 LITER

Used after the exchange process if fluid level is too high on the transmission dipstick. Removes ½ liter of fluid from the transmission. The ATX-3 PLUS BOOST buzzer will sound continuously until the stop button is pushed when procedure is complete. Refer to page 9 for cooler mode and page 13 for dipstick mode for complete instructions.

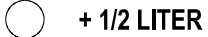

+ 1/2 LITER

Used after the exchange process if fluid level is too low on the transmission dipstick. Adds ½ liter of transmission fluid to the transmission from the ATX-3 PLUS BOOST new fluid tank. The ATX-3 PLUS BOOST buzzer will sound continuously until the stop button is pushed when procedure is complete. Refer to page 9 for cooler mode and page 13 for dipstick mode for complete instructions.



STOP

Stops any procedure the moment it is pushed, also used at the end of a procedure to acknowledge completion of process and turn buzzer off.

REVERSE
POLARITY

Illuminates when battery connection is backwards.



REMOVE
USED FLUID

Illuminates when the used tank is too full or flashes when the capacity remaining is less than exchange amount selected. The EMPTY Used procedure must be run to continue operation of the ATX-3 PLUS BOOST.



ADD
NEW FLUID

Illuminates when the new fluid tank is empty or flashes when the new fluid level is less than the selected exchange amount. The operator must add fluid to the new fluid tank of the ATX-3 PLUS BOOST through the fill port.



READY

Illuminates when the vehicle engine is running and connected properly to the ATX-3 PLUS BOOST.



PROCESS
COMPLETE

Illuminates when the selected process is complete. The buzzer will sound continuously when this is illuminated.



COOLER
MODE



DIPSTICK
MODE



START
ENGINE

The ATX-3 PLUS BOOST provides two modes of fluid exchange - Cooler or dipstick mode. The mode is selected using these buttons when the ATX-3 PLUS BOOST is powered up. During dipstick mode, the start engine button is pressed at a specified step.



Two LED readouts display the amount of fluid in the New and Used fluid tanks and give real-time readouts as the different procedures run.

Caution: Always use fingers to operate keypad. Use of sharp objects will cause damage and void the warranty.

COOLER MODE: CONNECTING TO THE TRANSMISSION SYSTEM

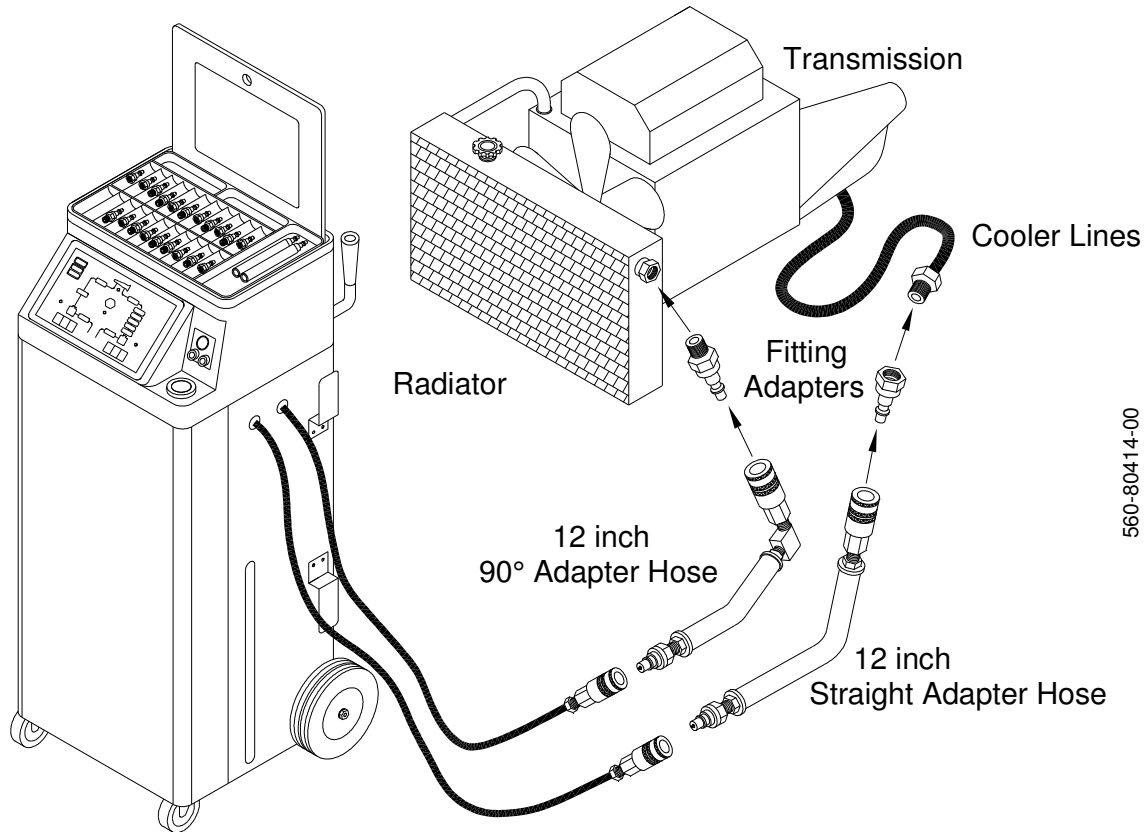

560-80414-00

IMPORTANT

Check transmission fluid level according to manufacturer's instructions before connecting the ATX-3 PLUS BOOST.

Adjust fluid level if required

1. Add desired amount of transmission fluid to the new fluid tank through the ATX-3 PLUS BOOST fill port. Monitor fluid level in the ATX-3 PLUS BOOST with the LED readouts or with fluid sight indicators. Do not pour more than 25 liters of new transmission fluid to the new fluid tank.
2. Locate and disconnect the transmission cooler lines at the most convenient location:
 - A. At cooler line connecting to radiator usually most accessible if vehicle is not on lift.
 - B. At clamped rubber hose connection to transmission cooler usually most accessible if vehicle is on a lift. Cooler is most often in front of the radiator.
 - C. At cooler line connecting to the transmission usually requires vehicle to be on a lift.

COOLER MODE: CONNECTING TO THE TRANSMISSION SYSTEM

3. Select and install proper fitting adapters to disconnect points. Use closest matching adapter and o-ring to seal any leaks if exact matching adapter cannot be found. In some cases it may be easier to use one of the open end rubber hose adapters on the disconnected male fitting on the cooler line then to select the matching adapter.
4. Connect 12 inch adapter hoses to fitting adapters.
5. Connect 10 ft black and red hoses (right side of ATX-3 PLUS BOOST) to the 12 inch adapter hoses.

IMPORTANT

Attempt to pull hoses apart to ensure couplers are attached properly.

6. Connect red (positive) clamp on power cable to red (positive) terminal on vehicle battery. Connect the black (negative) clamp to a ground on vehicle frame. All lights on keypad should illuminate for 1 second and buzzer should pulse. If not, check connections and make sure REVERSE POLARITY light is not illuminated.

WARNING: Handle battery connection cable with extreme caution. Batteries generate explosive gases during normal operation. Working in the vicinity of a lead-acid or other automotive battery is dangerous. Wear eye protection. Never smoke or allow a spark or flame in the vicinity of the battery. Do not connect the black power clip to the negative post of the battery to avoid a spark.

7. Set the park brake and turn engine on, listen for the buzzer to sound once loudly and for the READY light on the keypad to stay illuminated. The ATX-3 PLUS BOOST pressure gauge on the control panel will indicate a positive pressure if the connection to the transmission is correct.

If buzzer does not sound and light does not illuminate **IMMEDIATELY TURN ENGINE OFF** and switch the black and red 10 ft hoses and repeat the above.

- A. For most Chrysler and Mitsubishi vehicles the transmission pump will be functioning when the vehicle is in "Neutral" instead of "Park". Perform the service in Neutral gear on these vehicles.
8. Press the COOLER MODE button. The light on the button will illuminate.
9. Once the ATX-3 PLUS BOOST is connected properly (READY light stays illuminated) the machine automatically goes into circulate mode. Check hoses for heat, if circulate is working correctly both hoses should be warm to the touch.
10. The ATX-3 PLUS BOOST pressure gauge will indicate the transmission operating pressure. Refer to the manufacturer's recommended pressure to determine if the transmission system is functioning correctly.

COOLER MODE FLUSH

1. Vehicle engine is running and the ATX-3 PLUS BOOST is connected as previously described, READY light is illuminated.
2. Slowly add Flush Solution as recommended by the supplier into the vehicle through the transmission system dip stick port.
3. The ATX-3 PLUS BOOST will now circulate the solution through the transmission system until a procedure is selected. The Flush Solution will be removed from the system during the exchange procedure.

DRAIN PAN

Note: If transmission filter is to be replaced, perform the following procedure before removing the transmission pan. If not, skip to the next procedure.

1. Vehicle engine is running and the ATX-3 PLUS BOOST is connected as previously described, READY light is illuminated.
2. Press the DRAIN PAN button on the keypad.
3. Buzzer will sound once and DRAIN PAN light will stay illuminated. If an error occurs the buzzer will sound three times and the ATX-3 PLUS BOOST will not proceed with the procedure, check all connections.
4. The vehicle transmission pump in conjunction with boost pump will empty contents of transmission system into the ATX-3 PLUS BOOST used fluid tank. Liquid level can be viewed through the Used Fluid Level Indicator on the left side of the ATX-3 PLUS BOOST.
5. When vehicle pan is emptied of transmission fluid the ATX-3 PLUS BOOST will automatically switch to the circulate mode, the buzzer will sound continuously and the PROCESS COMPLETE light will stay illuminated until the STOP button is pressed.
6. Turn the vehicle off IMMEDIATELY after ATX-3 PLUS BOOST buzzer sounds. The vehicle is now ready to have the transmission pan removed.
7. After the pan is replaced, refill the pan using the +1/2 Liter button (refer to the **+1/2 LITER** section). Check the transmission dip stick periodically while refilling to reach proper level.

Note: If the ATX will not add +1/2 liter, there may not be enough fluid remaining in the transmission to satisfy the minimum pressure requirement. To correct this situation, stop engine. Press Empty New Fluid and manually monitor the level of fluid in the new fluid tank. Press the Stop button after two liters have been added to the transmission. Restart vehicle and verify the Ready LED is illuminated. Check fluid level in the transmission. The +1/2 liter and -1/2 liter procedures can be used to adjust the level.

Caution: Do not let the engine run for more than one minute after the ATX-3 PLUS BOOST buzzer sounds. Letting the transmission run with an empty pan for an extended amount of time can cause serious damage to the transmission system.

COOLER MODE FLUID EXCHANGE (4,8,12,16,20 LITERS)

1. Vehicle engine is running and the ATX-3 PLUS BOOST is connected as previously described, READY light is illuminated.
2. Determine vehicle transmission fluid capacity from the vehicle operator or service manual.
3. Light on COOLER MODE button should be illuminated. Press the corresponding LITER button; always round up (for example if vehicle capacity is 6.5 LITER, an 8 LITER exchange would be selected).
4. The exchange of fluid can be monitored through ATX-3 PLUS BOOST Old-New Sight Bowls. These bowls display the new bright red fluid leaving ATX-3 PLUS BOOST and the dirty brown to black fluid coming from vehicle transmission system. The color of the used should become almost equal to the new as exchange ends. The liquid levels can be viewed through Level Indicators on either side of ATX-3 PLUS BOOST (left side for used, right side for new).
5. When exchange of transmission fluid is complete, ATX-3 PLUS BOOST will automatically switch to the bypass loop, the buzzer will sound continuously and PROCESS COMPLETE light will stay illuminated until STOP button is pressed.
6. Check transmission dip stick for level. Use +1/2, -1/2 LITER buttons as required to correct fluid level.

NOTE

Some transmission pumps may have a flow rate so low that the ATX will briefly pause (or even stop) during the exchange process. A series of two long beeps will indicate this condition. Accelerating the engine will usually overcome this situation and decrease the overall time required for the exchange process.

Servicing Vehicles with Transmission Thermostats

Common for Ford vehicles

With the vehicle engine running, the READY light will illuminate but the service will not proceed if the transmission fluid is cold.

The fluid inside the transmission must be heated to approximately 180°F. The most efficient way to do this is to put the vehicle in reverse. Setting the emergency brake, using a pedal depressor, or putting blocks behind the rear wheels can be done to help secure the vehicle. MAHLE recommends that the vehicle is not left unattended while in gear.

The service may start with very little or no flow. The service will commence, and take approximately 15 minutes to complete.

-1/2 LITER

1. Vehicle engine is running and the ATX-3 PLUS BOOST is connected as previously described, READY light is illuminated.
2. Check transmission dip stick. Press the -1/2 LITER button to lower the fluid level if the transmission system is overfilled.
3. When process is complete the buzzer will sound continuously and the PROCESS COMPLETE light will stay illuminated until the STOP button is pressed.
4. Check transmission dip stick for appropriate level.

+1/2 LITER

1. Vehicle engine is running and the ATX-3 PLUS BOOST is connected as previously described, READY light is illuminated.
2. Check transmission dip stick. Press the +1/2 LITER button to raise the fluid level if the transmission system is under filled.
3. When process is complete the buzzer will sound continuously and the PROCESS COMPLETE light will stay illuminated until the STOP button is pressed.
4. Check transmission dip stick for appropriate level.

DISCONNECTING FROM THE TRANSMISSION SYSTEM

- Caution -

Hoses, fitting adapters and the engine may be extremely hot. Use extreme caution when disconnecting.

1. Turn vehicle engine off. READY light should go off. Make sure READY light is **OFF** before proceeding.
2. Disconnect ATX-3 PLUS BOOST from the vehicle battery.
3. Disconnect 10 ft black and red hoses from the 12 inch adapter hoses.
4. Disconnect 12 inch adapter hoses from fitting adapters connected to the transmission system.
5. Disconnect fitting adapters from the transmission system connection points.
6. Reconnect cooler lines. Do not cross-thread cooler line fittings when reconnecting to the transmission system.
7. Start vehicle engine and check for leaks at cooler line connection points, tighten if necessary. Vehicle transmission service is complete once transmission system is leak free.

GOOD PRACTICE

Empty used fluid tank after every exchange procedure.

DIPSTICK MODE: CONNECTING TO THE TRANSMISSION SYSTEM

IMPORTANT

Check transmission fluid level according to manufacturer's instructions before connecting the ATX-3 PLUS BOOST.

Transmission must be up to operating temperature

Adjust fluid level if required

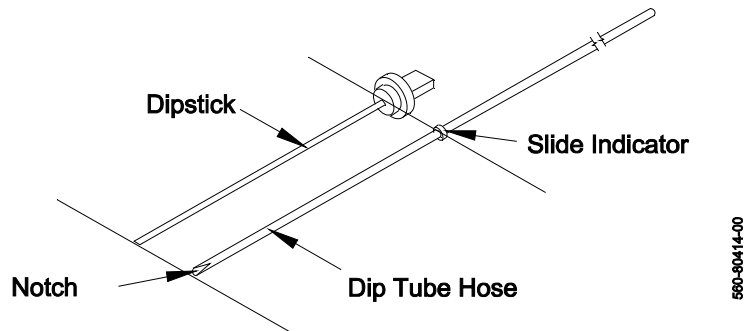

DO NOT USE SMALL DIP TUBE HOSE UNLESS ABSOLUTELY NECESSARY FOR SMALL DIPSTICK PORT

1. Remove transmission dipstick.
2. Hold notched end of Dip Tube Hose even with the end of the dipstick as shown above.
3. Position Slide Indicator so that Dip Tube Hose will insert one inch deeper into the transmission.

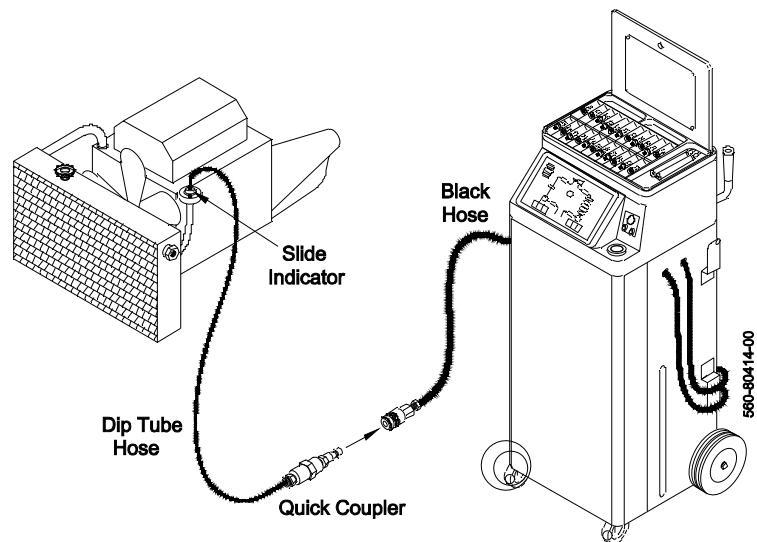

4. Insert notched end of Dip Tube Hose into transmission so the Slide Indicator is even with the top of the dipstick port as shown above.
5. Attach Quick Coupler to other end of Dip Tube Hose.
6. Insert Quick Coupler into fitting on end of black hose on left side of ATX-3 PLUS BOOST.
7. Connect red (positive) clamp on power cable to red (positive) terminal on vehicle battery. Connect the black (negative) clamp to a ground on vehicle frame. All lights on keypad should illuminate for one second and buzzer should pulse. If not, check connections and make sure REVERSE POLARITY light is not illuminated.

WARNING: Handle battery connection cable with extreme caution. Batteries generate explosive gases during normal operation. Working in the vicinity of a lead-acid or other automotive battery is dangerous. Wear eye protection. Never smoke or allow a spark or flame in the vicinity of the battery. Do not connect the black power clip to the negative post of the battery to avoid a spark.

8. Press the DIPSTICK MODE button. The light on the button will illuminate.

DRAIN PAN

Note: If transmission filter is to be replaced, perform the following procedure before removing the transmission pan. If not, skip to the next procedure.

1. Light on DIPSTICK MODE button should be illuminated. Press the DRAIN PAN button on the keypad.
2. Buzzer will sound once and DRAIN PAN light will illuminate. If an error occurs the buzzer will sound three times and the ATX-3 PLUS BOOST will not proceed with the procedure, check all connections.
3. The ATX-3 PLUS BOOST will withdraw used transmission fluid into the used fluid tank. The amount can be viewed on used LED readout and on Used Fluid Level Indicator on left side of ATX-3 PLUS BOOST.
4. When all possible fluid has been withdrawn, the buzzer will sound continuously.

DIPSTICK MODE FLUID EXCHANGE (4,8,12,16,20 LITER)

1. Determine vehicle transmission fluid capacity from the vehicle operator or service manual.
2. Light on DIPSTICK MODE button should be illuminated. Press the corresponding LITER button, always round up (for example if vehicle capacity is 6.5 liters, an 8 liter exchange would be selected).
3. If the ATX-3 PLUS BOOST is unable to remove any fluid from the pan within first 30 seconds FloErr (Flow Error) message will be displayed and process will be aborted. Check if dipstick tube is inserted properly, to appropriate depth (see Page 11). Another reason for this message is an insufficient amount of transmission fluid in the vehicle transmission pan.
4. The change of fluid can be monitored through the ATX-3 PLUS BOOST dip tube hose. This hose displays the new bright red fluid leaving the ATX-3 PLUS BOOST and the dirty brown to black fluid coming from the vehicle transmission system. The color of the used should become almost equal to the new as the exchange ends.
5. The process will start, removing and then replacing as much fluid as possible. The START ENGINE light will then illuminate.
6. Start the engine and then press the START ENGINE button. There will be 10 second delay after START ENGINE button is pressed to allow the new fluid to intermix with fluid in transmission system. After 10 seconds, the exchange will continue.
7. There is a 10 second pause after each refill.
8. If machine is unable to retrieve more than 0.4 of a quart from the pan while engine is running, the Flo Err (Flow Error) message will be displayed and process needs to be aborted. Stop the process and refill fluid to match required level.
9. When the exchange of transmission fluid is complete the buzzer will sound continuously and the PROCESS COMPLETE light will stay illuminated until the STOP button is pressed.
10. Remove Dip Tube Hose and check dipstick for level. If necessary, the Dip Tube Hose can be re-inserted and the +1/2, -1/2 LITER buttons pressed as required to correct fluid level.

Servicing Vehicles with Transmission Thermostats

Common for Ford vehicles

Dipstick Mode Service:

There is no need to heat the transmission fluid for a Dipstick Mode service. For Ford vehicles, adapter number 300 80126 00 is needed to complete the service.

-1/2 LITER

1. Vehicle engine is running and the ATX-3 PLUS BOOST is connected as previously described, READY light is illuminated.
2. Light on DIPSTICK MODE button should be illuminated. Press the -1/2 LITER button to lower the fluid level if the transmission system is overfilled.
3. When process is complete the buzzer will sound continuously and the PROCESS COMPLETE light will stay illuminated until the STOP button is pressed.
4. Remove dip tube hose from transmission.
5. Insert transmission dipstick and check for appropriate level.

+1/2 LITER

1. Vehicle engine is running and the ATX-3 PLUS BOOST is connected as previously described, READY light is illuminated.
2. Light on DIPSTICK MODE button should be illuminated. Press the +1/2 LITER button to raise the fluid level if the transmission system is under filled.
3. When process is complete the buzzer will sound continuously and the PROCESS COMPLETE light will stay illuminated until the STOP button is pressed.
4. Remove dip tube hose from transmission.
5. Insert transmission dipstick and check for appropriate level.

EMPTY USED (Common for both modes)

1. Connect red (positive) clamp on ATX-3 PLUS BOOST power cable to red (positive) terminal on vehicle battery. Connect the black (negative) clamp to a ground on vehicle frame, vehicle engine is turned OFF. The ATX-3 PLUS BOOST **10 ft black and red hoses must be disconnected from transmission.** READY light is off.
2. Place end of **8 ft black hose (left side of ATX-3 PLUS BOOST)** in bulk used fluid container. Attach short black adapter hose with open end to coupler on end of 8ft black hose.
3. Press the EMPTY USED button on the keypad.
4. Buzzer will sound and used transmission fluid will empty from used tank inside ATX-3 PLUS BOOST to the bulk container. Level can be viewed through Level Indicator on left side of the ATX-3 PLUS BOOST.
5. Procedure will run until used tank is completely emptied or the STOP button is pressed. If process is allowed to run until completion (30 seconds after used fluid tank is empty), the buzzer will sound continuously and the PROCESS COMPLETE light will stay illuminated until the STOP button is pressed.
6. **Remove short black adapter hose** on 8ft black hose and remove it from bulk used fluid container.

EMPTY NEW (Common for both modes)

1. Connect red (positive) clamp on ATX-3 PLUS BOOST power cable to red (positive) terminal on vehicle battery. Connect the black (negative) clamp to a ground on vehicle frame. Vehicle engine is turned OFF. **The 10 ft black and red hoses must be disconnected from the transmission.** READY light is off.
2. Couple any fitting adapter to the end of the **10 ft red hose (right side of ATX-3 PLUS BOOST).** Place end of hose in bulk storage container for later use.
3. Press the EMPTY NEW button on the keypad.
4. Buzzer will sound and new transmission fluid will empty from new tank inside the ATX-3 PLUS BOOST to the bulk container. Level can be viewed through Level Indicator on right side of the ATX-3 PLUS BOOST.
5. Procedure will run until new tank is completely emptied or the STOP button is pressed. If process is allowed to run until completion (30 seconds after new fluid tank is empty), the buzzer will sound continuously and the PROCESS COMPLETE light will stay illuminated until the STOP button is pressed.
6. Disconnect fitting adapter from end of the 10 ft red hose.

MAINTENANCE

The ATX-3 PLUS BOOST will provide many years of reliable service if properly maintained. The following checklist will ensure that the ATX-3 PLUS BOOST will run at peak efficiency and present an image to your customers that your shop performs high tech transmission services.

1. Use tool tray for storage of tools and adapters only.
2. Keep the exterior surface clean. Use a mild all-purpose cleaner to wipe transmission fluid and dirt off the cabinet.
3. Do not allow the unit to sit outside in direct sunlight or inclement weather. Excessive exposure to sunlight or moisture will cause serious damage and will void the warranty.
4. The ATX-3 PLUS BOOST is not intended for mobile use where the unit is transported to customer sites. Excessive vibration will shorten component life, affect accuracy of performance and void the warranty. If the ATX-3 PLUS BOOST needs to be transported by vehicle, remove all fluid, in both the new and used tanks, prior to transport.
5. Be gentle when moving the ATX-3 PLUS BOOST around the shop. Tip the unit and ease the front casters over any obstacles such as door jams, air hoses and floor irregularities.
6. Periodically check all internal (by lifting out the tool tray) and external hoses for leaks or excessive wear. Any weak hoses should be replaced immediately to avoid possible injury.
7. Check the four filter screens (Item 4 and 5 on Page 18) often to avoid any blockage that may occur. Clean out debris or replace the filter screen if necessary.

Calibration - A Good Practice

The ATX-3 PLUS BOOST is the most accurate of all transmission fluid exchange equipment due to the advanced load cell technology designed into the unit.

Most operating problems are usually fixed by performing a simple calibration procedure.

A good practice is to periodically calibrate the ATX-3 PLUS BOOST to ensure optimum performance.

The following pages describe the reasons for calibration and the actual calibration procedure.

TROUBLESHOOTING

If in Dipstick Mode and the READY light is on and the ATX-3 PLUS BOOST is unresponsive to a button being pressed to initiate a process, do the following:

1. Press COOLER MODE.
2. Press DRAIN PAN.
3. Press STOP after pressure on gauge reaches 0 PSI or after 3-4 seconds.

The READY light should go off. If not, repeat above steps a second time.

If the new fluid tank is full and Add New Fluid light is flashing while selecting an exchange service, lower the volume of new transmission fluid to 25 liters, using EMPTY NEW FLUID feature.

ATX-3 PLUS BOOST CALIBRATION

The ATX-3 PLUS BOOST is a high-tech, electronically controlled machine for exchanging transmission fluid. The ATX-3 PLUS BOOST is connected in series with the transmission fluid flow at the cooler hose. The vehicle transmission pump, aided by the units' boost pump, then pumps used fluid into the ATX-3 PLUS BOOST used fluid tank and the ATX-3 PLUS BOOST pumps new fluid to the transmission from the new fluid tank in the ATX-3 PLUS BOOST. Transmission pumps vary in their flow rate from vehicle manufacturer to manufacturer. This requires that the ATX-3 PLUS BOOST monitor the old fluid coming from the transmission and then pump new fluid back to the transmission at the same rate.

The used and new fluid tanks in the ATX-3 PLUS BOOST each sit on a weight scale (load cell). The increasing weight of used fluid is monitored by the electronic controller which in turn controls the speed of the ATX-3 PLUS BOOST pump which is pumping new fluid to the transmission.

The function of the ATX-3 PLUS BOOST is to pump new fluid into the transmission as the transmission, aided by the ATX-3 boost pump, pumps out used fluid at a rate that will keep the transmission fluid level consistent. Not too much and not too little. This occurs with the design of the ATX-3 PLUS BOOST in a near-perfect world. So, what is the real world?

Real world conditions must be considered:

- 1) Not all new transmission fluids weigh exactly the same. They are very close.
- 2) Old transmission fluids can have different weights. Very old fluid can have a lot of solids suspended in the fluid and be very heavy.
- 3) Not all transmissions pump or control the flow of fluid in the same way. Some are very slow. Others cycle the flow of fluid off and on to the cooling lines dependent on the temperature of the fluid. Both of these examples might make the technician think the ATX-3 PLUS BOOST is not operating correctly because it takes so long to do the exchange. The procedure can be speeded up by accelerating the engine to 2000 RPM during the exchange.

These real world inconsistencies are expected and therefore the add or remove ½ liter feature was built into the ATX-3 PLUS BOOST

Slots are provided on the sides of the ATX-3 PLUS BOOST so that the technician can see the fluid levels in the tanks. The scales next to the slots **approximately** indicate the number of liters in the tanks. The only purpose of these slots is to give the technician an idea of when the used fluid tank might need to be emptied or how many bottles of new fluid to bring from the supply room to fill the new fluid tank.

Calibration of BOTH load cells is required when:

1. **REMOVE USED FLUID** flashes and three beeps are heard when trying to select amount of fluid to be exchanged. The level of fluid in the used fluid tank is observed to be such that the tank is not full or would not fill to capacity during an exchange procedure. For example, **8 LITER** is pressed and there is obviously room in the used fluid tank to accept 10 or more liters.
2. **ADD NEW FLUID** flashes and three beeps are heard when trying to select amount of fluid to be exchanged. For example, **8 LITER** is pressed and more than 10 liters of fluid can be seen in the new fluid tank.
3. **REMOVE USED FLUID** flashes continuously.
4. **ADD NEW FLUID** flashes continuously.
5. The control board is replaced for any reason.

CALIBRATION OF LOAD CELLS

The ATX-3 PLUS BOOST has two tanks, each mounted on a load cell. One tank is for new fluid and one is for used fluid. Each tank is **permanently bolted** to a load cell platform which cannot be removed from the unit. The calibration procedure below must be performed for **both** load cells.

Never calibrate only one load cell as an imbalance may occur and the ATX-3 PLUS BOOST will not operate correctly.

1. Remove the rear panel.
2. Place end of **8 ft black hose (left side of ATX-3 PLUS BOOST)** in bulk used fluid container. Place any adapter onto coupler on end of hose.
3. Press and hold **4 LITER** and **20 LITER** buttons until a long beep is heard.
4. Select which load cell is to be calibrated.
 - a) Press **-1/2 LITER** to calibrate the used fluid load cell. **REMOVE USED FLUID** will be flashing throughout the remaining steps. A short beep will be heard.
 - b) Press **+1/2 LITER** to calibrate the new fluid load cell. **ADD NEW FLUID** will be flashing throughout the remaining steps. A short beep will be heard.

The pump will run and empty the contents of the selected tank through the 8 ft black hose into the collection container.

5. Press the **STOP** button when fluid is no longer leaving the machine through the black hose and the selected tank is empty. The pump will stop running. The **4 LITER** will be flashing. A short beep will be heard. Check that the tank is empty.
6. Press the **STOP** button again. The **12 LITER** will be flashing. A short beep will be heard. This programs the minimum weight.
7. Place two 5 kg or one 10 kg calibration weight on the top of the selected tank. (10 kg = 22 lbs)
8. Press the **STOP** button. The **12 LITER** will be illuminated. A short beep will be heard. This programs the maximum weight.
9. Remove calibration weight(s) and replace rear cover.
10. Press the **STOP** button again. A short beep will be heard. The machine returns to regular operating mode.

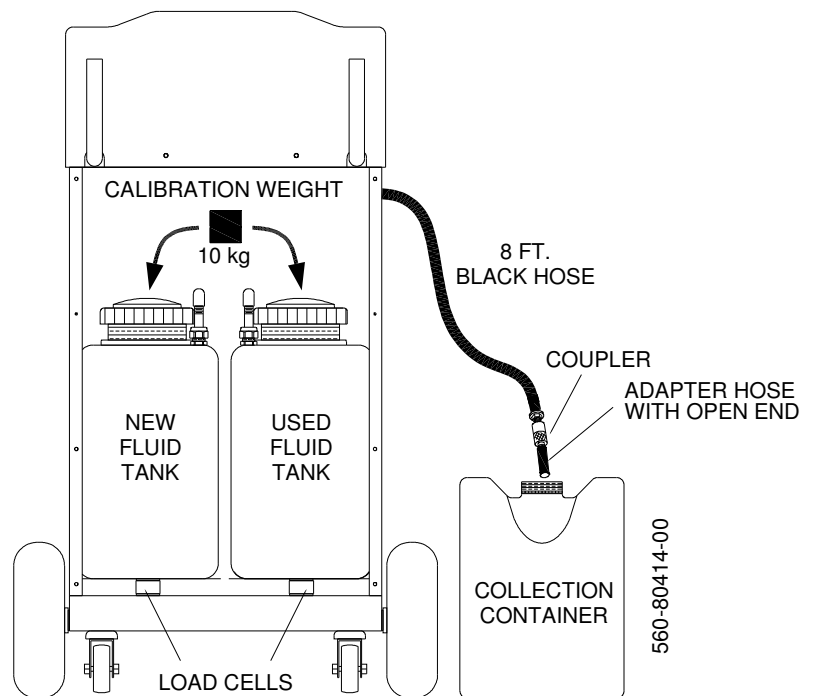

PARTS IDENTIFICATION ATX-3 PLUS BOOST

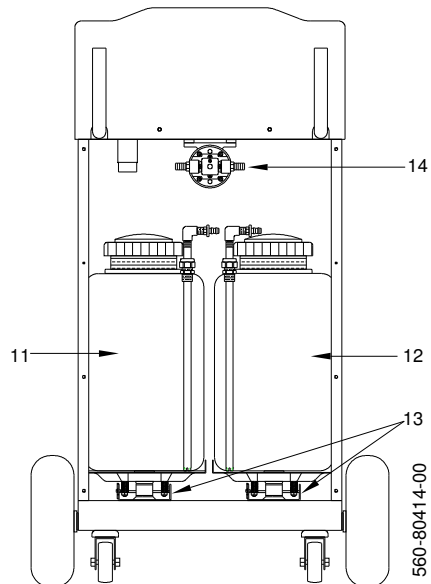
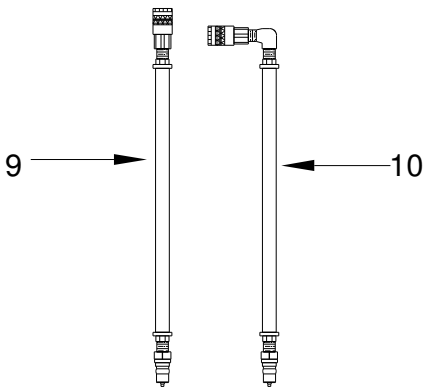
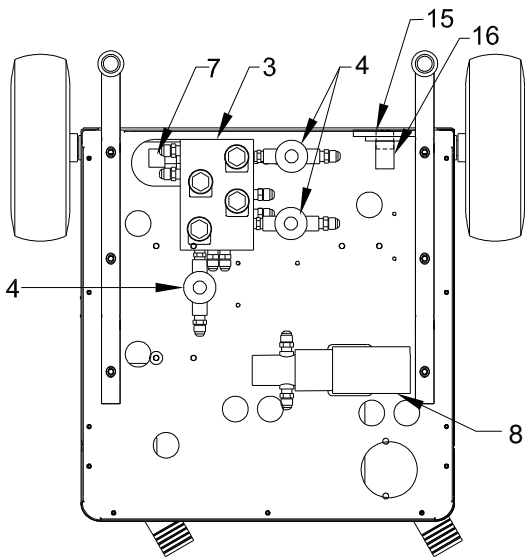
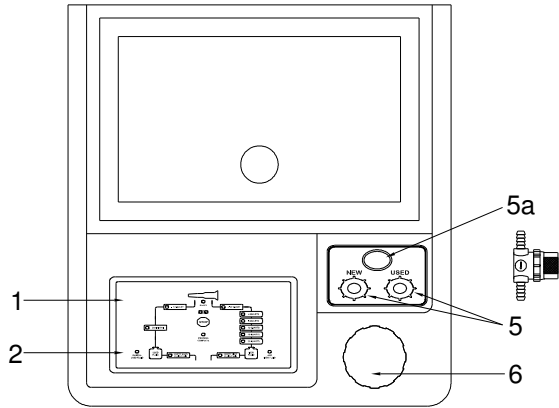

	Part No.	Description
1	024-80149-00	Keypad Overlay
2	024-80150-00	Circuit Board (12VDC)
3	300-80107-00	Manifold Assembly
4	026-80250-00	Sight Glass 1/4" FPT w/screen
	026-80248-00	Filter Mesh Cylinder 80 SS
5	026-80247-00	Glass Sight 3/8" Barb Plastic w/Bowl
	026-80248-00	Filter Mesh Cylinder 80 SS
5a	300-80104-00	Pressure Gauge Assembly
6	021-80164-00	Deck Fill Assembly ATX
7	022-80111-00	Pressure Switch 4-6 psig SPST
8	300-80033-00	Pump Gear .33 GPM 12VDC
9	300-80014-00	Hose Assembly Straight
10	300-80015-00	Hose Assembly 90 Degree
11	300-80038-00	New Fluid Tank Assembly
12	300-80040-00	Used Fluid Tank Assembly
13	031-80002-00	Load Cell 35 Kg
14	300-80106-00	Pump Assembly Diaphragm
15	024-80091-00	Relay 40 amp SPDT 12vdc coil
16	024-80115-00	Relay 4PDT 12vdc Coil Plugin

FLOW DIAGRAM

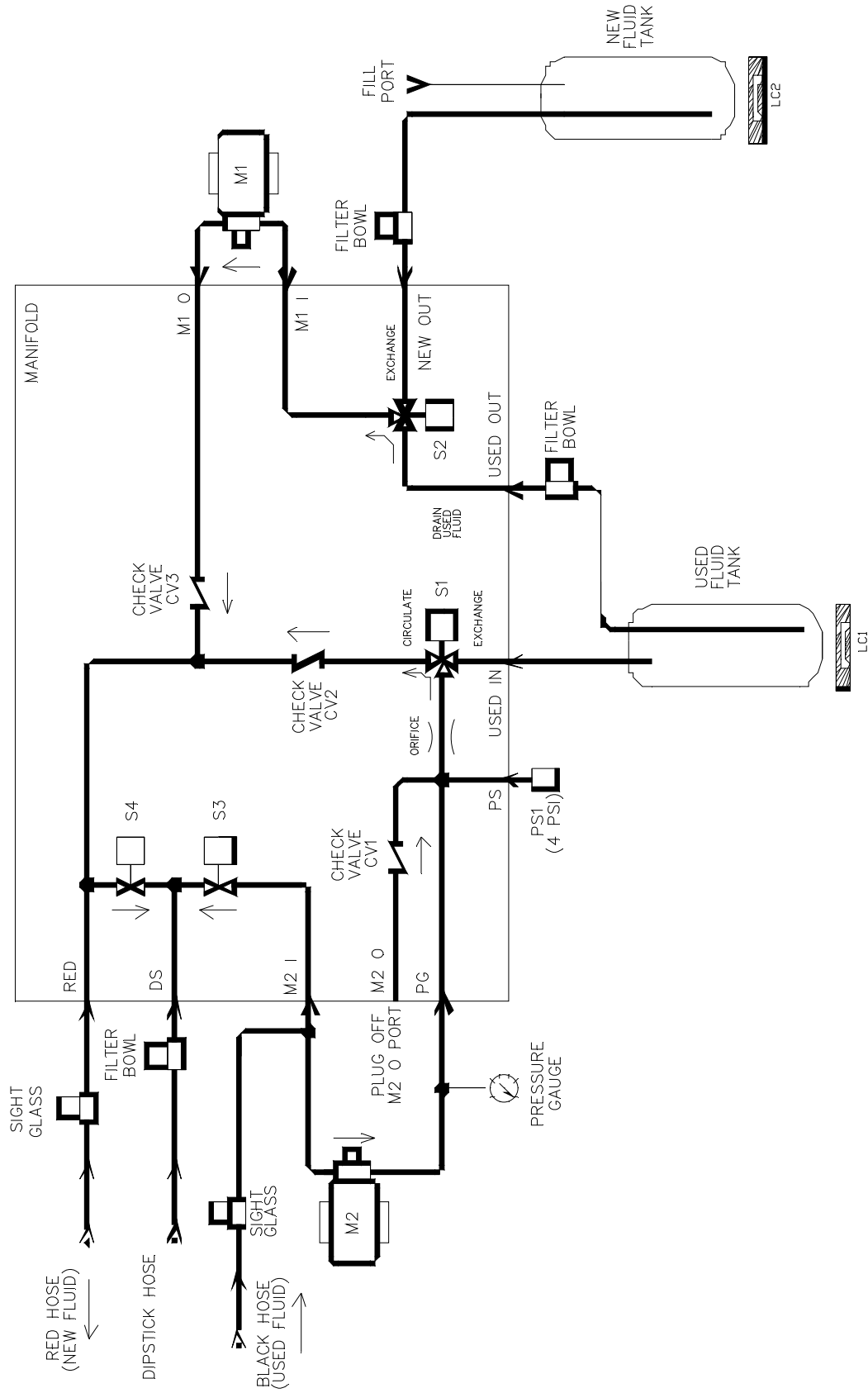

DATE: 03-30-10

570-80417-00 (REV B)

ATX-3 MACHINE FLOW WITH BOOST

WIRING DIAGRAM

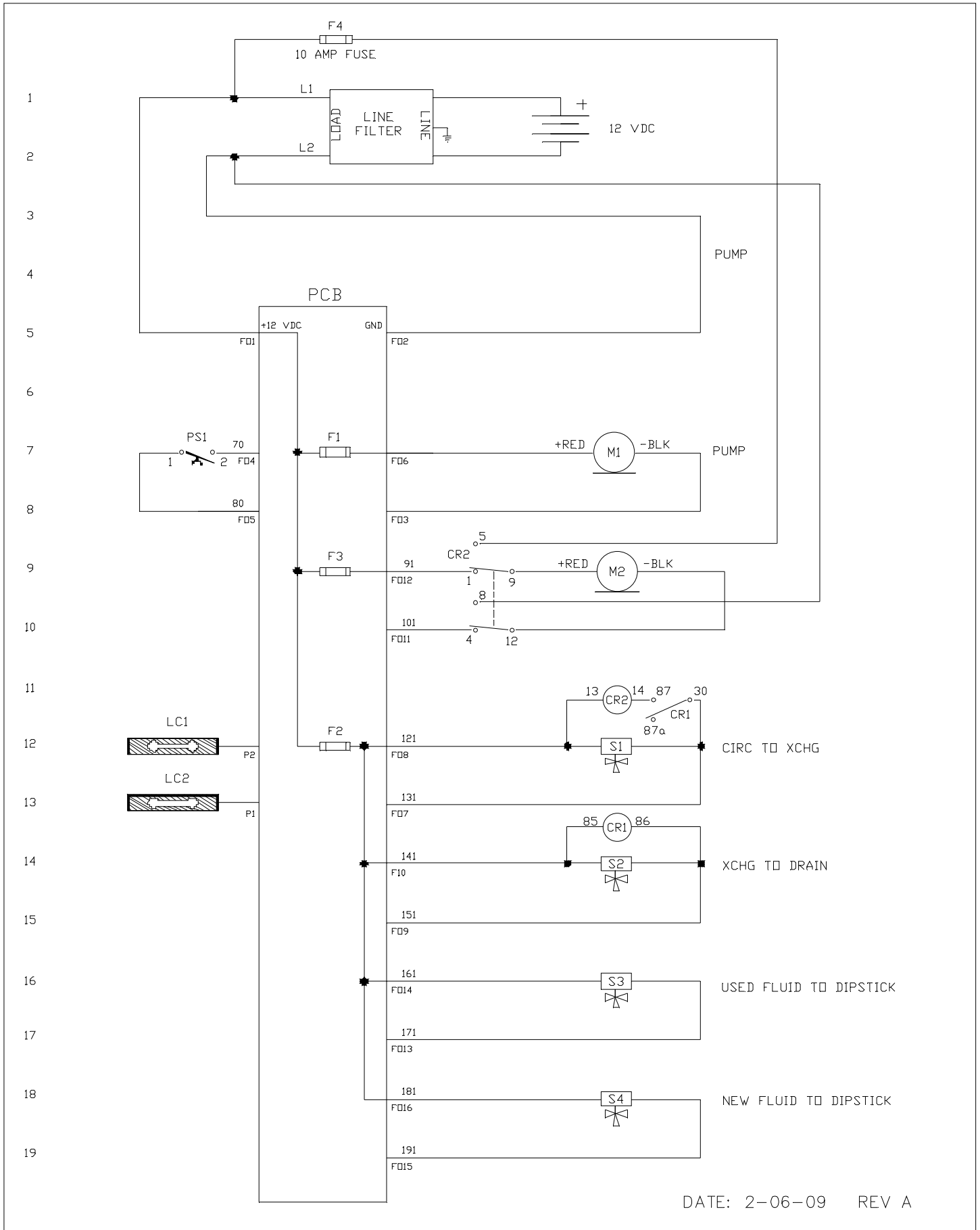

EC Declaration of Conformity for Machinery

Directive 98/37/EC



MAHLE Aftermarket Inc., Service Solutions

10 Innovation Drive
York, Pennsylvania 17402 USA
Phone: 717-840-0678

Herewith declares that:

-ATX-3 Transmission Fluid Exchange Machine

-is in conformity with the provisions of the Machinery Directive (directive 98/37/EC) and with the national implementing legislation

-is in conformity with the provisions of the following other EC directives:

Electromagnetic Compatibility (EMC) Directive 89/336/EEC

Electromagnetic Emissions EN 61000-6-4: 2001

Electromagnetic Immunity EN 61000-6-2: 1999

The ATX-3 was tested and certified to the EMC Directive by:

TÜV America Inc.
1775 Old Highway 8 NW Ste. #104
New Brighton, MN 55112
Phone: 651-638-0262

Eric I. Shultz



Vice President - Technology

Dated: February 20, 2013



NOTES

NOTES