

# OPERATION & MAINTENANCE MANUAL

# RHS780

Refrigerant Handling Station



**MAHLE Aftermarket Inc., RTI Division**

10 Innovation Drive

P.O. Box 3099

York, Pennsylvania USA 17402

717-840-0678 (Ext. 259)

Web: [www.rtitech.com](http://www.rtitech.com)

E-mail: [tech@rtitech.com](mailto:tech@rtitech.com)

035-81123-00



# TABLE OF CONTENTS

## RHS780

Before Using the RHS780 .....	3
Safety Precautions .....	3
Using the RHS780 .....	4
Setup .....	5
Filling the Charge Cylinder .....	6
Recover/Recycle .....	7
Draining Recovered Oil .....	8
Deep Vacuum .....	9
Charging .....	10
Automatic .....	11
Accessing Stored Data .....	12
Setting Over Charge Amount .....	14
Scheduled Maintenance & Filter Maintenance .....	15
Parts Identification .....	16
Solenoid, Pressure Switch & Contactor Identification . . .	18

## CONGRATULATIONS

**You have purchased one of the finest Recovery, Recycling and Charging Machines available! Fill out and return the Warranty Card within 90 days to activate warranty and free lifetime technical support.**

## BEFORE USING THE RHS780

Check for any shipping damage. Place a claim with carrier if damage is discovered. **DO NOT USE A DAMAGED UNIT.**

**Complete and return the Warranty Card to activate technical support service and warranty coverage.**

These general instructions describe normal operation and maintenance situations encountered with the RHS780. Failure to read and comply with these instructions or any one of the limitations noted herein can result in serious injury and/or property damage.

A few minutes spent reading these instructions can make an operator aware of dangerous practices to avoid and precautions to take for his own safety and the safety of others. The instructions should not be interpreted to anticipate every possible contingency.

The RHS780 should not be operated or serviced by any person who has not read all the contents of this manual.

It is the responsibility of the owner/user to operate the RHS780 in accordance with all specifications and laws which may apply.

A regular schedule of inspection of the RHS780 should be established and records maintained with special attention given to Hoses, Vacuum Pump Oil Level, and Filters.

## SAFETY PRECAUTIONS

Recover, Recycle, and Charge only the refrigerant for which the machine is configured.

Wear safety glasses and protective gloves. Refrigerant has a very low boiling point and can cause frostbite.

Follow the RHS780 operating procedures sequentially to avoid prematurely disconnecting hoses or opening valves which may release refrigerant to the atmosphere.

Do not expose the RHS780 to moisture or operate in wet areas.

Use the RHS780 in locations with mechanical ventilation that provides at least four air changes per hour.

Hoses used with the RHS780 must have shutoff devices within 12 inches (30 centimeters) of the connection point to the A/C System to minimize the introduction of Non-Condensable Gas (Air) into the RHS780 and the release of refrigerant when being disconnected.

Disconnect power before performing any maintenance or service on the RHS780.

Connect the RHS780 to a properly grounded receptacle. Do not over load the circuit.

Avoid using an extension cord with the RHS780. If necessary use a good condition three wire, grounded, #14 AWG (2.0 mm<sup>2</sup>) or larger extension cord of the shortest possible length.

Do not connect the RHS780 to the liquid side of any A/C System with a capacity greater than 4 lbs (1.8 Kg.) Refrigerant in A/C Systems having larger capacities must be recovered from the vapor side only.

Never connect the Red or Blue Hose on the rear of the RHS780 to the Liquid Port of a Cylinder of Refrigerant to fill the Charge Cylinder. Doing so may cause the Compressor to fail and void the warranty.

Avoid breathing refrigerant or lubricant vapor or mist. Exposure may irritate eyes, nose and throat. If accidental system discharge occurs, ventilate work area before continuing.

Additional health and safety information may be obtained from refrigerant and lubricant manufacturers.

## Special Considerations with R134a

R134a has been shown to be nonflammable at ambient temperature and atmospheric pressure. However, tests under controlled conditions have indicated that at pressures above atmospheric and with air concentrations greater than 60 percent by volume, R134a can form combustible mixtures.

While it is recognized that an ignition source is also required for combustion to occur, the presence of combustible mixtures is a potentially dangerous situation and should be avoided.

Under no circumstances should any equipment be pressure tested or leak tested with Air and R134a mixtures. Do not use compressed air (shop air) for leak detection in R134a systems.

# USING THE RHS780

Note: The purpose of this discussion is to familiarize the user with the features and functions of the RHS780 Refrigerant Handling Station. The procedures discussed in this manual assume that the RHS780 has been set up in accordance with the figures which are referred to and that the RHS780 has been connected to the proper power supply. This manual does not illustrate correct A/C service but rather how to correctly use the RHS780.

The RHS780 is microprocessor controlled with a menu driven user interface. All of the functions of the RHS780 are accessed by pressing a few simple key strokes and following the prompts. The on board Charging Cylinder is attached to a strain gauge measuring device and the weight is electronically displayed.

The RHS780 has a Fill Cylinder feature that allows refrigerant to be loaded directly into the Charging Cylinder without going through the normal Recover/Recycle mode. When selected, this feature allows the RHS780 Charging Cylinder to be refilled in just a few minutes at which point it will automatically stop at approximately 35 lbs (16 Kg.)

The RHS780 Recovers and Recycles simultaneously in a true “single pass” through the filters and stores the refrigerant in the Charging Cylinder where it is immediately available for use. This process automatically stops at 39.5 lbs (18 Kg) or when a 15”Hg (-0.5 Bar) vacuum is sensed. The RHS780 will wait for a minimum factory default of two minutes for “out gassing” and cold refrigerant to raise the pressure back up to 3 psig (0.2 Bar) which would cause the Recover/Recycle process to start again and reset this two minute Recycle Hold Timer before displaying that the process is complete. The Recycle Hold Timer can be changed every time a Recover/Recycle procedure is run. Longer times should be selected on colder days or on A/C Systems with large liquid capacities. Increasing this value may increase total time to Recover/Recycle while decreasing the time may result in an incomplete Recovery of the A/C System. Refer to the chart below for guidelines on setting the Recycle Hold Timer. The value entered is stored in the memory of the RHS780 and becomes the “default” value each time it is set. Non-Condensable Gases are vented automatically during Recovery/Recycle. The Amount of refrigerant Recycled is displayed at the end of the procedure. This value is added to the Total amount Recycled and stored in the memory of the RHS780 (see Accessing Stored Data on Page 12.)

Temperature	< 50F (10C)	50F (10C) to 80F (26.5C)	> 80F (26.5C)
Recycle Hold Time	10 min	5 min	2 min

An integrated 7 CFM rotary vane style Deep Vacuum Pump draws on both the High and Low Hoses, ensuring complete evacuation of the A/C System. The amount of time that the Vacuum Pump has been programmed to run will “count down” on the display. The value entered is stored in the memory of the RHS780 and becomes the “default” value each time it is set. The Low Pressure Gauge can be used to monitor a rise in A/C System pressure. When programmed to do so, the RHS780 will pause and start a “count up” timer indicating how long the Vacuum Pump has been off, thus allowing the operator to determine if a vacuum leak is present based on increasing pressure over time. A rapid rise in pressure indicates the presence of a large leak that should be repaired. A slow rise in pressure may simply indicate that a longer Recycle Hold Timer or Vacuum Time value should have been entered. A relatively constant vacuum reading over a long period of time (less than 2 InHg [0.07 Bar] rise over ten minutes) is the most accurate way to check for vacuum leaks. The RHS780 can also be programmed to pause to allow oil to be added, and to the A/C System after vacuuming and prior to Charging.

Charging is done via the on board Charging Cylinder. The A/C Capacity is entered via the Keypad. The value entered is stored in the memory of the RHS780 and becomes the “default” value each time it is set. The RHS780 can dispense liquid refrigerant through either the High or Low Side Hose by changing the position of a selector switch. As refrigerant leaves the RHS780, the display will show an increasing weight to the programmed charge amount plus a factory set 0.03 Kg (one ounce) Over Charge Amount necessary for compensation of refrigerant loss in the hoses. This Over Charge Amount can be changed to accommodate different operating conditions (see Setting Over Charge Amount on Page 13.) An integrated Heater automatically engages whenever Charging occurs. The Amount of refrigerant Charged is added to the Total amount Charged and stored in the memory of the RHS780 (see Accessing Stored Data on Page 12.)

The RHS780 can be programmed to perform the Recover/Recycle, Deep Vacuum and Charge in a completely Automatic mode. The RHS780 will always go through the Recover/Recycle procedure, but will go immediately to the Recycle Hold Timer if the A/C System is empty. The following matrix outlines the most commonly used options that can be programmed to occur after the Recycle Hold Timer “times out”:

Recover/Recycle	X	X	X	X	X	X	X	X
Deep Vacuum			X	X	X	X	X	X
Vacuum Leak					X	X		X
Add Oil							X	X
Charging		X		X		X	X	X

# SETUP

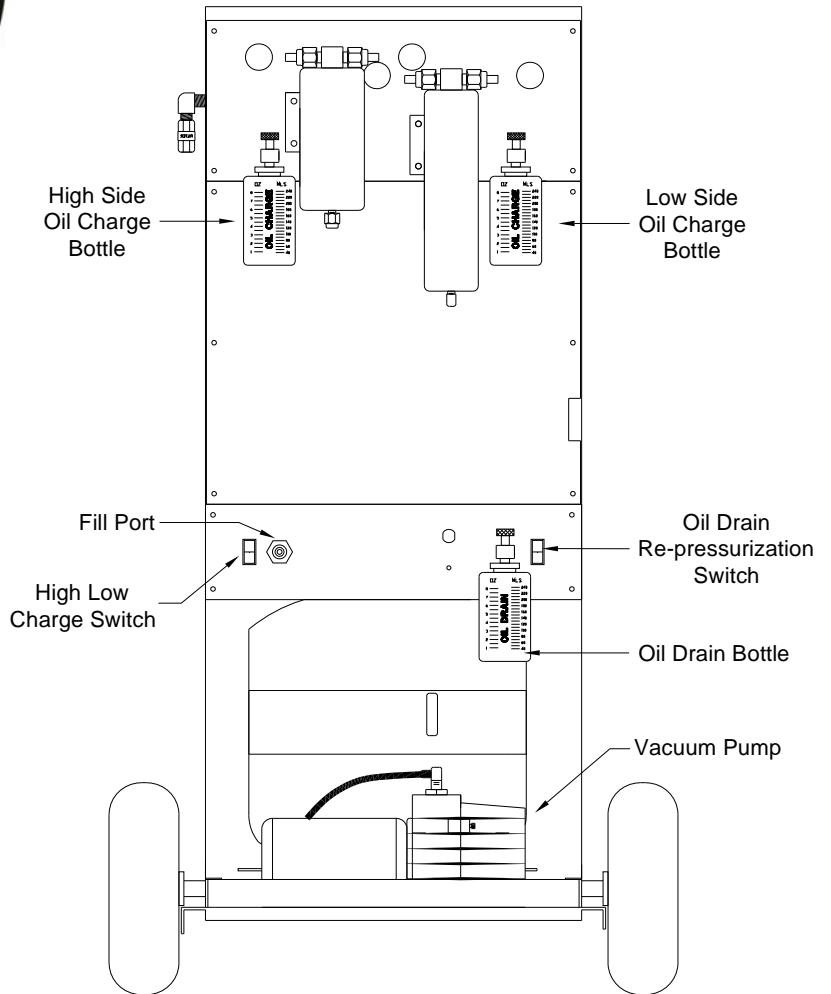
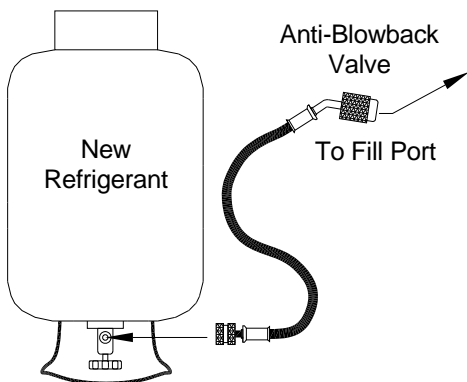

```
WEIGHT = XX.X LB
AUTOMATIC? ←
```

▲▲▲▲

```
WEIGHT = XX.X LB
FILL CYLINDER? ←
```

ENTER

```
CHECK HOSES
START? ←
```

ENTER

```
WEIGHT = XX.X LB
COMPRESSOR ON
```

```
FILL COMPLETE
FILLED = XX.X LB ←
```

ENTER

\*

```
HIGH PRESSURE
SEE MANUAL
```

\*\*

```
CYLINDER FULL
GO TO CHARGE ←
```

## FILLING THE CHARGE CYLINDER

**Note:** For large capacity or multiple A/C Systems where recharge will NOT be done between successive recoveries, it may be desirable to skip this procedure.

1. Setup the RHS780 as shown on Page 4 and then turn the Main Power Switch ON.

**Note:** The RHS780 uses 37 lbs (17 Kg) of refrigerant when Filling the first time. If the Refrigerant Cylinder is emptied the RHS780 will appear to stop filling (the Weight will stop rising) and will stay in this condition until the RESET key is pressed.

2. Using the Keypad, press the "Up Arrow" key four times to display "WEIGHT= XX.X LB" "FILL CYLINDER? ←" and press the ENTER key. The Display will read "CHECK HOSES" "START? ←".

3. Open the **LIQUID** Valve on the Refrigerant Cylinder connected to the Fill Port on the rear of the RHS780 with the Yellow Hose.

4. Press the ENTER key when ready to start filling the RHS780.

The Display will read "WEIGHT=XX.X LB" "COMPRESSOR ON". When the level is approximately 35 lbs (16 kg) the RHS780 will turn OFF, the Display will read "FILL COMPLETE" "FILLED= XX.X LB ←" (the amount of refrigerant removed from the cylinder) and the Attention Light will turn ON. Close the Liquid Valve on the Refrigerant Cylinder.

**Note:** Press the RESET button on the Keypad to stop the Fill Cylinder procedure at any time.

5. Press the ENTER key to return to the Main Menu.

This procedure may be slow or fail to work if the internal charge cylinder pressure is higher than the pressure in the cylinder of new refrigerant. Check and purge air if necessary (See Page 7).

Also, try putting a heat belt on the new refrigerant cylinder. or put the cylinder in a container of warm water.

\* While filling the Charging Cylinder, this screen will display periodically concurrent with the Attention Light turning ON. This is normal and nothing to be concerned about. The screen should revert to normal after a few seconds.

\*\* This screen will display when the Charging Cylinder fills to capacity, approximately 39.5 lbs (18 Kg). If this occurs, the Weight can be lowered using the Charging procedure on Page 9 before the RHS780 can be used to recover more refrigerant. Press the ENTER key to return to the Main Menu.

**Note:** The RHS780 Charging Cylinder can also be filled from the GAS or VAPOR side of a cylinder by following the Recover/Recycle procedure on Page 6.

**Note:** The RHS780 will use 1.1 Lb (0.5 Kg) more refrigerant than the displayed value the very first time it is used or after performing a Calibration Procedure in order to prime the internal components.

**Note:** The Yellow Hose can be removed from the Fill Port and connected to either the Blue {Low side} or Red {High Side} Hose connection port on the side of the RHS780 to allow recovering the refrigerant left over in the Yellow Hose using the Recover/Recycle procedure on Page 6.

WEIGHT = XX.X LB  
AUTOMATIC? ←

▲

WEIGHT = XX.X LB  
RECYCLE? ←

ENTER

RECYCLE HOLD  
TIME XX MIN ←

▲▶ ENTER

CHECK HOSES  
START? ←

ENTER

WEIGHT = XX.X LB  
COMPRESSOR ON

WEIGHT = XX.X LB  
COMPRESSOR OFF

AMOUNT RECYCLED =  
XX.X LB ←

ENTER

DRAIN RECOVERED  
OIL NOW! ←

ENTER

\*

HIGH PRESSURE  
SEE MANUAL

\*\*

CYLINDER FULL  
GO TO CHARGE ←

## RECOVER/RECYCLE

1. Setup the RHS780 as shown on Page 4 and then turn the Main Power Switch ON.
2. Attach the Red and Blue Hoses to the A/C System per the vehicle manufacturer's instructions, open the Red and Blue Hose Valves.
3. Using the Keypad, press the "Up Arrow" key one time to display "WEIGHT= XX.X LB" "RECYCLE? ←" and press the ENTER key. The Display will read "RECYCLE HOLD" "TIME XX MIN ←".

The Recycle Hold Time is the amount of time that the RHS780 waits for "out-gassing" or for the pressure in the A/C System being recovered to rise enough to automatically restart the recovery process. The minimum value is two minutes. The value entered is stored in memory and comes up as the default value the next time the procedure is used.

4. Press the "Up Arrow" key to change the value of the field. Press the "Right Arrow" key to change to a different field. Press the ENTER key to accept the value. The Display will then read "CHECK HOSES" "START? ←".
5. Press the ENTER key to start recovering and recycling with the RHS780.

The Display will read the "WEIGHT= XX.X LB" "COMPRESSOR ON". The RHS780 will recover and recycle refrigerant from the A/C System and automatically cycle OFF when a vacuum is sensed. This vacuum level can be seen on the Low Pressure Gauge. The Display will read "WEIGHT= XX.X LB" "COMPRESSOR OFF"

A small quantity of refrigerant will probably remain in the A/C System as observed by an increasing pressure on the Low Pressure Gauge. The RHS780 will automatically cycle ON to continue recovering refrigerant if pressure rises to a preset level. This automatic cycling will repeat resetting the Recycle Hold Timer each time. When the RHS780 remains OFF for the duration of the Recycle Hold Timer value entered in Step 4 the Display will read "AMOUNT RECYCLED=" "XX.X LB ←" from the A/C System and the Attention Light will turn ON.

6. Close the Red and Blue Hose Valves and disconnect the hoses from the A/C System.
7. Press the ENTER key. The Display will read "DRAIN RECOVERED OIL NOW!". Drain any recovered oil using the Drain Recovered Oil procedure on Page 7.
8. Press the ENTER key to return to the Main Menu.

\* This screen will display if there is an internal fault. Please contact RTI Technical Support. Turn the RHS780 Main Power Switch OFF.

\*\* This screen will display when the Charging Cylinder fills to capacity, approximately 39.5 lbs (18 Kg.) If this occurs, the Weight can be lowered using the Charging procedure on Page 9 before the RHS780 can be used to recover more refrigerant. Press the ENTER key to return to the Main Menu.



## DRAINING RECOVERED OIL

Oil is separated from the recovered refrigerant and **MUST** be removed following **EACH** Recover/Recycle procedure to determine the amount (if any) necessary to add into the A/C System as follows:

**Note: The RHS780 must be connected to power source. Draining Recovered Oil may be done while the RHS780 Vacuum Pump is ON.**

1. Setup the RHS780 as shown on Page 4 and press and hold the Oil Drain Re-pressurization Switch for 5 seconds and then release it.
2. **Slowly** open the valve on Oil Drain Bottle to drain any oil which may have been removed from the A/C System.

Unless the A/C System had previously been overfilled, the RHS780 will typically not remove enough oil to make replenishment necessary.

3. Close the valve on the Oil Drain Bottle.
4. Press and hold the Oil Drain Re-pressurization Switch for 5 seconds. This permits any residual Non-Condensable Gas to be re-circulated for reprocessing during the next recycle procedure.

### WARNING

**Failure to perform the Drain Oil procedure after every recycle procedure will cause the RHS780 to eventually fail.**

**Repair of the RHS780 to correct this problem is not covered by warranty.**

WEIGHT = XX.X LB  
AUTOMATIC? ←

▲▲

WEIGHT = XX.X LB  
VACUUM? ←

ENTER

\*

A/C HAS PRESSURE  
GO TO RECYCLE ←

ENTER

ENTER VACUUM  
TIME XX MIN ←

▲► ENTER

PERFORM LEAK  
TEST? Y/N ←

► ENTER

ADD OIL? Y/N ←

► ENTER

START? ←

ENTER

TIME LEFT = XX MIN  
PUMP ON

PUMP OFF XX MIN  
CONTINUE? ←

ENTER

ADD OIL NOW  
CONTINUE? ←

ENTER

## DEEP VACUUM

1. Setup the RHS780 as shown on Page 4 and then turn the Main Power Switch ON.
2. Attach the Red and Blue Hoses to the A/C System per the vehicle manufacturer's instructions and open the Red and Blue Hose Valves.
3. Using the Keypad, press the "Up Arrow" key two times to display "WEIGHT=XX.X LB" "VACUUM? ←" and press the ENTER key. The Display will read "ENTER VACUUM" "TIME XX MIN ←".
  - \* This screen will display if the RHS780 senses a pressure in either the High or Low Pressure Hoses. When this occurs, the A/C System must be emptied using the Recover/Recycle procedure on Page 6. Press the ENTER key to return to the Main Menu.
4. Press the "Up Arrow" key to change the value of the field. Press the "Right Arrow" key to change to a different field. The value entered must be greater than zero. Press the ENTER key to accept the value. The Display will read "PERFORM LEAK" "TEST? Y/N←".
5. Press the "Right Arrow" key to move the cursor between Y and N to select whether or not the RHS780 pauses at the end of Vacuuming so that a vacuum leak can be detected in the A/C System. Press the ENTER key to accept the Yes or No choice. The choice entered is stored in memory and comes up as the default the next time the procedure is used. The Display will read "ADD OIL? Y/N←".
6. Press the "Right Arrow" key to move the cursor between Y and N to select whether or not the RHS780 pauses at the end of Vacuuming (or Vacuum Leak Checking) to allow the Adding of Oil to the A/C System. Press the ENTER key to accept the Yes or No choice. The choice entered is stored in memory and comes up as the default the next time the procedure is used. The Display will read "START? ←".
7. Press the ENTER key to start the Vacuum Pump.

The Vacuum Pump will turn On, the Display will read "TIME LEFT=XX MIN" "PUMP ON" and the minutes remaining will count down on the Display. The Vacuum Pump will turn OFF when the Display reads zero minutes.
8. If a Vacuum Leak Check was selected by choosing Y in Step 5 the Display will read "PUMP OFF XX MIN" "CONTINUE? ←" and the Attention Light will turn ON. The elapsed time since the Vacuum Pump turned OFF will count up on the Display. An increasing pressure on the Low Pressure Gauge is evidence of a vacuum leak in the A/C System. Press the ENTER key to return to the Main Menu or to Add Oil if selected in Step 6.
9. If Adding Oil was selected by choosing Y in Step 6 the Display will read "ADD OIL NOW" "CONTINUE? ←", and the Attention Light will turn ON. Add oil to the correct side, either High or Low, based on the vehicle manufacturer's instructions, of the A/C System that will then be Charged during the Charging procedure on Page 9 by opening the valve on the Oil Charge Bottle and leaving it open until the correct amount of oil has left the Oil Charge Bottle. Close the valve on the Oil Charge Bottle and press the ENTER key to return to the Main Menu.

WEIGHT = XX.X LB  
AUTOMATIC? ←

▲▲▲

WEIGHT = XX.X LB  
CHARGE? ←

ENTER

ENTER CHARGE  
AMOUNT = XX.X LB ←

▲► ENTER

\*

LOW LEVEL, GO TO  
FILL CYLINDER ←

ENTER

CHECK HIGH-LOW  
CHARGE SWITCH ←

ENTER

WEIGHT = XX.X LB  
CHARGING

CHARGE COMPLETE  
EVAC HOSES ←

ENTER

## CHARGING

1. Setup the RHS780 as shown on Page 4 and then turn the Main Power Switch ON.
2. Attach the Red and Blue Hoses to the A/C System per the vehicle manufacturer's instructions and open the Red and Blue Hose Valves.
3. Determine the refrigerant capacity of the A/C System to be charged.

**Note: 1 oz = 0.02835 Kg & 1 Lb = 0.45359 Kg**

4. Using the Keypad, press the "Up Arrow" key three times to display "WEIGHT= XX.X LB" "CHARGE? ←" and press the ENTER key. The Display will read "ENTER CHARGE" "AMOUNT= XX.X LB ←".
5. Press the "Up Arrow" key to change the value of the field. Press the "Right Arrow" key to change to a different field. The value entered must be greater than zero. Press the ENTER key to accept the value. The Display will read "CHECK HIGH-LOW" "CHARGE SWITCH ←".

\* This screen will display if the RHS780 Charge Cylinder contains less refrigerant than the entered value. When this occurs, the charging Cylinder should be filled using the Fill Cylinder procedure on Page 5. Press the ENTER key to return to the Main Menu.

6. Based on the vehicle manufacturer's instructions, choose Charging through either the High Pressure Hose (preferred) or the Low Pressure Hose by pressing the top or bottom (respectively) of the High-Low Charge Selector Switch located on the rear of the RHS780 beside the Fill Cylinder Port .

**Note: Do Not Turn On The A/C System. SAE compliant refrigerant handling stations, like the RHS780, supply refrigerant in the liquid phase. Adding liquid refrigerant to a running A/C System may cause immediate A/C compressor failure.**

7. Press the ENTER key to start charging.

The Display will read "WEIGHT= XX.X LB" "CHARGING" as refrigerant leaves the Charging Cylinder. The weight displayed will be increasing from zero to the Charge Amount entered in Step 5 plus a one ounce (0.03 KG) "Over Charge" set at the factory to compensate for hose loss. (See Setting Over Charge Amount on Page 13 to change the default value.) When the RHS780 has finished the Display will read "CHARGE COMPLETE" "EVAC HOSES" and the Attention Light will turn ON.

8. Press the ENTER key to return to the Main Menu. The A/C System can now be turned on and tested by monitoring the High and Low Pressure Gauges.
9. Close the Red and Blue Hose Valves, disconnect them from the A/C System, and go to Page 6 (Recover/Recycle) to Evacuate the refrigerant from the Hoses.

WEIGHT = XX.X LB  
AUTOMATIC? ←

ENTER

RECYCLE HOLD  
TIME XX MIN ←

▲► ENTER

ENTER VACUUM  
TIME XX MIN ←

▲► ENTER

PERFORM LEAK  
TEST? Y/N ←

► ENTER

ADD OIL? Y/N ←

► ENTER

ENTER CHARGE  
AMOUNT = XX.X LB ←

▲► ENTER

\*  
LOW LEVEL, GO TO  
FILL CYLINDER ←

ENTER

CHECK HIGH-LOW  
CHARGE SWITCH ←

ENTER

CHECK HOSES  
START? ←

ENTER

WEIGHT = XX.X LB  
COMPRESSOR ON

## AUTOMATIC

1. Setup the RHS780 as shown on Page 4 and then turn the Main Power Switch ON.
2. Attach the Red and Blue Hoses to the A/C System per the vehicle manufacturer's instructions and open the Red and Blue Hose Valves.
3. Determine the refrigerant capacity of the A/C System to be charged.

**Note: 1 oz = 0.02835 Kg & 1 Lb = 0.45359 Kg**

4. Using the Keypad, press the ENTER key when the Display reads "WEIGHT= XX.X LB" "AUTOMATIC? ←" (this is the default screen of the Main Menu.) The Display will read "RECYCLE HOLD" "TIME XX MIN ←".

The Recycle Hold Time is the amount of time that the RHS780 waits for "out-gassing" or for the pressure in the A/C System being recovered to rise enough to automatically restart the recovery process. The minimum value is two (02) minutes. The value entered is stored in memory and comes up as the default the next time the procedure is used.

5. Press the "Up Arrow" key to change the value of the field. Press the "Right Arrow" key to change to a different field. Press the ENTER key to accept the value. The Display will read "ENTER VACUUM" "TIME XX MIN ←".
6. Press the "Up Arrow" key to change the value of the field. Press the "Right Arrow" key to change to a different field. Press the ENTER key to accept the value. The Display will read "PERFORM LEAK" "TEST? Y/N ←".
7. Press the "Right Arrow" key to move the cursor between Y and N to select whether or not the RHS780 pauses at the end of Vacuuming so that a vacuum leak can be detected in the A/C System. Press the ENTER key to accept the Yes or No choice. The choice entered is stored in memory and comes up as the default the next time the procedure is used. The Display will read "ADD OIL? Y/N ←".

8. Press the "Right Arrow" key to move the cursor between Y and N to select whether or not the RHS780 pauses at the end of Vacuuming (or Vacuum Leak Checking) to allow the Adding of Oil to the A/C System. Press the ENTER key to accept the Yes or No choice. The choice entered is stored in memory and comes up as the default the next time the procedure is used. The Display will read "ENTER CHARGE" "AMOUNT= XX.X LB ←".

9. Press the "Up Arrow" key to change the value of the field. Press the "Right Arrow" key to change to a different field. The value entered must be greater than zero. Press the ENTER key to accept the value. The Display will read "CHECK HIGH-LOW" "CHARGE SWITCH ←".

\* This screen will display if the RHS780 Charge Cylinder contains less refrigerant than the entered value. When this occurs, the charging Cylinder should be filled using the Fill Cylinder procedure on Page 5. Press the ENTER key to return to the Main Menu.

10. Based on the vehicle manufacturer's instructions, choose Charging through either the High Pressure Hose (preferred) or the Low Pressure Hose by pressing the top or bottom (respectively) of the High-Low Charge Selector Switch located on the rear of the RHS780 next to the Fill Port. Press the ENTER key when finished programming. The Display will read "CHECK HOSES" "START? ←".

**Note: Do Not Turn On The A/C System. SAE compliant refrigerant handling stations, like the RHS780, supply refrigerant in the liquid phase. Adding liquid refrigerant to a running A/C System may cause immediate A/C compressor failure.**

11. Press the ENTER key to start the RHS780 Automatic sequence.

WEIGHT = XX.X LB  
COMPRESSOR OFF

\*

HIGH PRESSURE  
SEE MANUAL

\*\*

CYLINDER FULL  
GO TO CHARGE ←

TIME LEFT = XX MIN  
PUMP ON

PUMP OFF XX MIN  
CONTINUE? ←

ENTER

ADD OIL NOW  
CONTINUE? ←

ENTER

WEIGHT = XX.X LB  
CHARGING

RECYCLED = XX.X LB  
EVAC HOSES ←

ENTER

DRAIN RECOVERED  
OIL NOW! ←

ENTER

## AUTOMATIC (continued)

The Display will read the "WEIGHT= XX.X LB" "COMPRESSOR ON". The RHS780 will recover and recycle refrigerant from the A/C System and automatically cycle OFF when a vacuum is sensed. This vacuum level can be seen on the Low Pressure Gauge. The Display will read "WEIGHT= XX.X LB" "COMPRESSOR OFF"

A small quantity of refrigerant will probably remain in the A/C System as observed by an increasing pressure on the Low Pressure Gauge. The RHS780 will automatically cycle ON to continue recovering refrigerant if pressure rises to a preset level. This automatic cycling will repeat resetting the Recycle Hold Timer each time. If a Vacuum Time greater than zero minutes was entered in Step 6, the Vacuum Pump will turn ON, the Display will read "TIME LEFT=XX MIN" "PUMP ON" and the minutes remaining will count down on the Display. The Vacuum Pump will turn OFF when the Display reads zero minutes.

12. Drain any recovered oil using the Drain Recovered Oil procedure on Page 7.
  - \* This screen will display if there is an internal fault. Please contact RTI Technical Support. Turn the RHS780 Power Switch OFF.
  - \*\* This screen will display when the Charging Cylinder fills to capacity, approximately 39.5 lbs (18 Kg.) If this occurs, the Weight can be lowered using the Charging procedure on Page 9 before the RHS780 can be used to recover more refrigerant. Press the ENTER key to return to the Main Menu.
13. If a Vacuum Leak Check was selected by choosing Y in Step 7 the Display will read "PUMP OFF XX MIN" "CONTINUE? ←" and the Attention Light will turn ON. The elapsed time since the Vacuum Pump stopped will count up on the Display. An increasing pressure on the Low Pressure Gauge is evidence of a vacuum leak in the A/C System. Press the ENTER key to continue with the Automatic sequence or RESET to return to the Main Menu.
14. If Adding Oil was selected by choosing Y in Step 8 the Display will read "ADD OIL NOW" "CONTINUE? ←" and the Attention Light will turn ON. Add oil to the side, either High or Low, based on the vehicle manufacturer's instructions, of the A/C System that will then be Charged during the Charging portion of the Automatic sequence by opening the valve on the Oil Charge Bottle and leaving it open until the correct amount of oil has left the Oil Charge Bottle. Close the valve on the Oil Charge Bottle and press the ENTER key to continue.
15. If a Charge Amount greater than zero pounds was entered in Step 9 the Display will read "WEIGHT= XX.X LB" "CHARGING" as refrigerant leaves the Charging Cylinder. The weight displayed will be increasing from zero to the Charge Amount entered plus a one ounce (0.03 KG) "Over Charge" set at the factory to compensate for hose loss. (See Setting Over Charge Amount on Page 13 to change the default value.) When the RHS780 has finished the Display will read "RECYCLED=XX.X LB" "EVAC HOSES" and the Attention Light will turn ON.
16. Press the ENTER key. The Display will read "DRAIN RECOVERED OIL NOW!". Drain any recovered oil using the Drain Recovered Oil procedure on Page 7.
17. Press the ENTER key to return to the Main Menu. The A/C System can now be turned on checked by monitoring the High and Low Pressure Gauges.
18. Close the Red and Blue Hose Valves, disconnect them from the A/C System and go to Page 6 (Recover/Recycle) to Evacuate the refrigerant from the Hoses.

```
WEIGHT = XX.X LB
AUTOMATIC? ←
```

▲▲▲▲ ENTER

```
WEIGHT = XX.X LB
SETUP? ←
```

ENTER

```
FILTER HOURS =
XX.X HOURS
```

▲

```
TOTAL RECYCLED =
XXXX.X KG
```

▲

```
TOTAL CHARGED =
XXXX.X KG
```

▲

## Accessing Stored Data

1. Setup the RHS780 as shown on Page 4 and then turn the Main Power Switch ON.
2. Using the Keypad, press the “Up Arrow” key five times to display “WEIGHT=XX.X LB” “SETUP? ←” and then press the ENTER key. The Display will read “FILTER HOURS=” “XX.X HOURS”.

See the Filter Maintenance section of the manual, Page 15, for the procedure to change the filters. The normal Filter Change Interval is after every 25 hours.

Note: Press and hold the “Right Arrow” key and press the RESET key to remove the “CHANGE FILTERS ←” message.

3. Press the “Up Arrow” key. The Display will read “TOTAL RECYCLED=” “XXXX.X KG”.
4. Press the “Up Arrow” key. The Display will read “TOTAL CHARGED=” “XXXX.X KG”.
5. Press the “Up Arrow” key to return to the Main Menu.

WEIGHT = XX.X LB  
 AUTOMATIC? ←

▲▲▲▲ ENTER

WEIGHT = XX.X LB  
 SETUP? ←

Calibration Switch

WEIGHT = XX.X LB  
 CHARGING

▲

OVER CHARGE  
 AMOUNT = X.XX KG ←

▲▶ ENTER

## Setting Over Charge Amount

1. Remove the front panel of the RHS780.
2. Turn the Main Power Switch ON. Refer to the figure below to locate the access hole to the Calibration Switch [B] which is on the underside of the Circuit Board Cover [C] left of the LCD.
3. Remove the plastic Calibration Tool [A] from the lower mounting hole of the Circuit Board Cover [C] next to the access hole to the Calibration Switch [B].
4. Using the Keypad, press the "Up Arrow" key five times to display "WEIGHT= XX.X LB" "SETUP? ←" and press the Calibration Switch [B]. The Display will read "WEIGHT= XX.X LB" "CHARGING".
5. Press the "Up Arrow" key. The Display will read "OVER CHARGE" "AMOUNT= X.XX KG←".
6. Press the "Up Arrow" key to change the value of the field. Press the "Right Arrow" key to change to a different field. The value entered will be stored until this procedure is run again and a new value is entered. Press the ENTER key to accept the value. The Display will then return to the Main Menu.

**Note:** 1 oz = 0.02835 Kg and 1 Lb = 0.45359 Kg

7. Replace the front panel of the RHS780.

**Note:** Calibration Tool Part No. 360-81214-00

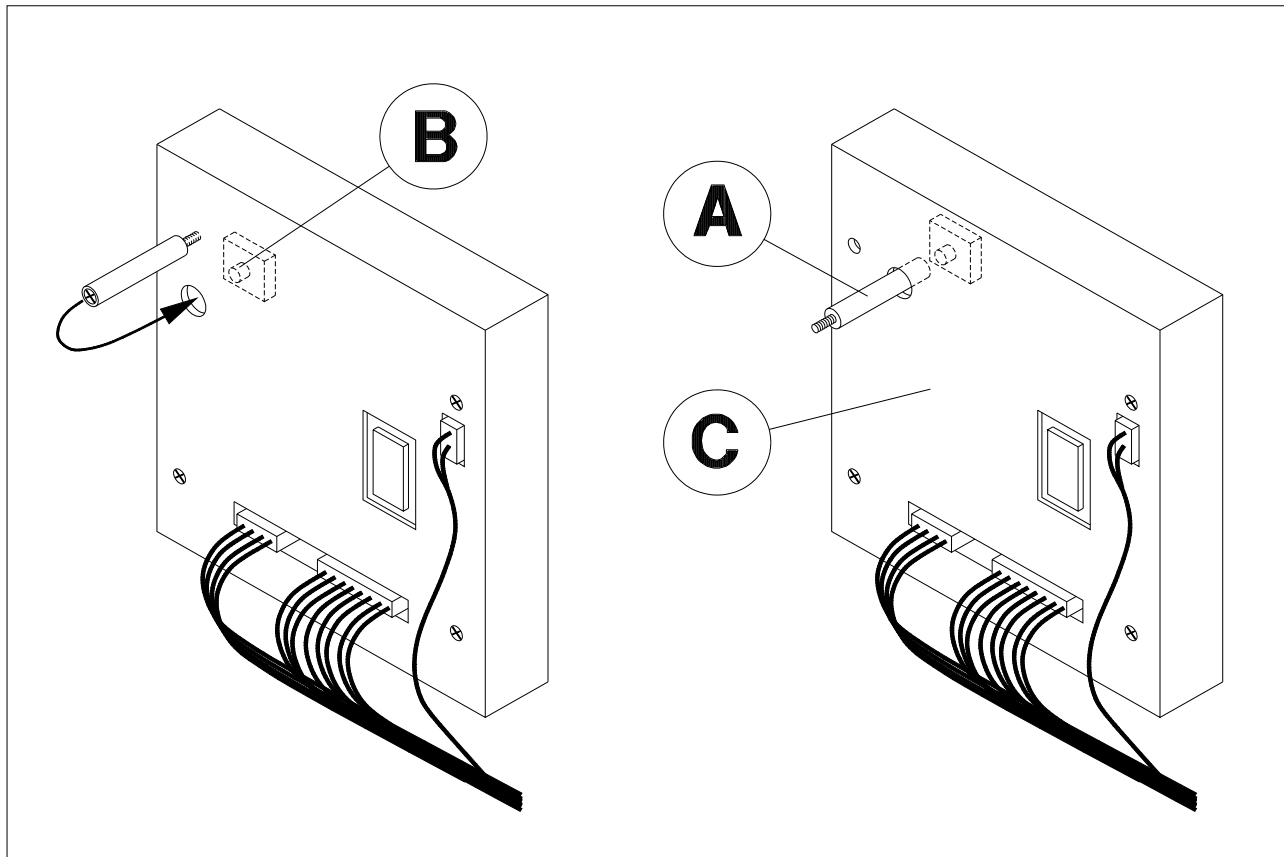

# SCHEDULED MAINTENANCE

## DAILY...

Check the oil level in the Vacuum Pump while the pump is running. The Vacuum Pump Oil Level Sight Glass is visible through vacuum pump sight glass on the rear of the RHS780. The oil level should be at the “half-way” point of the glass. If oil is not visible call Technical Support at 800-468-2321 extension 259.

## MONTHLY...

Clean the Condenser to maintain high efficiency performance of the RHS780. Disconnect power and remove the plastic front cover and blow compressed air through the cooling fins of the Condenser to remove any debris. Do not bend the fins on the Condenser coils. Air flow will be restricted causing damage to the RHS780. Replace the panel before applying power to the RHS780.

# FILTER MAINTENANCE

The RHS780 automatically keeps track of Compressor Run Time. The Display will read “CHANGE FILTERS ←” after every 25 hours every time the program returns to the Main Menu or whenever the RHS780 is turned on as a reminder to change the filters. Press ENTER ← to go to the Main Menu.

The “INLET” Combo Filter (left side) must be changed after every 25 hours of operation. RTI part number 026-80077-00.

The “OUTLET” Combo Filter (right side) must be changed after every 50 hours of operation. RTI part number 026-80069-00.

The Hours Counter is reset when the “CHANGE FILTERS ←” message is cleared. Record the filter changes performed to track when only the “INLET” Combo Filter is changed versus when both are changed.

Change the filters as described below:

1. Disconnect Flare Fittings from top and bottom of filters.
2. Remove mounting nuts and filters.
3. Transfer filter insulation material to new filter as applicable.
4. Install new Combo Filters using hardware removed in Step 2.
5. Connect Flare Fittings to top and bottom of filters.
6. Check for leaks and repair as necessary.
7. Go to Page 12, Accessing Stored Data, for instructions on how to remove the “CHANGE FILTERS ←” message.



# PARTS IDENTIFICATION

## Front View

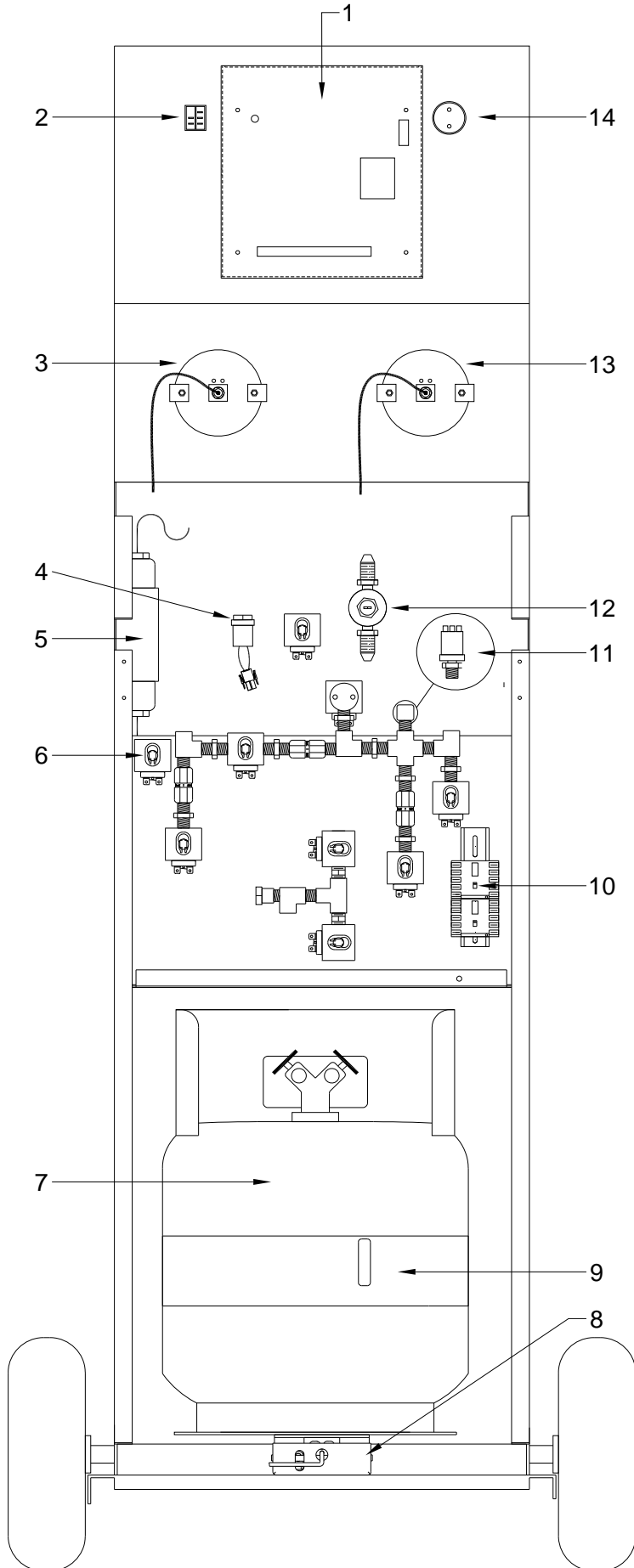

	P/N	DESCRIPTION
1	024-80105-01	Circuit Board 120V
2	024-80040-00	Rocker Switch SPDT (on-on) Amber (125V)
3	026-80065-03	Gauge 30"-120 Psig 1/4 MFL 3.5"
4	360-81307-00	High Pressure Switch 120V
5	022-80024-00	D/P Switch R134A
6	360-81292-00	Solenoid w/MOV Assy 120V
7	360-81895-00	Cylinder Assy 50 lbs.
8	031-80004-00	Load Cell 50 KG (Shock Mount)
9	360-81426-01	Heater Belt Assy
10	024-80037-00	Contactor 1/2 HP (120V) 3NC - 1NC
11	360-81314-00	Low Pressure Switch 3psig-15 In-Hg SPDT
12	022-80110-00	Valve Automatic Expansion 3/8 MFL x 3/8 MFL
13	026-80071-03	Gauge 0-500 Psig 1/4 MFL 3.5"
14	025-80127-00	Clear Bulb Bayonet Base 120V
	025-80191-00	Lens Assembly Yellow

# PARTS IDENTIFICATION (RHS780)

## Rear View

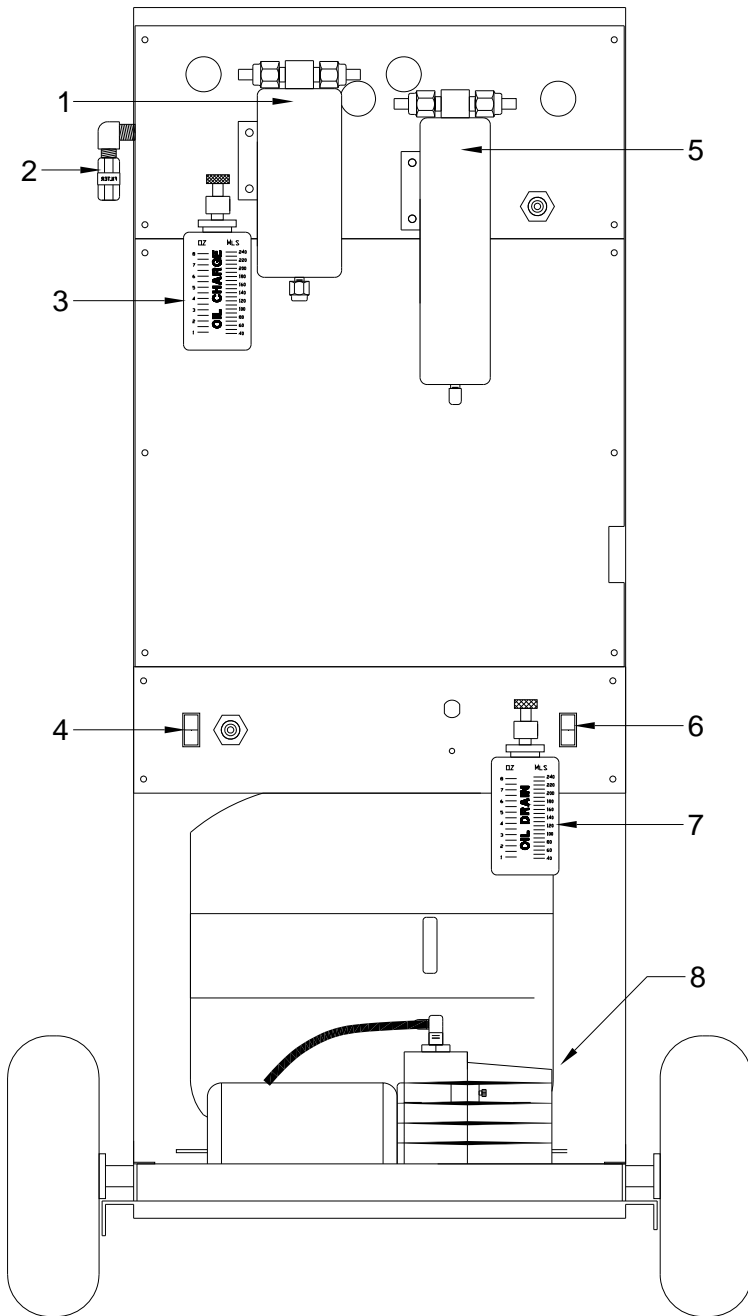

	P/N	DESCRIPTION
1	026-80069-00	Combo Filter 3/8 Flare (Short)
2	026-80240-00 026-80241-00	Filter In-Line (R12) Filter In-Line (R134a)
3	026-80208-00 026-80208-01	Oil Charge Bottle Assy Oil Charge Bottle Only
4	024-80066-00	Rocker Switch SPDT (ON-ON) Visi-Red
5	026-80077-00	Combo Filter 3/8 Flare (Long)
6	024-80035-00	Rocker Switch SPST (MOM-ON) non-lighted
7	026-80207-00 026-80207-01	Oil Drain Bottle Assy Oil Drain Bottle Only
8	026-80229-00	Pump Vac 7 CFM (110V/220V)
9	360-81439-00	Condenser Assy
10	360-80416-00	Fan Assy 120V
11	360-81670-01	Compressor Assy 120V
12	026-80070-00	Accumulator

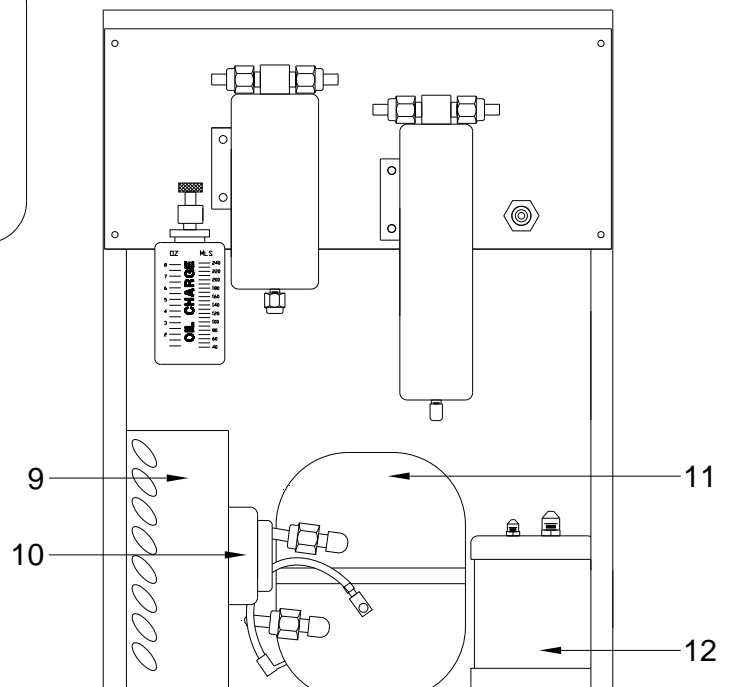

# Solenoid, Pressure Switch & Contactor Identification

