

OPERATION  
&  
MAINTENANCE  
MANUAL

**RHS680**

Refrigerant Handling System

**RTI** **TECHNOLOGIES, INC.**

4075 East Market Street  
York, PA 17402  
800-468-2321  
tech@rtitech.com

Manual P/N 035-80912-00

## TABLE OF CONTENTS

Startup & Safe Operation . . . . .	1
Introduction to the RHS680 . . . . .	2
Control Panel . . . . .	3
Keypad Functions . . . . .	4
First Time Use of the RHS680 . . . . .	5
Start-Up . . . . .	6
Recover (Recycle) . . . . .	7
Purge Air - Drain Oil . . . . .	7
Vacuum . . . . .	8
Charge . . . . .	8
Maintenance . . . . .	9
Parts Lists . . . . .	10
R134a Connection to Cylinder . . . . .	11

### TECHNICAL SUPPORT

RTI Technologies has a staff of qualified technicians available for technical support. We also maintain one of the largest networks of Service Centers throughout the world for unit repairs and maintenance. Our web site is constantly updated to provide the latest information concerning all the products we manufacture.

RTI Technologies, Inc.  
York, Pennsylvania USA

800-468-2321  
717-840-0678

[www.rtitech.com](http://www.rtitech.com)

## STARTUP & SAFE OPERATION

- Do not use a damaged unit. Check for shipping damage and place a claim with carrier if damage is discovered.
- Return the Warranty Card to activate technical support service and warranty coverage.
- The RHS680 should not be operated or serviced by any person who has not read all the contents of this manual.
- This manual describes normal operation and maintenance for the RHS680. Failure to read and comply with these instructions or any one of the limitations noted herein can result in serious injury and/or property damage. The instructions should not be interpreted to anticipate every possible contingency.
- It is the responsibility of the owner/user to operate the RHS680 in accordance with all laws and specifications which may apply.
- Recover (recycle) and charge only the refrigerant for which the RHS680 is configured.
- Avoid breathing refrigerant or lubricant vapor. Exposure may irritate eyes, nose and throat. Ventilate work area if accidental system discharge occurs.
- Wear safety glasses and protective gloves. Refrigerant has a very low boiling point and can cause frostbite.
- Follow the RHS680 operating procedures sequentially to avoid prematurely disconnecting hoses or opening valves which may release refrigerant to the atmosphere.
- Do not expose the RHS680 to moisture or operate in wet areas.
- Use the RHS680 in locations with ventilation that provides at least four air changes per hour.
- Hoses must have shutoff devices within 12 inches of the connection point to the A/C to minimize the introduction of air into the RHS680 and the release of refrigerant when being disconnected.
- Avoid using an extension cord with the RHS680. If necessary use a good condition, three wire grounded, #14 AWG or larger extension cord of the shortest possible length.
- Disconnect power before performing any maintenance or service on the RHS680.
- Do not connect the red or blue hoses to the liquid port of a cylinder of refrigerant to fill the charge cylinder. Doing so may cause the compressor to fail and void the warranty.
- Do not connect the RHS680 to the liquid side of any A/C with a capacity greater than 4 lbs. Refrigerant in A/C Systems having larger capacities must be recovered from the vapor side only.

### Special Considerations with R134a

R134a has been shown to be nonflammable at ambient temperature and atmospheric pressure. However, tests under controlled conditions have indicated that at pressures above atmospheric and with air concentrations greater than 60 percent by volume, R134a can form combustible mixtures.

While it is recognized that an ignition source is also required for combustion to occur, the presence of combustible mixtures is a potentially dangerous situation and should be avoided.

Under no circumstances should any equipment be pressure tested or leak tested with air and R134a mixtures. Do not use compressed air for leak detection in R134a systems.

# INTRODUCTION TO THE RHS680

The RHS680 is a complete refrigerant management center featuring state-of-the-art electronic control with digital weight scale measuring of refrigerant. Operation of the RHS680 is intuitive and very easy to master.

Following is an overview of the operation and features of the RHS680:

## RECOVER (RECYCLE)

Refrigerant is recovered from the A/C, impurities (particulates, oil, moisture and air) are removed and the refrigerant is stored in the internal cylinder. The recovery process stops when the RHS680 senses an 8 InHg vacuum at the A/C. Wait for at least two minutes and watch the pressure gauges to determine if there is an increasing pressure. If pressure in the A/C rises during this time period due to vaporization of residual liquid refrigerant, the RHS680 will restart to recover this refrigerant. When the RHS680 stays off continually for at least two minutes, the recovery procedure is complete.

## VACUUM

A deep vacuum should be drawn on the A/C to remove air, moisture and refrigerant dissolved in the oil. A deep vacuum is especially important if the A/C was opened for replacement of components.

## PURGE AIR - DRAIN OIL

Excess air and recovered oil must be removed from the RHS680 after all refrigerant has been recovered from the A/C. Temperature and pressure readings are examined and air is released using the purge valve. Oil is drained into the oil drain cup for measuring to determine the need to replenish the A/C.

## CHARGE

Refrigerant is charged into the A/C by weight. The amount to be charged is entered and the RHS680 automatically charges the refrigerant into the A/C.

- 1 Keypad
- 2 Function Valve
- 3 Purge Chart
- 4 Gauge Manifold
- 5 Tool Tray
- 6 Purge Gauge
- 7 Purge Valve

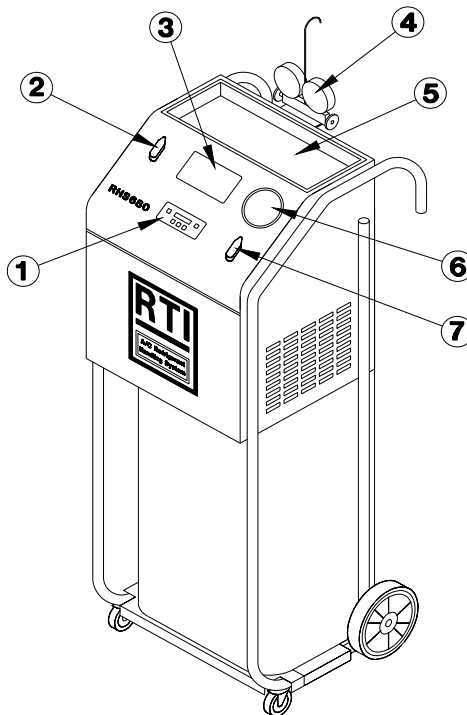

# CONTROL PANEL

## PURGE CHART - °F & PSIG

°F	R12	R134a	°F	R12	R134a	°F	R12	R134a
32	44	42	64	83	85	96	138	148
34	46	44	66	85	88	98	143	153
36	48	46	68	88	92	100	147	157
38	50	49	70	92	95	102	150	163
40	52	51	72	95	97	104	155	167
42	54	54	74	98	104	106	160	173
44	57	56	76	102	107	108	165	180
46	59	59	78	105	110	110	168	185
48	61	61	80	108	114	112	173	190
50	64	64	82	112	118	114	178	195
52	66	67	84	115	123	116	183	200
54	69	70	86	118	127	118	188	207
56	72	72	88	123	130	120	193	213
58	74	76	90	127	135			
60	77	78	92	130	140			
62	80	82	94	135	145			

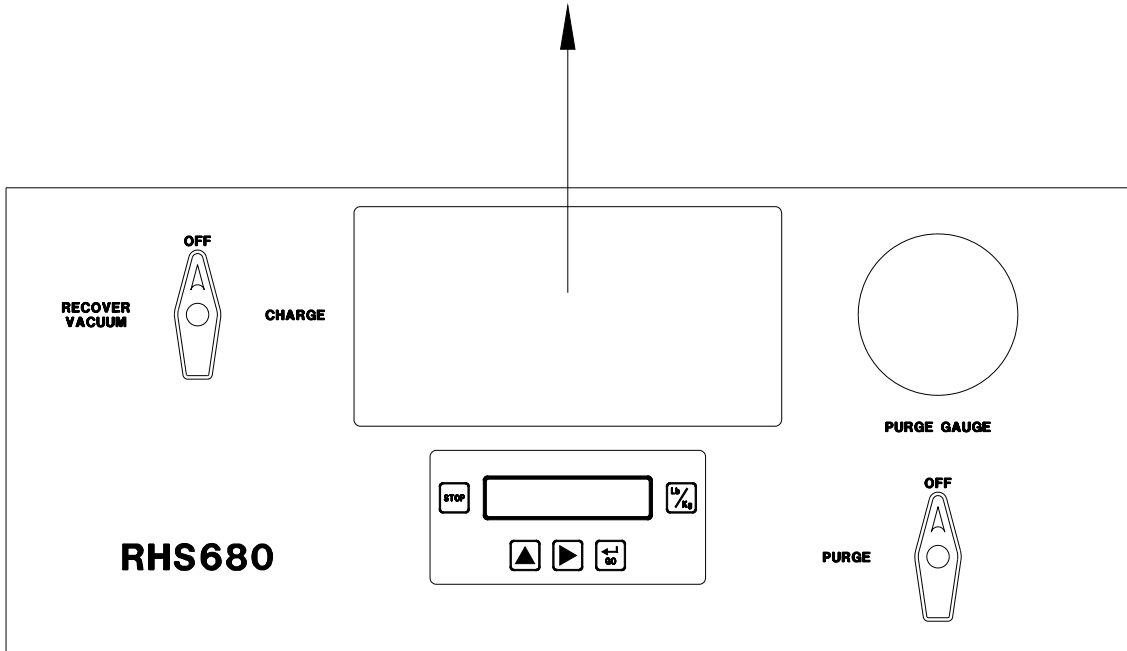

# KEYPAD FUNCTIONS

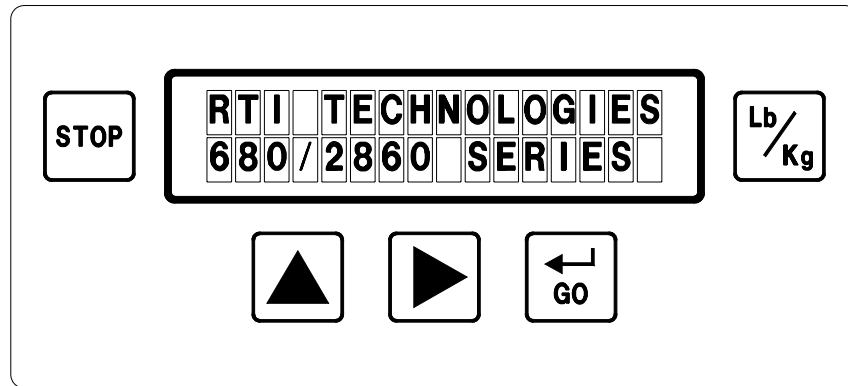

## Scroll Key

Press to scroll through function options or to increase numeric values shown on the display.



## Cursor Key

Press to move flashing cursor on the display prior to numeric entries.



## Go Key

Press to confirm data entry and continue.



## Stop Key

Press to halt program sequence.



## Units Key

Press to change unit of measure for weight displays.

## - CAUTION -

**Always use fingers to operate keypad.  
Use of sharp objects will cause damage.**

## FIRST TIME USE OF THE RHS680

1. The RHS680 ships from the factory with all internal components in a vacuum. It should be pre-charged with refrigerant for optimum performance. The cylinder mounted in the RHS680 is used as the storage container for recycled refrigerant. This same refrigerant is then charged to the A/C System during a charge procedure. This cylinder must be left in the RHS680, as the weight scale is calibrated for this specific cylinder.
2. Connect the gauge manifold and cylinder of new refrigerant to the RHS680 as shown. See Page 11 for R134a hose connection to cylinder.

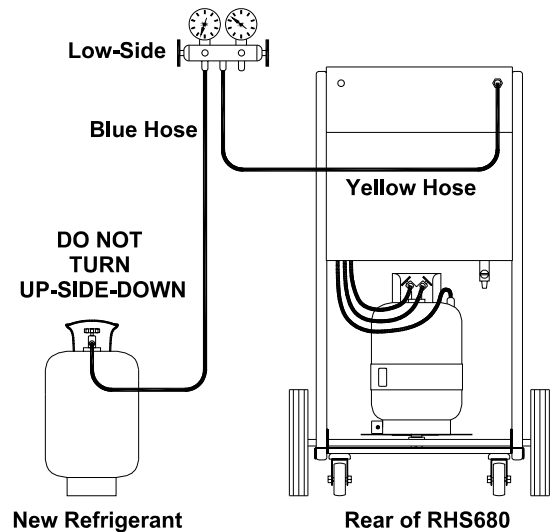

**DO NOT TURN THE CYLINDER OF NEW REFRIGERANT UP-SIDE-DOWN AS LIQUID REFRIGERANT WILL BE INTRODUCED INTO THE RHS680. COMPRESSOR DAMAGE COULD RESULT WHICH VOIDS THE WARRANTY.**

3. Turn Purge Valve on RHS680 to OFF. Turn Function Valve on RHS680 to RECOVER. Open low side valve on gauge manifold. Open valve on cylinder of new refrigerant.
4. Connect power cord of RHS680 to properly grounded power source. Avoid using an extension cord. If necessary use a good condition, three wire grounded, #14 AWG or larger extension cord of the shortest possible length.
5. RTI TECHNOLOGIES and 680/2860 SERIES will display for ten seconds.
6. The display will show the weight of refrigerant in the RHS680 cylinder and prompt RECYCLE? The weight of refrigerant will initially display zero.
7. Press [←] key to begin a recycle procedure. Refrigerant will be drawn from the cylinder of new refrigerant and stored in the cylinder on the RHS680. The weight displayed will begin to increase after approximately one pound of refrigerant is used to initially fill internal components of the RHS680. Close the valve on the new refrigerant cylinder when the display shows a recommended 2 to 3 pounds. More than this amount can be added to the RHS680 cylinder if desired. The maximum capacity is 24 pounds.
8. When all refrigerant in the hoses and gauge manifold has been recovered, the display will show RECYCLE COMPLETE CHECK PRESSURES.
9. Press the stop key and turn the Function Valve to OFF.
10. Close the low side valve on the gauge manifold.
11. Disconnect the blue hose from the cylinder of new refrigerant.

The above procedure can be used anytime it is necessary to add new refrigerant to the RHS680 cylinder.

## START-UP

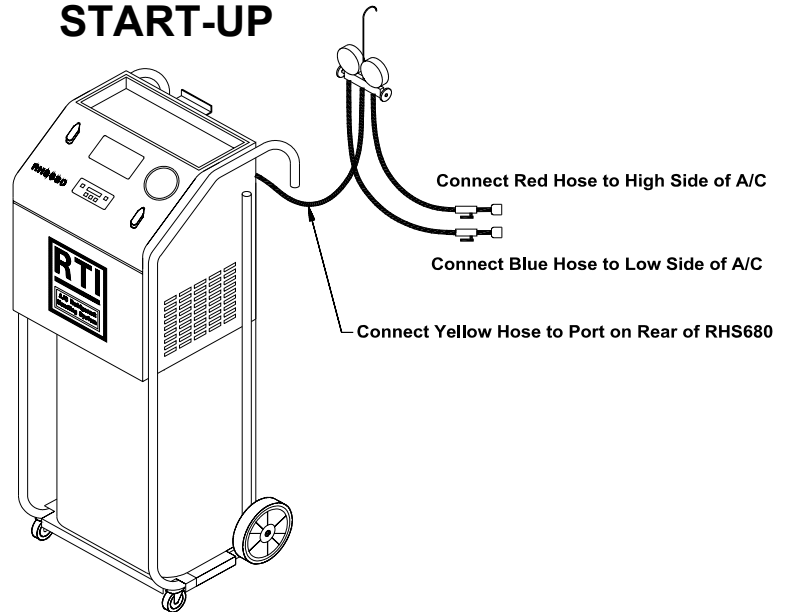
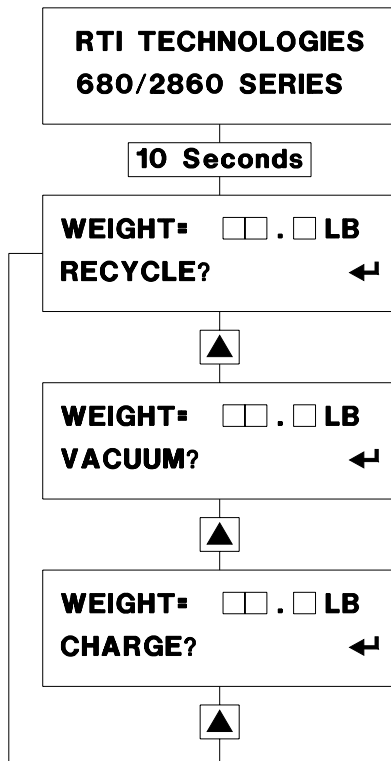

1. Turn Function Valve and Purge Valve on RHS680 to OFF. Connect yellow hose of gauge manifold to port on rear of RHS680. Close high and low valves on gauge manifold. Connect red and blue hoses to A/C system and open hose valves.
2. Connect power cord of RHS680 to properly grounded power source. Avoid using an extension cord. If necessary use a good condition, three wire grounded, #14 AWG or larger extension cord of the shortest possible length.

3. RTI TECHNOLOGIES and 680/2860 SERIES will display for ten seconds.
4. The display will then show the weight of refrigerant in the RHS680 cylinder and prompt RECYCLE?
5. Press [←] key to begin a recycle procedure (Page 7) or press [▲] key to go to next screen (See next step).
6. The display will show the weight of refrigerant in the charge cylinder and prompt VACUUM?

### \*\*\*\*\* CAUTION \*\*\*\*\*

Make sure the A/C pressures are at zero or below. If the gauges indicate positive pressure, refrigerant will be vented to the atmosphere. Perform a recover procedure before starting a vacuum procedure.

7. Press [←] key to begin a vacuum procedure (Page 8) or press [▲] key to go to next screen (See next step).
8. The display will show the weight of refrigerant in the charge cylinder and prompt CHARGE?
9. Press [←] key to begin a charge procedure (Page 8) or press [▲] key to return to Step 4 above.



## RECOVER (RECYCLE)

**WEIGHT=** □□ . □ **LB**  
**RECYCLING**

**RECYCLE COMPLETE**  
**CHECK PRESSURES**

**CYLINDER FULL**  
**GO TO CHARGE**

1. Turn Function Valve on RHS680 to RECOVER.
2. Open high and low valves on gauge manifold.
3. The display will show the weight of refrigerant in the RHS680 cylinder and indicate the unit is recycling.
4. When the A/C system pressure is in a vacuum the display will show RECYCLE COMPLETE CHECK PRESSURES. Wait two minutes to see if the pressure in the A/C increases (due to liquid refrigerant vaporizing). The RHS680 will automatically begin recycling again if the pressure rises above zero.
5. Press the stop key and close the high and low valves on the gauge manifold.
6. Turn Function Valve on RHS680 to OFF.

### Note:

The display will show CYLINDER FULL GO TO CHARGE if the RHS680 cylinder fills to capacity. Press the STOP key and perform a charge procedure to transfer refrigerant to another A/C system or an external storage cylinder.

## PURGE AIR - DRAIN OIL

**IMPORTANT: Oil must be drained and Air purged after each recover (recycle) procedure. Failure to do so will cause excess air to be introduced into the A/C during charge and the RHS680 will fill with air causing a high-pressure shutdown.**

1. The oil drain valve is accessible from the rear of the RHS680, located under the main enclosure on the right side (when viewed from rear). Open the Purge Valve for 5 seconds and then close it. **Slowly** open the oil drain valve and drain any oil into the measuring cup to determine how much oil (if any) should be added to the A/C.
2. Leave the oil drain valve open.
3. Measure the room temperature.
4. Find the corresponding pressure for this temperature on the purge chart printed on the RHS680 top panel.
5. Compare this pressure from the chart with that indicated on the Purge Gauge. If the gauge shows a higher pressure, **slowly** open the Purge Valve a **small** amount until the pressure drops to approximately the pressure shown in the chart.
6. Turn the purge valve to OFF.
7. Close the oil drain valve.

## VACUUM

**WEIGHT=**   .  **LB**  
**VACUUMING**

1. **MAKE SURE THE GAUGE PRESSURES ARE ZERO OR LESS.** If not, a recover procedure must be performed before starting the vacuum procedure.
2. Turn Function Valve on RHS680 to VACUUM.
3. Open high and low valves on gauge manifold.
4. The display will show the weight of refrigerant in the RHS680 cylinder and indicate the unit is vacuuming.
5. At the end of the desired vacuum time, press the stop key and close the high and low valves on the gauge manifold.
6. Turn Function Valve on RHS680 to OFF.

## CHARGE

**ENTER CHARGE**  
**AMOUNT=**   .  **LB** ←

**WEIGHT=**   .  **LB**  
**CHARGING**

**CHARGE COMPLETE**  
**EVACUATE HOSES**

1. Open either the low or high valve on gauge manifold and corresponding hose valve according to the A/C manufacturer's recommendation for charging the system.
2. Enter weight of charge desired using the keypad. Press the [▲] key to increase numeric value shown on display and press [▶] key to move flashing cursor to next position. Press [←] key to start charging.
3. Turn Function Valve on RHS680 to CHARGE.
4. Do not run the A/C during the charge procedure.
5. The display will show the amount of refrigerant being charged into the A/C.
6. The display will show CHARGE COMPLETE EVACUATE HOSES when the correct amount of refrigerant has been charged.
7. Press the stop key and close the hose valve.
8. Turn function valve to OFF.
9. Evacuate the hose by running a recycle procedure.

### Note:

The display will show LOW LEVEL GO TO RECYCLE if the RHS680 cylinder does not contain enough refrigerant to complete the charge weight entered. Press the STOP key and perform a recycle procedure to transfer refrigerant into the RHS680 cylinder.

**LOW LEVEL. GO TO**  
**RECYCLE**

# MAINTENANCE

The RHS680 will provide many years of reliable service if properly maintained. Following is a checklist of items which will ensure the RHS680 performs at peak efficiency and presents an image to your customers that your shop performs high tech A/C service.

1. Use tool tray for storage of tools and accessory adapters.
2. Store gauge manifold and hoses properly when not in use. Avoid hanging hoses over the top of the unit.
3. Keep the exterior surfaces clean. Use a mild all purpose cleaner to wipe oil and dirt off the cabinet.
4. Do not allow the unit to sit outside in direct sunlight or inclement weather. Excessive exposure to sun light and moisture may cause damage and will void the warranty.
5. The RHS680 is not intended to be used for mobile A/C service where the unit is transported to customer sites. Excessive vibration will shorten component life.
6. Be gentle when moving the RHS680 around the shop. Tip the unit and ease the front casters over any obstacles such as door jams, air hoses and floor irregularities.
7. Periodically remove the front cover and check for refrigerant leaks inside the RHS680 using a leak detector. A small leak detected early will prevent future undetected loss of refrigerant.
8. Use regulated, clean shop air to remove debris from the fins of the condenser coil. Be careful and do not disturb any internal components.
9. **During filter changes every 25 hours, it is IMPERATIVE for the longevity of the RHS680, that two ounces of compressor Poly Ester Oil (POE - RTI P/N 011-80021-00) be added to the compressor to replenish oil lost during the previous 25 hours of operation. Not adding oil at recommended intervals or using oil other than RTI P/N 011-80021-00 will void the warranty.**
10. Periodically check the oil level in the vacuum pump (if installed). Oil should be visible half way up the sight glass while the vacuum pump is running. If the oil level is low, call RTI Technical Support 800-468-2321.

## FILTER CHANGE & ADDITION OF COMPRESSOR OIL

Filters (see next page for RTI part numbers) must be changed and oil must be added to the compressor after every 25 hours of recycling refrigerant. The display will show "CHANGE FILTERS +2OZ - COMP OIL". This reminder will be displayed whenever the RHS680 is turned on or a new procedure is started.

Disconnect power and remove tool tray from top of RHS680. Use end wrench to loosen and tighten copper tube fittings on filters. The foam insulation on the smaller outlet filter must be removed from the old filter and reinstalled on the new one. Check for leaks after replacing filters.

Locate compressor oil fill port (tag attached to port). Remove plug from the fill tube using two end wrenches. Fill the syringe (supplied with RHS680) with two ounces of oil (RTI P/N 011-80021-00). Apply power and place RHS680 in Vacuum Mode. Insert tip of syringe in fill port and inject the two ounces of oil. The vacuum will pull the oil into the compressor. Press Stop. Disconnect power and install plug on fill tube using two end wrenches.

Apply power. The display will show "CHANGE FILTERS +2OZ - COMP OIL". While this message is displayed, press and hold the [▶] key and the [▲] key for two seconds to reset.

# PARTS LIST - RHS680

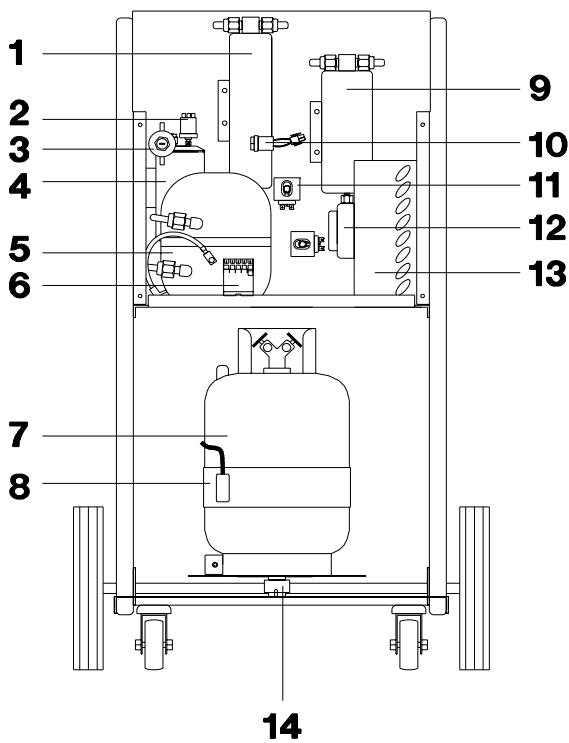
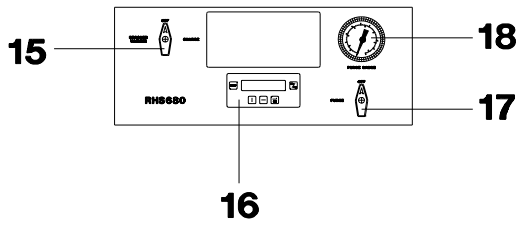

	Part Number	Description
1	026-80077-00	Filter - Long
2	022-80013-00	Low Pressure Switch
3	022-80110-00	Expansion Valve Assy
4	026-80070-00	Accumulator
5	360-81670-01	Compressor
6	024-80037-00	Contactora
7	360-81428-00	DOT Cylinder
8	360-81547-01	Heat Belt
9	026-80069-00	Filter - Short
10	022-80015-02	High Pressure Switch
11	025-80304-00	Solenoid
12	360-80416-00	Fan Assy
13	360-80280-00	Condenser Assy
14	031-80000-00	Load Cell
15	022-80028-00	Valve - 3 Way
16	024-80070-00 024-80072-00	Keypad Circuit Board
17	022-80027-00	Valve - 2 Way
18	026-80071-02	Gauge

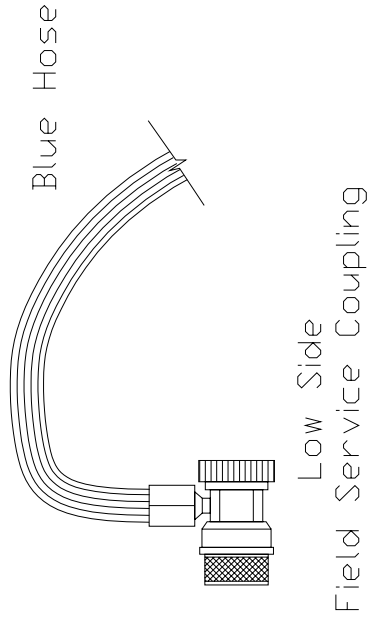

Install Adapter on Port slightly more than finger tight



P/N 023-80147-00

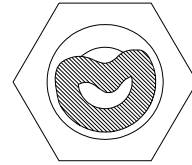
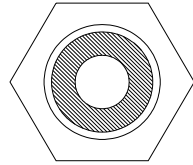
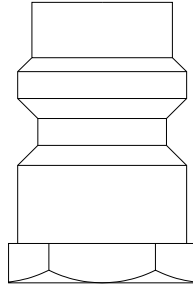
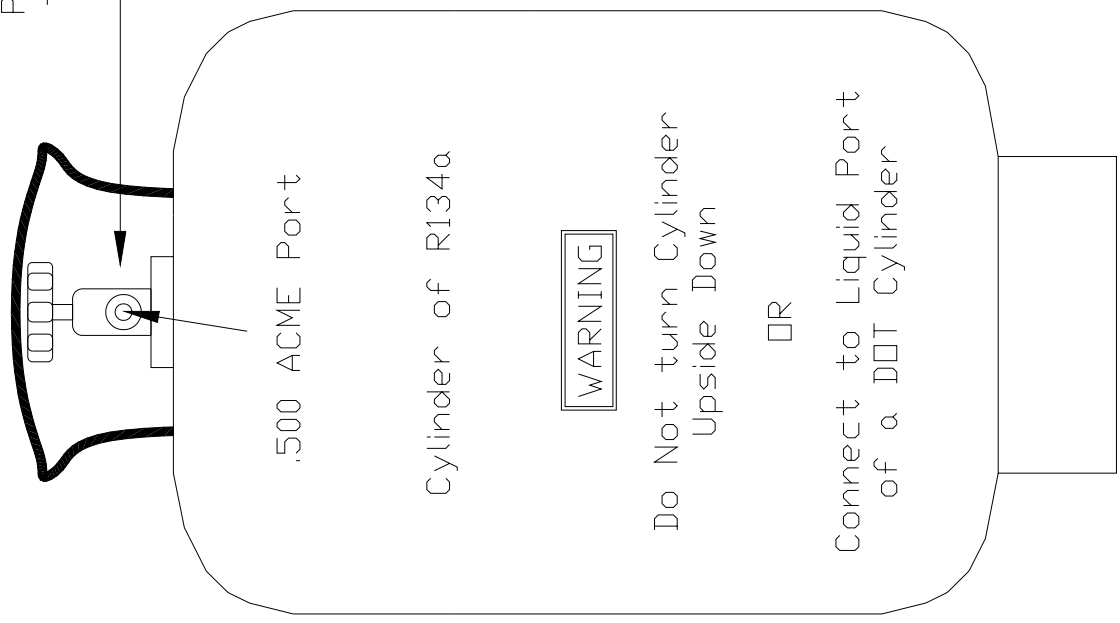

Over-tightening will distort O-ring and cause Port to be blocked as shown

Insert a round tool or piece of 14 ga wire through O-ring during tightening to prevent the O-ring from deforming