

OPERATION
&
MAINTENANCE
MANUAL

AC2860

Refrigerant Handling System



Manual P/N 035-80750-00

TABLE OF CONTENTS

| | |
|--------------------------------------|---|
| Startup & Safe Operation | 1 |
| Introduction to the AC2860 | 2 |
| Control Panel | 3 |
| Keypad Functions | 4 |
| Start-Up | 5 |
| Recover (Recycle) | 6 |
| Purge Air - Drain Oil | 6 |
| Vacuum | 7 |
| Charge | 7 |
| Maintenance | 8 |
| Parts Lists | 9 |

CONGRATULATIONS

You have purchased one of the finest Recovery, Recycling, and Charging Machines available!

Your AC2860 was proudly manufactured for MATCO Tools by RTI Technologies Inc., York, PA.

Fill out and return the Warranty Card within 90 days to activate the warranty and free lifetime technical support.

TECHNICAL SUPPORT

800-468-2321 (Ext. 259)

tech@rtitech.com

STARTUP & SAFE OPERATION

- Do not use a damaged unit. Check for shipping damage and place a claim with carrier if damage is discovered.
- Return the Warranty Card to activate technical support service and warranty coverage.
- The AC2860 should not be operated or serviced by any person who has not read all the contents of this manual.
- This manual describes normal operation and maintenance for the AC2860. Failure to read and comply with these instructions or any one of the limitations noted herein can result in serious injury and/or property damage. The instructions should not be interpreted to anticipate every possible contingency.
- It is the responsibility of the owner/user to operate the AC2860 in accordance with all laws and specifications which may apply.
- Recover (recycle) and charge only the refrigerants for which the AC2860 is configured.
- Avoid breathing refrigerant or lubricant vapor. Exposure may irritate eyes, nose and throat. Ventilate work area if accidental system discharge occurs.
- Wear safety glasses and protective gloves. Refrigerant has a very low boiling point and can cause frostbite.
- Follow the AC2860 operating procedures sequentially to avoid prematurely disconnecting hoses or opening valves which may release refrigerant to the atmosphere.
- Do not expose the AC2860 to moisture or operate in wet areas.
- Use the AC2860 in locations with ventilation that provides at least four air changes per hour.
- Hoses must have shutoff devices within 12 inches of the connection point to the A/C to minimize the introduction of air into the AC2860 and the release of refrigerant when being disconnected.
- Avoid using an extension cord with the AC2860. If necessary use a good condition, three wire grounded, #14 AWG or larger extension cord of the shortest possible length.
- Disconnect power before performing any maintenance or service on the AC2860.
- Do not connect the red or blue hoses to the liquid port of a cylinder of refrigerant to fill the charge cylinder. Doing so may cause the compressor to fail and void the warranty.
- Do not connect the AC2860 to the liquid side of any A/C with a capacity greater than 4 lbs. Refrigerant in A/C Systems having larger capacities must be recovered from the vapor side only.

Special Considerations with R134a

R134a has been shown to be nonflammable at ambient temperature and atmospheric pressure. However, tests under controlled conditions have indicated that at pressures above atmospheric and with air concentrations greater than 60 percent by volume, R134a can form combustible mixtures.

While it is recognized that an ignition source is also required for combustion to occur, the presence of combustible mixtures is a potentially dangerous situation and should be avoided.

Under no circumstances should any equipment be pressure tested or leak tested with air and R134a mixtures. Do not use compressed air for leak detection in R134a systems.

INTRODUCTION TO THE AC2860

The AC2860 is a complete refrigerant management center featuring state-of-the-art electronic control with digital weight scale measuring of refrigerant. Operation of the AC2860 is intuitive and very easy to master.

Following is an overview of the operation and features of the AC2860:

RECOVER (RECYCLE)

Refrigerant is recovered from the A/C, impurities (particulates, oil, moisture and air) are removed and the refrigerant is stored in the internal cylinder. The recovery process stops when the AC2860 senses an 8 InHg vacuum at the A/C. Wait for at least two minutes and watch the pressure gauges to determine if there is an increasing pressure. If pressure in the A/C rises during this time period due to vaporization of residual liquid refrigerant, the AC2860 will restart to recover this refrigerant. When the AC2860 stays off continually for at least two minutes, the recovery procedure is complete.

VACUUM

A deep vacuum should be drawn on the A/C to remove air, moisture and refrigerant dissolved in the oil. A deep vacuum is especially important if the A/C was opened for replacement of components.

PURGE AIR - DRAIN OIL

Excess air and recovered oil must be removed from the AC2860 after all refrigerant has been recovered from the A/C. Temperature and pressure readings are examined and air is released using the purge valve. Oil is drained into the oil drain cup for measuring to determine the need to replenish the A/C.

CHARGE

Refrigerant is charged into the A/C by weight. The amount to be charged is entered and the AC2860 automatically charges the refrigerant into the A/C.

- 1 R12/R134a Selector Switch
- 2 Keypad
- 3 Function Valve
- 4 Purge Chart
- 5 Gauge Manifold
- 6 Tool Tray
- 7 Purge Gauge
- 8 Purge Valve

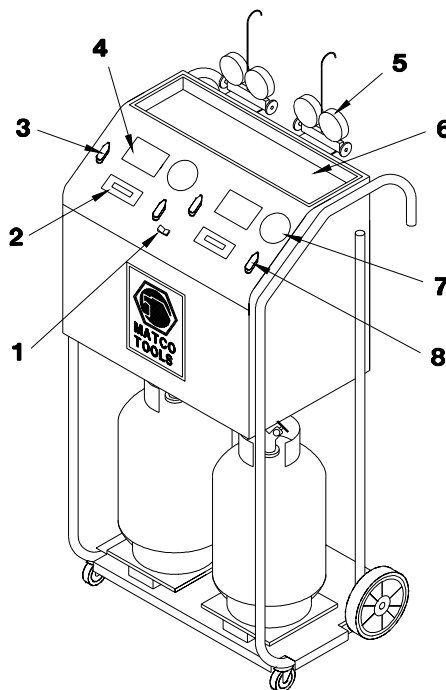

CONTROL PANEL

PURGE CHART - R12

| °F | PSIG | °F | PSIG | °F | PSIG | °F | PSIG |
|----|------|----|------|----|------|-----|------|
| 32 | 44 | 54 | 69 | 76 | 102 | 98 | 143 |
| 34 | 46 | 56 | 72 | 78 | 105 | 100 | 147 |
| 36 | 48 | 58 | 74 | 80 | 108 | 102 | 150 |
| 38 | 50 | 60 | 77 | 82 | 112 | 104 | 155 |
| 40 | 52 | 62 | 80 | 84 | 115 | 106 | 160 |
| 42 | 54 | 64 | 83 | 86 | 118 | 108 | 165 |
| 44 | 57 | 66 | 85 | 88 | 123 | 110 | 168 |
| 46 | 59 | 68 | 88 | 90 | 127 | 112 | 173 |
| 48 | 61 | 70 | 92 | 92 | 130 | 114 | 178 |
| 50 | 64 | 72 | 95 | 94 | 135 | 116 | 183 |
| 52 | 66 | 74 | 98 | 96 | 138 | 118 | 188 |

PURGE CHART - R134a

| °F | PSIG | °F | PSIG | °F | PSIG | °F | PSIG |
|----|------|----|------|----|------|-----|------|
| 32 | 42 | 54 | 70 | 76 | 107 | 98 | 153 |
| 34 | 44 | 56 | 72 | 78 | 110 | 100 | 157 |
| 36 | 46 | 58 | 76 | 80 | 114 | 102 | 163 |
| 38 | 49 | 60 | 78 | 82 | 118 | 104 | 167 |
| 40 | 51 | 62 | 82 | 84 | 123 | 106 | 173 |
| 42 | 54 | 64 | 85 | 86 | 127 | 108 | 180 |
| 44 | 56 | 66 | 88 | 88 | 130 | 110 | 185 |
| 46 | 59 | 68 | 92 | 90 | 135 | 112 | 190 |
| 48 | 61 | 70 | 95 | 92 | 140 | 114 | 195 |
| 50 | 64 | 72 | 97 | 94 | 145 | 116 | 200 |
| 52 | 67 | 74 | 104 | 96 | 148 | 118 | 207 |

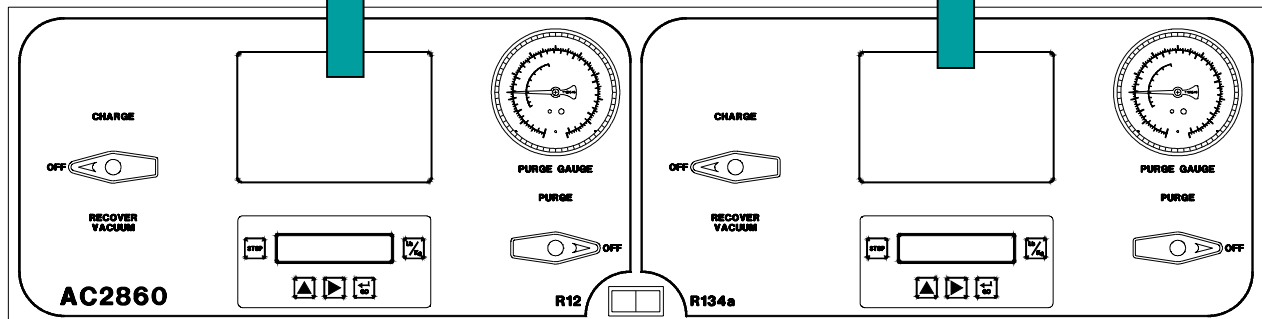

KEYPAD FUNCTIONS

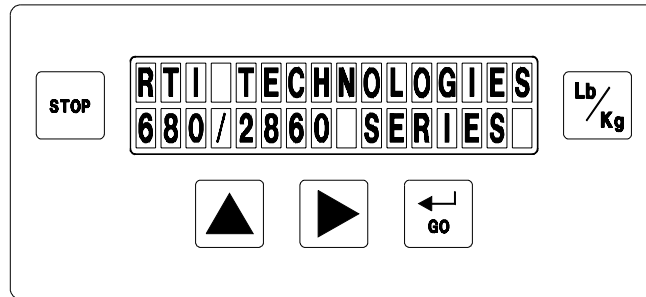

Scroll Key

Press to scroll through function options or to increase numeric values shown on the display.



Cursor Key

Press to move flashing cursor on the display prior to numeric entries.



Go Key

Press to confirm data entry and continue.



Stop Key

Press to halt program sequence.



Units Key

Press to change unit of measure for weight displays.

- CAUTION -

**Always use fingers to operate keypad.
Use of sharp objects will cause damage.**

START-UP

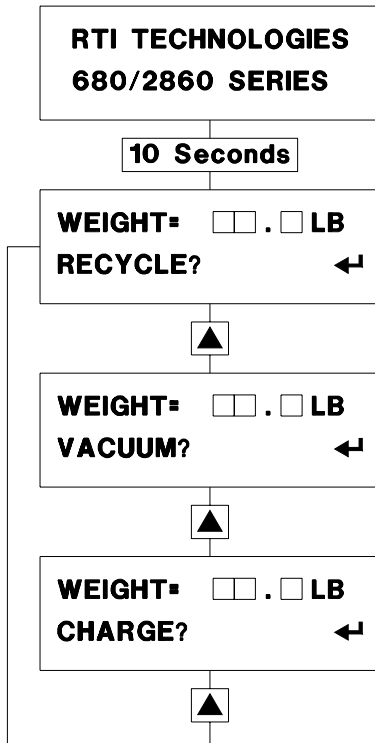

1. Turn Function Valves and Purge Valves on AC2860 to OFF. Connect yellow hoses of gauge manifolds to ports on rear of AC2860. Close high and low valves on gauge manifolds.
2. Connect red and blue hoses from the gauge manifold, for the refrigerant to be processed, to A/C system and open hose valves.
3. Connect power cord of AC2860 to properly grounded power source. Avoid using an extension cord. If necessary use a good condition, three wire grounded, #14 AWG or larger extension cord of the shortest possible length.
4. Select refrigerant to be processed using the R12/R134a Selector Switch. The corresponding display and keypad will be energized.
5. RTI TECHNOLOGIES and 680/2860 SERIES will display for ten seconds.
6. The display will show the weight of refrigerant in the AC2860 cylinder and prompt RECYCLE?
7. Press [←] key to begin a recycle procedure (Page 6) or press [→] key to go to next screen (See next step).
8. The display will show the weight of refrigerant in the charge cylinder and prompt VACUUM?

***** CAUTION *****

Make sure the A/C pressures are at zero or below. If the gauges indicate positive pressure, refrigerant will be vented to the atmosphere. Perform a recover procedure before starting a vacuum procedure.

9. Press [←] key to begin a vacuum procedure (Page 7) or press [→] key to go to next screen (See next step).
10. The display will show the weight of refrigerant in the charge cylinder and prompt CHARGE?
11. Press [←] key to begin a charge procedure (Page 7) or press [→] key to return to Step 6 above.

RECOVER (RECYCLE)

WEIGHT= □□ . □ **LB**
RECYCLING

RECYCLE COMPLETE
CHECK PRESSURES

CYLINDER FULL
GO TO CHARGE

1. Turn Function Valve on AC2860 to RECOVER.
2. Open high and low valves on gauge manifold.
3. The display will show the weight of refrigerant in the AC2860 cylinder and indicate the unit is recycling.
4. When the A/C system pressure is in a vacuum the display will show RECYCLE COMPLETE CHECK PRESSURES. Wait two minutes to see if the pressure in the A/C increases (due to liquid refrigerant vaporizing). The AC2860 will automatically begin recycling again if the pressure rises above zero.
5. Press the stop key and close the high and low valves on the gauge manifold.
6. Turn Function Valve on AC2860 to OFF.

Note:

The display will show CYLINDER FULL GO TO CHARGE if the AC2860 cylinder fills to capacity. Press the STOP key and perform a charge procedure to transfer refrigerant to another A/C system or an external storage cylinder.

PURGE AIR - DRAIN OIL

IMPORTANT: Oil must be drained and Air purged after each recover (recycle) procedure. Failure to do so will cause excess air to be introduced into the A/C during charge and the AC2860 will fill with air causing a high-pressure shutdown.

1. The oil drain valve is accessible from the rear of the AC2860, located under the main enclosure. **Slowly** open the valve and drain any oil into the measuring cup to determine how much oil (if any) should be added to the A/C.
2. Leave the oil drain valve open.
3. Measure the room temperature.
4. Find the corresponding pressure for this temperature on the purge chart printed on the AC2860 top panel.
5. Compare this pressure from the chart with that indicated on the Purge Gauge. If the gauge shows a higher pressure, **slowly** open the Purge Valve a **small** amount until the pressure drops to approximately the pressure shown in the chart.
6. Turn the purge valve to OFF.
7. Close the oil drain valve.

VACUUM

WEIGHT= □□ . □ **LB**
VACUUMING

1. **MAKE SURE THE GAUGE MANIFOLD PRESSURES ARE ZERO OR LESS.** If not, a recover procedure must be performed before starting the vacuum procedure.
2. Turn Function Valve on AC2860 to VACUUM.
3. Open high and low valves on gauge manifold.
4. The display will show the weight of refrigerant in the AC2860 cylinder and indicate the unit is vacuuming.
5. At the end of the desired vacuum time, press the stop key and close the high and low valves on the gauge manifold.
6. Turn Function Valve on AC2860 to OFF.

CHARGE

ENTER CHARGE
AMOUNT= □□ . □ **LB** ←

WEIGHT= □□ . □ **LB**
CHARGING

CHARGE COMPLETE
EVACUATE HOSES

1. Open either the low or high valve on gauge manifold and corresponding hose valve according to the A/C manufacturer's recommendation for charging the system.
2. Enter weight of charge desired using the keypad. Press the [▲] key to increase numeric value shown on display and press [▶] key to move flashing cursor to next position. Press [←] key to start charging.
3. Turn Function Valve on AC2860 to CHARGE.
4. Do not run the A/C during the charge procedure.
5. The display will show the amount of refrigerant being charged into the A/C.
6. The display will show CHARGE COMPLETE EVACUATE HOSES when the correct amount of refrigerant has been charged.
7. Press the stop key and close the hose valve.
8. Turn function valve to OFF.
9. Evacuate the hose by running a recycle procedure.

Note:

The display will show LOW LEVEL GO TO RECYCLE if the AC2860 cylinder does not contain enough refrigerant to complete the charge weight entered. Press the STOP key and perform a recycle procedure to transfer refrigerant into the AC2860 cylinder.

LOW LEVEL. GO TO
RECYCLE

MAINTENANCE

The AC2860 will provide many years of reliable service if properly maintained. Following is a checklist of items which will ensure the AC2860 performs at peak efficiency and presents an image to your customers that your shop performs high tech A/C service.

1. Use tool tray for storage of tools and accessory adapters.
2. Store gauge manifolds and hoses properly when not in use. Avoid hanging hoses over the top of the unit.
3. Keep the exterior surfaces clean. Use a mild all purpose cleaner to wipe oil and dirt off the cabinet.
4. Do not allow the unit to sit outside in direct sunlight or inclement weather. Excessive exposure to sun light and moisture may cause damage and will void the warranty.
5. The AC2860 is not intended to be used for mobile A/C service where the unit is transported to customer sites. Excessive vibration will shorten component life.
6. Be gentle when moving the AC2860 around the shop. Tip the unit and ease the front casters over any obstacles such as door jams, air hoses and floor irregularities.
7. Periodically remove the front cover and check for refrigerant leaks inside the AC2860 using a leak detector. A small leak detected early will prevent future undetected loss of refrigerant.
8. Use regulated, clean shop air to remove debris from the fins of the condenser coil. Be careful and do not disturb any internal components.
9. Periodically check oil level in compressors (oil level sight tubes are on the rear). Oil should be visible in the oil sight tube when the compressor is not operating. If oil is not visible, call RTI Technical Support 800-468-2321.
10. Change filters after every 25 hours of recovery operation. Filters must be changed at least once per year for efficient recycling of refrigerant.

FILTER CHANGE

Filters must be changed after every 25 hours of recycling refrigerant. The display will show "CHANGE FILTERS". This reminder will be displayed whenever the AC2860 is turned on or a new procedure is started.

Turn power off and remove tool tray from top of AC2860 to change filters. Use end wrench to loosen and tighten copper tube fittings. The foam insulation on the smaller outlet filter must be removed from the old filter and installed on the new one. Check for leaks after replacing filters.

After filters have been changed, press and hold the [▶] key and the [▲] key for two seconds to reset the "CHANGE FILTERS" message.

Inlet Filter (long) P/N: 026-80077-00

Outlet Filter (short) P/N: 026-80069-00

PARTS LIST

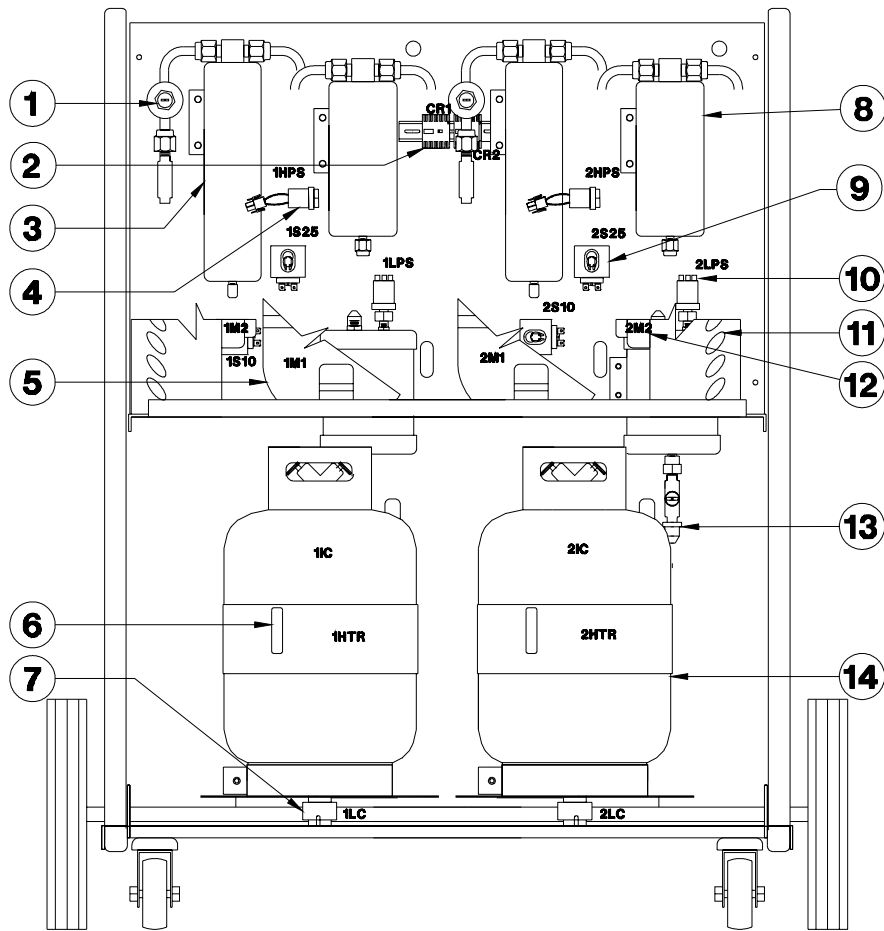

| | P/N | DESCRIPTION |
|---|--------------|----------------------------------|
| 1 | 360-81574-00 | Expansion Valve Assy |
| 2 | 024-80037-00 | Contactors ½ HP 120V 3NC/1NC |
| 3 | 026-80077-00 | Combo Filter 3/8 Flare (Long) |
| 4 | 360-81307-00 | High Pressure Switch 261 psig |
| 5 | 360-81581-01 | Compressor Assy 2860 (120V) |
| 6 | 360-81547-01 | Assy Heater Belt |
| 7 | 031-80000-00 | Load Cell 35Kg |

| | P/N | DESCRIPTION |
|----|--------------|--------------------------------------|
| 8 | 026-80069-00 | Combo Filter 3/8 Flare (Short) |
| 9 | 025-80304-00 | Solenoid Valve 120V |
| 10 | 360-81309-00 | Low Pressure Switch 3psig - 8InHg |
| 11 | 360-80280-00 | Condenser Assy |
| 12 | 360-80416-00 | Fan Assy w/Pins 120V |
| 13 | 360-80851-00 | Oil Drain Assy |
| 14 | 026-80026-00 | Internal Cylinder (DOT) |

PARTS LIST

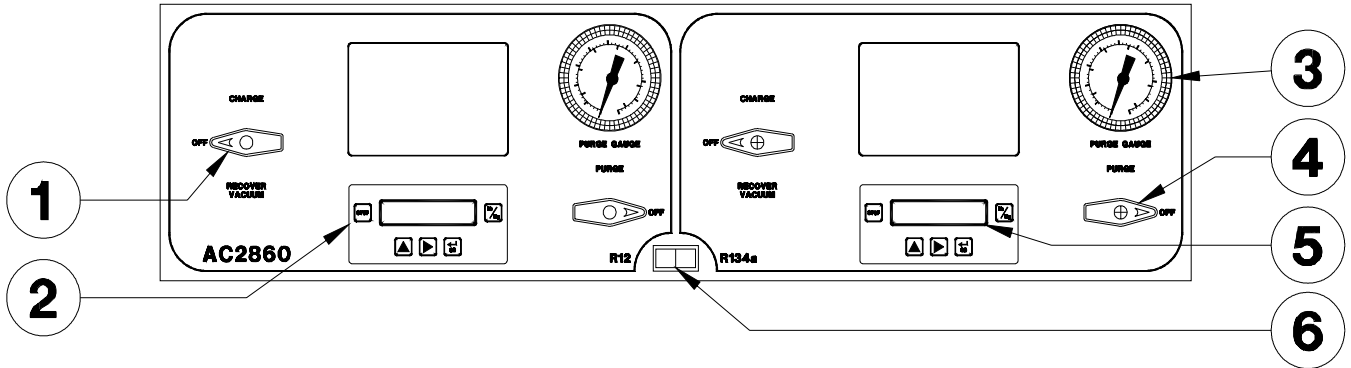

| | P/N | DESCRIPTION |
|---|--------------|-------------------------------------|
| 1 | 360-81577-00 | Main Ball Valve Assy (2860) |
| 2 | 024-80070-00 | Keypad Overlay 680/550/2860 |
| 3 | 026-80071-02 | Purge Gauge Assy 0-500 psig |
| 4 | 360-81576-00 | Purge Ball Valve Assy (2860) |
| 5 | 024-80072-00 | Circuit Board 680/550/2860 |
| 6 | 024-80066-00 | Switch Rocker SPDT (on-on) Visi-Red |