

OPERATION MANUAL

EV-1

EXHAUST VENTILATION SYSTEM



MAHLE

MAHLE AFTERMARKET INC., SERVICE SOLUTIONS

10 Innovation Drive

York, Pennsylvania 17402 USA

717-840-0678 or 800-468-2321

www.servicesolutions.mahle.com

035-81051-00 (REV A)

TABLE OF CONTENTS

ACCEPTANCE OF GOODS.....	2
DESCRIPTION OF GOODS.....	2
SPECIFICATIONS.....	2
GENERAL SAFETY RULES	3
HOW TO PREPARE THE UNIT.....	4
ADDITIONAL INSTRUCTIONS	5
FUSE REPLACEMENT.....	5
CLEANING & MAINTENANCE.....	5
PARTS LIST.....	6
WIRING DIAGRAM	7



WARNING!

READ CAREFULLY EACH SECTION SIGNED WITH THE SYMBOL FOR MACHINE AND UNIT SAFE WORKING CONDITIONS



SUPPLY SYMBOL

DO NOT OPEN, SUPPLY AT 110 VOLTS.

ACCEPTANCE OF THE GOODS

UPON ARRIVAL, IT IS NECESSARY TO CHECK THE QUANTITY COMPLIANCE OF THE EV-1 WITH THE BILL OF LADING OR INVOICE AND PACKING CONDITIONS TO AVOID THE RELEASE WITH DAMAGE WHICH OCCURRED DURING THE TRANSPORT. IF DAMAGE HAS OCCURRED, HAVE THE FORWARDER APPLY A RESERVE ON YOUR DOCUMENTS FOR THE DAMAGES AND CONTACT MAHLE. ONLY BY OBSERVING THESE FEW RULES, WILL IT BE POSSIBLE TO REPAIR OR REPLACE DAMAGED PARTS.

DESCRIPTION OF THE GOODS

THIS EQUIPMENT IS FOR THE VENTILATION OF THE EXHAUST GAS OF CARS AND SMALL TRUCKS. THE UNIT IS EQUIPPED WITH A SLIDING SYSTEM WHICH ALLOWS HEIGHT ADJUSTMENT BETWEEN 8.5 IN. (22 CM) AND 35.5 IN. (90 CM). THIS ADJUSTMENT AUTOMATICALLY LOCKS ONCE THE OPERATOR RELEASES THE ADJUSTMENT LOCK HANDLE. A FURTHER MECHANICAL BRAKING DEVICE IS INSTALLED WHICH, IN CASE OF ADJUSTMENT LOCK FAILURE, DOES NOT PERMIT THE ENTIRE MOTOR UNIT TO DROP COMPLETELY. EXHAUST FUMES ARE DISCHARGED, WITHOUT BEING FILTERED, THROUGH A HEAT RESISTANT HOSE MAX 250° F (125° C).

EXHAUST FUMES DO NOT COME IN CONTACT WITH THE ELECTRIC MOTOR OR OTHER ELECTRICAL COMPONENTS, THUS AVOIDING RISK OF EXPLOSION DUE TO ACCIDENTAL INTAKE OF UNBURNED FUEL OR GAS. THE MACHINE MUST BE USED ONLY FOR THE AFOREMENTIONED PURPOSE. ONLY CORRECT USE OF THE UNIT WILL GRANT A PROFITABLE RESULT. READ THIS OPERATION MANUAL CAREFULLY AND READ IT AGAIN EVERY TIME THERE ARE MACHINE PROBLEMS OR DIFFICULTIES DURING USE.

SPECIFICATIONS	
WIDTH	22 IN. (55 CM)
LENGTH	22 IN. (55 CM)
HEIGHT	40 IN. (100 CM)
WEIGHT	73 LBS. (33 KG)
ELECTRICAL SUPPLY	110 VOLTS
POWER	3/4 HP (0.55 KW)
A-WEIGHTED SURFACE NOISE RATING	CORRECTED LPA = 73 DB (A)
WORKING TEMPERATURE	MINIMUM 23° F (-5° C) MAXIMUM 120° F (49° C)
FUSE (2)	0.39 x 1.49 IN. (10 x 38 MM) 16 AMP TIME DELAYED 500 VAC

GENERAL SAFETY RULES

THE FOLLOWING RULES MUST BE STRICTLY FOLLOWED TO AVOID ANY UNIT DAMAGE OR OPERATOR RISK:

READ THE LABELS ON THE EV-1. NEVER COVER THE LABELS. REPLACE THEM IF DAMAGED

THE EV-1 MUST BE USED BY AUTHORIZED AND SKILLED PERSONNEL ONLY

LOCK THE WHEELS BEFORE USING THE EV-1

KEEP AWAY FROM CHILDREN AND NON-AUTHORIZED PERSONNEL DURING USE

DO NOT PUT CONTAINERS ON THE EV-1

WORKING TEMPERATURE SHOULD BE BETWEEN 230 F (-5° C) AND 120° F (49° C)

HUMIDITY SHOULD BE LESS THAN 95 PERCENT

DO NOT USE THE UNIT IN AN EXPLOSIVE ENVIRONMENT

DO NOT USE GASOLINE OR SOLVENTS THAT COULD CATCH FIRE

DO NOT USE ACID SOLUTION THAT COULD DAMAGE THE EV-1 OR PERSONNEL

DO NOT CRASH INTO SHELVES OR FRAMEWORKS TO AVOID OBJECTS FALLING

IN CASE OF MALFUNCTIONING OF THE EV-1, CONTACT MAHLE.

USE ONLY MAHLE REPLACEMENT PARTS

HOW TO PREPARE THE UNIT

ASSEMBLY OF THE MOUTHPIECE

ATTACH THE MOUTHPIECE AS SHOWN IN THE PICTURE AND FASTEN IT WITH THE PROVIDED SCREWS.



MOUNTING OF THE HOSE

ATTACH THE HOSE AND SECURE IT WITH THE CLAMP

PUT THE END OF THE EXHAUST HOSE OUTSIDE. CONNECT THE ELECTRICAL PLUG TO THE NEAREST OUTLET. THE EV-1 IS NOW READY TO OPERATE.

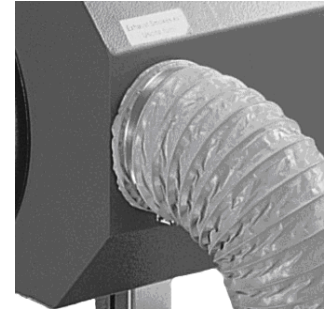

ATTENTION!

TO USE THE EV-1 CORRECTLY, YOU MUST HAVE AN UPSTREAM DIFFERENTIAL PROTECTION SYSTEM OF 30 AMP.

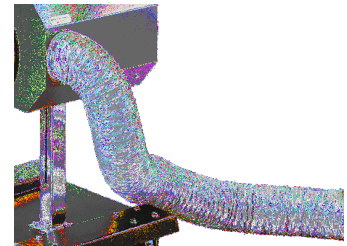

ADJUST THE HEIGHT OF THE EV-1 TO PLACE THE SUCTION MOUTHPIECE AS CLOSE AS POSSIBLE TO THE EXHAUST PIPE. LOCK THE WHEELS OF THE UNIT. TURN ON THE EV-1 AND THEN START THE ENGINE.



ATTENTION!

DO NOT SUCK UP PLASTIC BAGS, PAPER, ETC. THEY COULD CLOSE THE GRILL AND IMPEDE THE EXHAUSTING OF THE EXHAUST GAS.

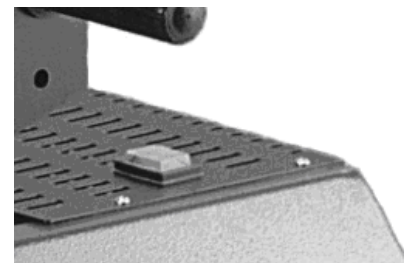

ADDITIONAL INSTRUCTIONS

MOUNTING OF THE ADDITIONAL KIT

REMOVE POWER FROM THE EV-1 BEFORE REMOVING THE MOUTHPIECE; SUBSTITUTE THIS PART WITH THE TWO-WAY PIPE.



ATTENTION!

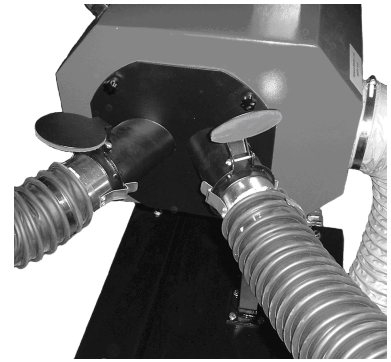

REMOVE POWER FROM THE EV-1 BEFORE REMOVING THE PROTECTION GRILL. THE MANUFACTURER DISCLAIMS RESPONSIBILITY FOR DAMAGE TO PEOPLE OR OBJECTS.



LIFT THE COVER AND CONNECT THE HOSES.

TO USE ONLY ONE HOSE, TAKE AWAY THE SECOND HOSE AND CLOSE THE COVER.

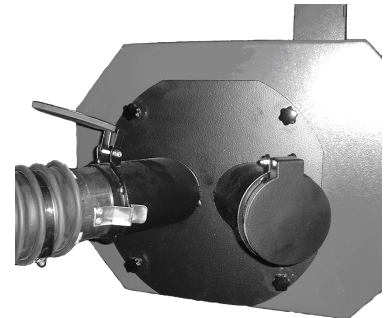

FUSE REPLACEMENT

DISCONNECT EV-1 FROM POWER. UNSCREW THE PROTECTION GRILL AND REPLACE THE FUSES. REFER TO THE SPECIFICATIONS FOR THE FUSE SIZE. MOUNT THE GRILL AND FIX IT WITH SCREWS.



ATTENTION!

REMOVE POWER FROM THE EV-1 BEFORE REMOVING THE PROTECTION GRILL. THE MANUFACTURER DISCLAIMS RESPONSIBILITY FOR DAMAGE TO PEOPLE OR OBJECTS.

CLEANING AND MAINTENANCE

THE EV-1 DOES NOT REQUIRE ANY SPECIAL MAINTENANCE, ONLY NORMAL CLEANING, WHICH SHOULD BE DONE WITH A DAMP CLOTH (WATER AND ALCOHOL OR NORMAL HOUSEHOLD DETERGENT).



ATTENTION!

THE MACHINE MUST NOT BE CLEANED WITH NITROCELLULOSE BASED SOLVENTS.

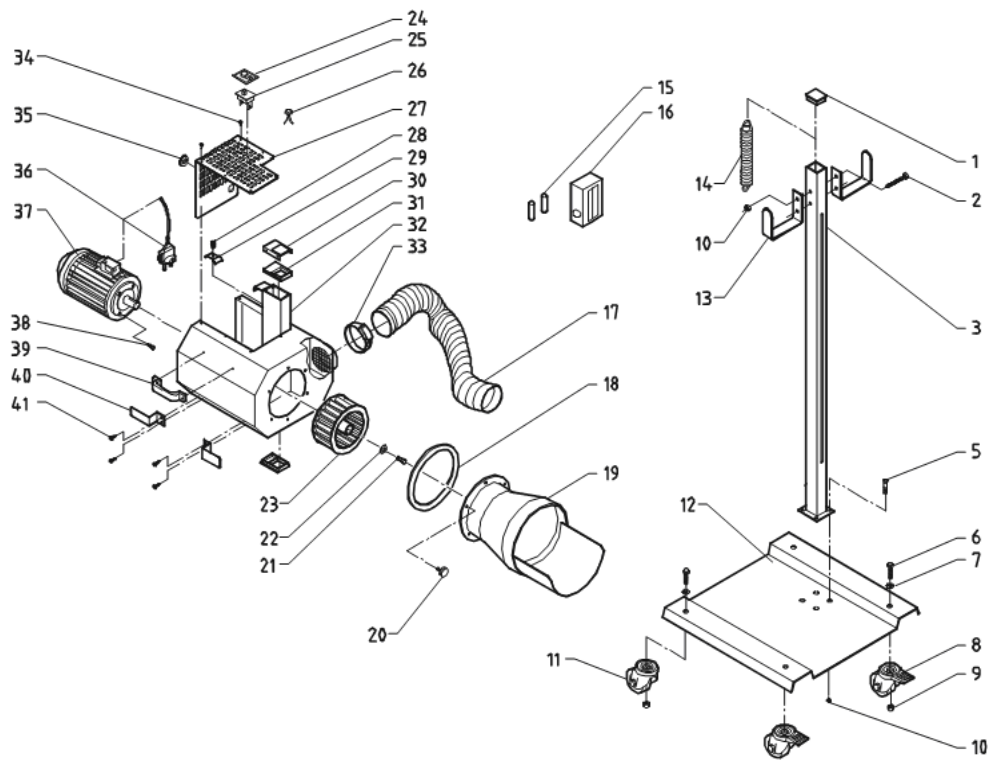

#	QTY	DESCRIPTION	PART No.		QTY	DESCRIPTION	PART No.
01	1	PLUG	035-88001-00	22	1	WASHER	035-88022-00
02	4	SCREW	035-88002-00	23	1	FAN	035-88023-00
03	1	COLUMN	035-88003-00	24	1	LEVER	035-88024-00
				25	1	SWITCH	035-88025-00
05	4	SCREW	035-88005-00	26	1	LIGHT	035-88026-00
06	4	SCREW	035-88006-00	27	1	GRILL	035-88027-00
07	4	WASHER	035-88007-00	28	1	SPRING	035-88028-00
08	2	WHEEL WITH BRAKE	035-88008-00	29	1	HANDLE	035-88029-00
09	4	NUT	035-88009-00	30	1	LOCKER	035-88030-00
10	5	NUT	035-88010-00	31	2	SLIDE	035-88031-00
11	1	WHEEL	035-88011-00	32	1	FRAME	035-88032-00
12	1	BASE	035-88012-00	33	1	CLAMP	035-88033-00
13	2	HOSE HOOK	035-88013-00	34	14	SCREW	035-88034-00
14	1	SPRING	035-88014-00	35	1	CLAMP	035-88035-00
15	2	FUSE (16 AMP)	035-88015-00	36	1	CABLE	035-88036-00
16	1	FUSE HOLDER	035-88016-00	37	1	MOTOR	035-88037-00
17	1	HOSE	035-88017-00	38	4	SCREW	035-88038-00
18	1	GASKET	035-88018-00	39	1	HANDLE	035-88039-00
19	1	MOUTH	035-88019-00	40	2	POWER CORD HOOK	035-88040-00
20	4	HAND WHEEL	035-88020-00	41	2	SCREW	035-88041-00
21	1	SCREW	035-88021-00				

	QTY	DESCRIPTION	PART NO.
1	1	GASKET	035-88042-00
2	1	FLANGE	035-88043-00
3	2	CLOSING SYSTEM	035-88044-00
4	2	HOSE WITH SPRINGS	035-88045-00
5	2	GASKET	035-88046-00
6	2	SCREW	035-88047-00
7	2	NUT	035-88048-00
8	4	CLAMP	035-88049-00
9	4	HAND WHEEL	035-88050-00
10	2	CONNECTION HOSE	035-88051-00

