

MAHLE CBD-200

EN

Operation Manual
Disc Brake Dolly

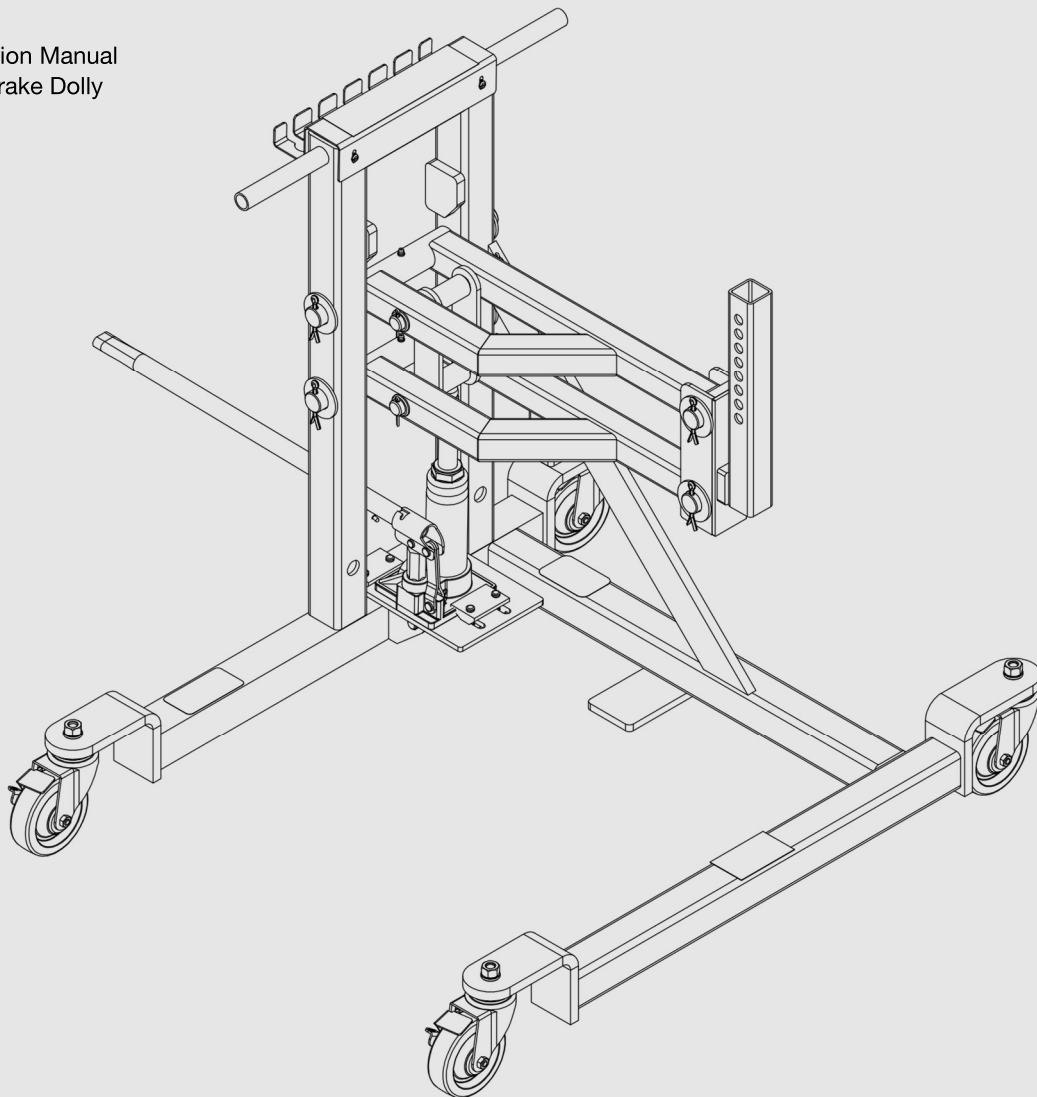



**EVERY PERSON WHO OPERATES THIS
EQUIPMENT NEEDS TO KNOW AND
UNDERSTAND ALL OF THE INFORMATION IN
THIS MANUAL – FAILURE TO DO SO COULD
RESULT IN SERIOUS INJURY OR DEATH.**

**READ THIS MANUAL
CAREFULLY AND
RETAIN FOR YOUR
RECORDS**

Contents

1. Safety Regulations	4
1.1 Warnings.....	Error! Bookmark not defined.
2. Foreword.....	5
2.1 From the manufacturer	5
3. Symbols Use	5
3.1 Signal words	5
4. Responsibilities	6
4.1 Receiving inspection	6
4.2 Owner and/or operator responsibilities	6
5. Specifications	6
6. Product Description	7
6.1 Component identification	7
7. Operation	8
7.1 Removing a Caliper	8
7.2 Replacing a Caliper	8
7.3 Removing a Rotor/Wheel End Assembly, Rotor Adapter	8
7.4 Removing a Rotor/Wheel End Assembly, Wheel End Adapter	9
7.5 Replacing a Rotor/Wheel End Assembly.....	10
7.6 Removing a Brake Drum, Brake Drum Adapter.....	10
7.7 Replacing a Brake Drum	11
8. Maintenance Instructions	12
8.1 Structural Inspection	12
10. Troubleshooting	13
11. Notes	Error! Bookmark not defined.

1. Safety Regulations

1.1 Warnings

To avoid serious injury or death, read this manual carefully before operating this Disc Brake Dolly.

Failure to understand and obey safety instructions may result in unsafe or improper use of this product.

- ⚠ Maximum capacity of the CBD-200 is 200 lb. / 90 kg. The adapters have individual capacities which reduce the overall capacity of the CBD-200 to that of the adapter or attachment. Do not overload.
- ⚠ Use this Disc Brake Dolly only on hard level surfaces capable of sustaining the load. Use on other than hard level surfaces can result in Disc Brake Dolly instability and possible loss of load.
- ⚠ This Disc Brake Dolly is designed solely for the removal and installation of Calipers, Rotor/Hub Assemblies, and Wheel End Components on highway trucks, trailers, tractors, and buses.
- ⚠ No alterations shall be made to this product.
- ⚠ Adapters designed specifically for the Disc Brake Dolly are the only approved lifting points. Do not attempt to use any other part of the Disc Brake Dolly as a lifting point. Place caliper as close to the center of Disc Brake Dolly as possible.
- ⚠ Do not use any kind of cribbing or adapters with this Disc Brake Dolly. The Disc Brake Dolly must remain in direct contact with the floor and the adapter must be in direct contact with the component to be lifted.
- ⚠ After raising a vehicle, never allow any part of your body to pass under it and never begin work on the vehicle until it is properly supported by adequate vehicle support stands. Once the vehicle is properly supported and is stable the Disc Brake Dolly can then be positioned to install or remove calipers and rotor/hub assemblies.
- ⚠ Lower and secure load before moving Disc Brake Dolly to another area.
- ⚠ Never place hand or any other body part between the Disc Brake Dolly and component that is being lifted, personal injury can occur.
- ⚠ If the Disc Brake Dolly does not have enough capacity to raise the caliper or rotor/hub assembly, remove it and use a Disc Brake Dolly with adequate capacity. Failure to observe this

instruction may lead to unstable or overload conditions that could cause failure of the Disc Brake Dolly.

Failure to understand and obey these warnings may result in personal injury and / or property damage.

2. Foreword

2.1 From the manufacturer

Thank you for your purchase. To complement the offering of A/C, fluid and nitrogen service equipment, MAHLE Service Solutions has partnered with Gray Manufacturing to provide the highest quality hydraulic and pneumatic equipment available for the professional service technician. This equipment adheres to high standards promised in the MAHLE guarantee including the assurance of innovation and reliability that comes with the Gray Manufacturing name. Please contact MAHLE Service Solutions' customer service at (800) 468-2321 or tech.mss@us.mahle.com with any comments or questions.

3. Symbols Use

3.1 Signal words

Signal words call attention to a safety message or messages, or a property damage message or messages, and designate a degree or level of hazard seriousness. Signal words used in this manual include:

Keyword	Probability of occurrence	Severity of danger if instructions not observed
DANGER	Immediate impending danger	Death or severe injury.
WARNING	Possible impending danger	Death or severe injury
CAUTION	Possible dangerous situation	Minor injury
NOTICE	Possible damage to property	Possible property damage

4. Responsibilities

4.1 Receiving inspection

Before attempting to operate this equipment, thoroughly read and understand this manual. Completely remove all tape and packaging. Inspect the equipment immediately upon delivery. If shipping damage is evident, inform the delivering carrier immediately and contact the manufacturer using the contact information on the back cover of this manual.

4.2 Owner and/or operator responsibilities

The owner of this equipment must read these instructions and maintain them for future reference and for instructing any other users of the equipment. The owner is responsible for keeping all warning labels and instruction manuals legible and intact. Replacement labels and literature are available from the manufacturer. The owner must never authorize or allow anyone to use this equipment until the operator has read and understood the information in this manual and on the accompanying labeling on the equipment itself.

If this equipment is being used in an occupational setting (or workplace), the employer should ensure that all personnel working with and around the equipment know of the risks associated with its use. Personnel involved in the use and operation of this equipment shall be careful, competent, trained, and qualified in the safe operation of the equipment and its proper use when servicing motor vehicles and their components. Safety information provided with this equipment should be emphasized by the employer and understood by each employee. The employer must make this manual available to all personnel using this equipment and all personnel must read and understand the contents of this manual. If the operator is not fluent in English, the manufacturer's instructions and warnings shall be read to and discussed with the operator in the operator's native language by the employer, making sure that the operator comprehends its contents and observes the proper procedures for use of this equipment.

5. Specifications

Model CBD-200	US units	Metric units
Maximum capacity	200 lbs	90 kg
Overall width	36 in	91.4 cm
Overall length	29 ¼ in	74.3 cm
Start Height	15 -16 in	38.1 cm – 40.6 cm
Raised Height	38 - 42 in	96.5 cm - 106.7 cm
Weight	205 lb	93 kg

6. Product Description

6.1 Component identification

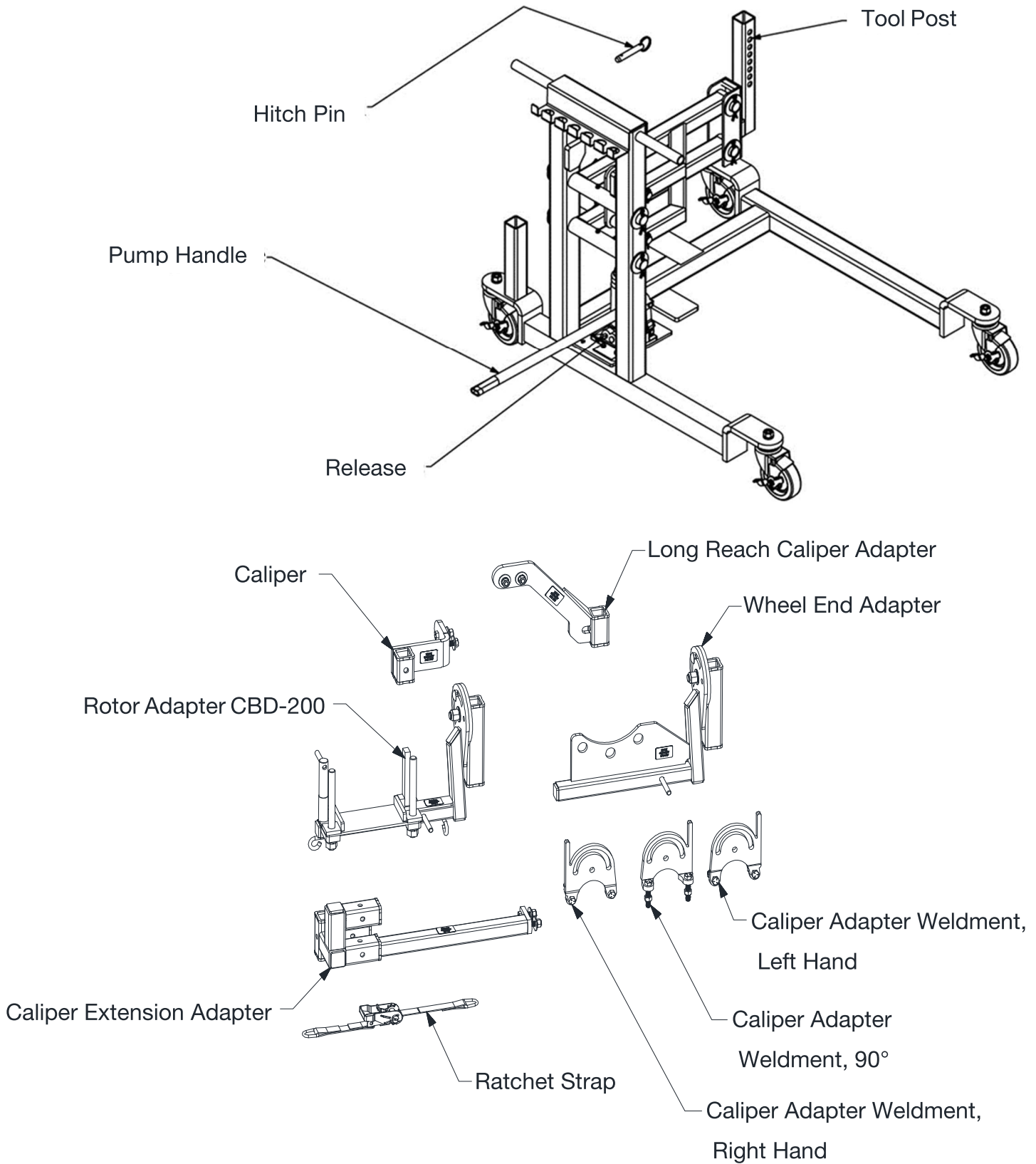

7. Operation

WARNING - This section discusses the appropriate and safe methods for using the stand. Failure to follow all of the steps outlined in this section could result in serious injury or death.

Before using the CBD-200 operator needs to understand how the CBD-200 works. There is one lifting means available to the operator, which is the manual hydraulic power unit. It is used to elevate and lower vertical position. The release valve should be closed while using the hydraulic power unit to lift. If the carriage is elevated, it can be easily lowered using the hydraulic release. The Disc Brake Dolly swivel casters can be locked to prevent further rolling.

7.1 Removing a Caliper

1. Park vehicle on level surface to raise the vehicle. Raise the vehicle high enough to get the wheel off the ground. Support the vehicle with adequate vehicle support stands before removing any components or getting under the vehicle. Chock wheels to prevent the vehicle from moving.
2. Remove tire and wheel assembly to access wheel hub and caliper according to the manufacturer's instructions using a supporting device or wheel dolly.
3. Release air brakes and install the brake chamber release tool/cage bolt per manufacturer's instructions. Once caged, remove the mounting nuts or bolts and detach the chamber from the caliper. Do Not Attempt to remove the brake chamber without caging them according to the manufacturer's instructions.
4. Select the caliper adapter tool supplied with the Disc Brake Dolly that will fit the caliper configuration and that best suits the caliper being removed. Attach the adapter on the Disc Brake Dolly where the center of gravity of the caliper will be as close to the tool post as possible.
5. Using the manual power unit, raise the disc brake dolly high enough so that the caliper adapter can be positioned to where the studs on the caliper adapter can be inserted into the brake chamber mounting holes on the caliper. Tighten angle adjustment nuts on the caliper adapter once the desired angle has been determined.

6. Insert the studs on the adapter into the brake chamber mounting holes. Install nuts (provided) onto the studs to secure the caliper to the caliper adapter. Disconnect any ABS or any other brake sensors that may be connected to the caliper.
7. Remove the caliper mounting bolts from the brake spider. Once the caliper is free, raise or lower the caliper using the manual power unit on the Disc Brake Dolly. It may be necessary to use a dead blow hammer or a prying tool to free the brake caliper from the brake spider.
8. If replacing the caliper, remove the nuts on the caliper adapter and remove old caliper. Do not readjust the angle of the adapter. Place new caliper onto the Disc Brake Dolly.

7.2 Replacing a Caliper

1. Reinstall the caliper by following the removal instructions in the reverse order, and the manufacturer's installation instructions.
2. Torque all fasteners according to the manufacturer's instructions.
3. Adjust brakes per manufacturer's instructions once caliper and brake chamber are reassembled.
4. Raise vehicle, remove stands, lower vehicle, and remove wheel chocks.
5. Test brakes on vehicle and make sure all repairs or maintenance have been completed according to the manufacturer's specifications

7.3 Removing a Rotor/Wheel End Assembly, Rotor Adapter

1. It will be necessary to remove the caliper in order to remove the rotor. Follow the instructions for removing the caliper. Remove caliper and caliper adapter from the Disc Brake Dolly and install the rotor adapter to the tool post and fully insert the pin to the tool post at the desired height. Using the second pin, pin the rotor adapter to the horizontal position.
2. Once caliper and pads have been detached, remove the hub cap.
3. Remove keeper arm or spindle nut retaining device.

4. Using a wheel nut socket and wrench, loosen spindle nut, but do not remove.
5. Adjust the width of the rotor adapter adjustable retaining pins; (shown in figure 1) to accept the rotor into the adapter and tighten the nuts on the bottom of the rotor adapter once the correct width is determined.

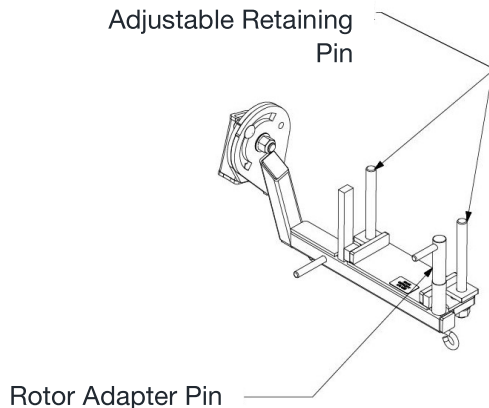

Figure 1

6. Position the Disc Brake Dolly with Rotor Adapter under rotor/wheel end assembly. It may be necessary to remove the rotor adapter pin (shown in Figure 1) on the adapter to position the Disc Brake Dolly under the rotor and hub assembly. Close release on the manual power unit. Once under the rotor, raise the Disc Brake Dolly with the manual power unit until it contacts the rotor and hub assembly. Replace the rotor retaining pin in the socket tube on the rotor adapter.
7. Attach both ends of the ratchet strap to the hooks on the rotor adapter. Operate the ratchet until the strap is tight enough to secure rotor/wheel end assembly to the rotor adapter.
8. Remove the spindle nut, washer, and outer spindle bearing. Move rotor/wheel end assembly side to side gently to free it from the spindle. As the rotor/wheel end assembly becomes free, roll the Disc Brake Dolly away from the vehicle.
9. The rotor adapter horizontal positioning pin may be removed so that the rotor adapter can be rotated in order to service the rotor/wheel end assembly. The rotor adapter has a feature that allows the adapter to be adjusted to where it can be rotated and by friction can stay in the position until moved by the operator. To adjust this feature,

tighten or loosen the nut on the carriage bolt on the back of the rotor adapter.

7.4 Removing a Rotor/Wheel End Assembly, Wheel End Adapter

1. It will be necessary to remove the caliper in order to remove the rotor. Follow the instructions for removing the caliper. Remove caliper and caliper adapter from the Disc Brake Dolly, install the Wheel End Adapter to the tool post, and fully insert the pin to the tool post at the desired height. Using the second pin, pin the Wheel End Adapter to the horizontal position.
2. Once caliper and pads have been detached, remove the hub cap.
3. Remove keeper arm or spindle nut retaining device.
4. Using a wheel nut socket and wrench, loosen spindle nut, but do not remove.

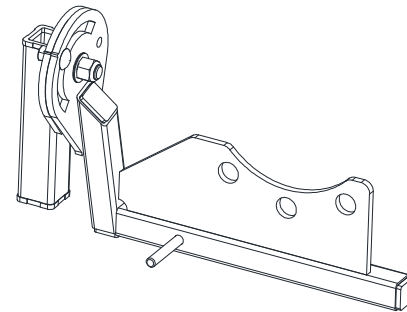

Figure 2

5. Position the Disc Brake Dolly with Wheel End Adapter in front of wheel end assembly. Rotate the wheel end to align the wheel studs to the mounting holes on the Wheel End Adapter. Rotate Wheel End Adapter as needed to mount the wheel end to the hub. Tighten three wheel-nuts to attach the wheel end to the Wheel End Adapter.
6. Remove the spindle nut, washer, and outer spindle bearing. Move rotor/wheel end assembly side to side gently to free it from the spindle. As the rotor/wheel end assembly becomes free, roll the Disc Brake Dolly away from the vehicle.
7. The Wheel End Adapter horizontal positioning pin may be removed so that the Wheel End Adapter can be rotated in order to service the rotor/wheel end assembly. The Wheel End Adapter has a

feature that allows the adapter to be adjusted to where it can be rotated and by friction can stay in the position until moved by the operator. To adjust this feature, tighten or loosen the nut on the carriage bolt on the back of the Wheel End Adapter.

7.5 Replacing a Rotor/Wheel End Assembly

1. After performing all required repairs and maintenance procedures according to the manufacturer's instructions, the rotor hub assembly can be reinstalled.
2. Rotate Rotor Adapter or Wheel End Adapter to the horizontal position and pin into place.
3. Move the Disc Brake Dolly close to the spindle and adjust the height of the rotor/wheel end assembly with the manual power unit. Align and gently assemble rotor/wheel end assembly onto the spindle taking care not to damage to seals and bearing journals.
4. Install outer bearing into the bearing journal in the wheel end as instructed by the manufacturer's specifications.
5. Install the spindle washer and nut and hand tighten it.
6. Lower the Disc Brake Dolly and if needed remove the retaining pin from the socket tube to allow the Disc Brake Dolly to be moved away and stored out of the way of the work area.
7. Torque the wheel nut according to the manufacturer's specifications and install the wheel nut retainer.
8. Install the wheel end cap according to the manufacturer's specifications.
9. Install the tire wheel assembly according to the manufacturer's instructions.

7.6 Removing a Brake Drum, Brake Drum Adapter

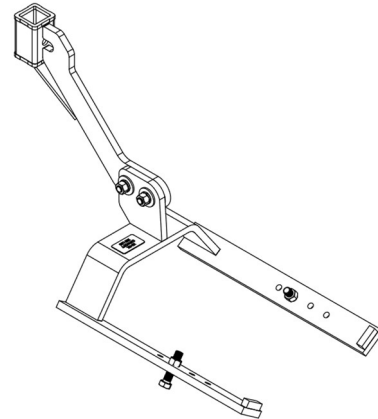

1. Park vehicle on level surface to raise the vehicle. Raise the vehicle high enough to get the wheel off the ground. Support the vehicle with adequate vehicle support stands before removing any components or before getting under the vehicle. Chock wheels to prevent the vehicle from moving.
2. Remove tire and wheel assembly to access brake drum according to the manufacturer's instructions using a supporting device or wheel dolly.
3. Release air brakes and install the brake chamber release tool/cage bolt per manufacturer's instructions. Do Not Attempt to remove the brake drum without caging the brakes according to the manufacturer's instructions.
4. Attach the Brake Drum Adapter to the tool post on the Disc Brake Dolly in the direction shown and fully insert the hitch pin in the top position of the tool post. Pinning in the lower positions could cause brake drum to contact CBD-200 frame. The Brake Drum Adapter should only be attached in the direction shown.

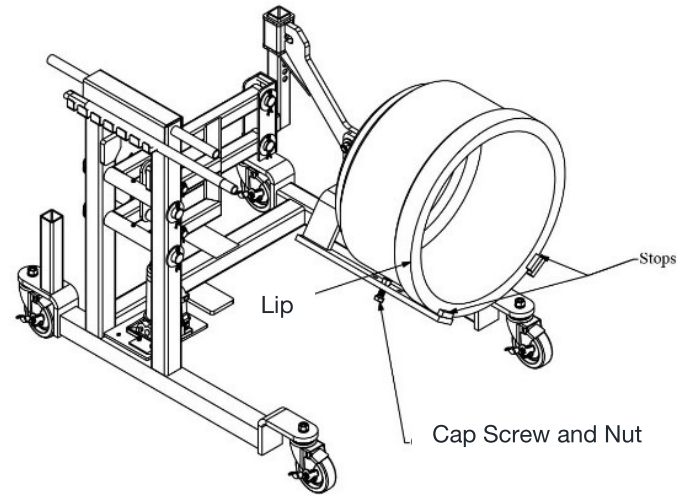
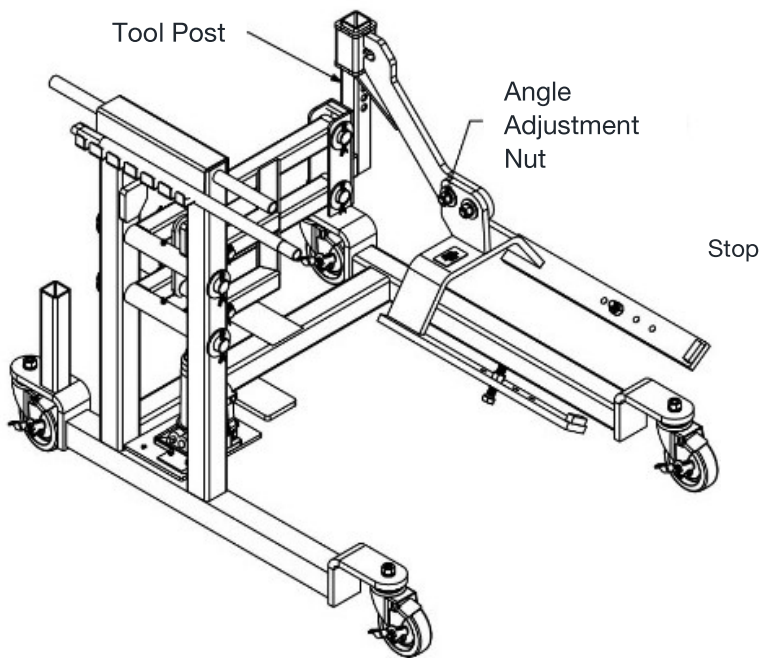

5. Using the manual power unit, raise the disc brake dolly high enough so that the Brake Drum Adapter can be positioned under the brake drum. Tighten mounting nut and angle adjustment nut on the Brake Drum Adapter once the desired angle has been determined. Adjust the cap screws the desired position and height for the brake drum to sit horizontally on the Brake Drum Adapter and lock into place by tightening the nut.
6. Roll the CBD-200 into position and raise the Brake Drum Adapter until it becomes in contact with the brake drum on the vehicle and lock the casters. The Brake Drum Adapter must be inserted far enough under the brake drum, such that the stops engage the lip of the brake drum as shown below. The brake drum may need to be broken loose from the wheel end due to corrosion or oxidation. It may be necessary to use a dead blow hammer or a prying tool to free the brake drum from the wheel end.

7. Once the brake drum is free, unlock the casters and carefully move the CBD-200 away from the vehicle with the brake drum resting on the Brake Drum Adapter. The Drum can be lowered to the floor by using the release on the manual power unit.

7.7 Replacing a Brake Drum

1. Reinstall the brake drum by following the removal instructions in the reverse order, and the manufacturer's installation instructions.
2. Torque all fasteners according to the manufacturer's instructions.
3. Uncage Brake Canister and adjust brakes per manufacturer's instructions once brake drum reassembled.
4. Raise vehicle, remove stands, lower vehicle, and remove wheel chocks.
5. Test brakes on vehicle and make sure all repairs or maintenance have been completed according to the manufacturer's specifications.

8. Maintenance Instructions

WARNING

All inspection and maintenance procedures must be performed after the Disc Brake Dolly has been removed from service. Failure to heed this warning may result in personal and / or property damage.

NOTICE

The owner must inspect or appoint a knowledgeable person to inspect the Disc Brake Dolly. Visual inspection should be made before each use of Disc Brake Dolly, checking for abnormal conditions. Regular inspections should be made weekly for daily use and monthly for intermittent use. Each Disc Brake Dolly must be inspected immediately if subjected to an abnormal load or shock. Any Disc Brake Dolly which appears to be damaged in any way, is found to be badly worn, or operates abnormally shall be removed from service until necessary repairs are made.

1. Check oil level in the oil reservoir. Refer to the "Adding Hydraulic Fluid" section.
2. All warning and capacity labels should be readable and complete. Wash external surfaces of jack, labels, and decals with a mild soap solution.
3. Lubricate all rotating and sliding portions of the jack monthly.
4. Grease the jack once per month with good bearing grease. There are grease fittings located in the pivot tubes of the lift arm, and casters.

intermittent use. Each Disc Brake Dolly must be inspected immediately if subjected to an abnormal load or shock. Any Disc Brake Dolly which appears to be damaged in any way, is found to be badly worn, or operates abnormally shall be removed from service until necessary repairs are made

1. Visually inspect each Disc Brake Dolly component, for signs of cracking, chipping, or excessive wear, including all welds.
2. Visually inspect the lift carriage for any permanent deformation such as bending or twisting. The lift carriage should raise and lower smoothly. If the lift carriage is not able to be raised to full height or does not stay in fully raised position, refer to the Adding Hydraulic Fluid section of this manual.
3. Visually inspect the power unit for oil leaks. Refer to the Troubleshooting section if oil leaks are present.
4. Visually inspect all four wheels for cracking, chipping or excessive wear. The wheels should rotate freely.
5. Visually inspect the entire Disc Brake Dolly and adapters for leaks, cracks and loose connections or loose or missing fasteners. All controls should operate freely.

If any irregularities or problems are detected during an inspection, the Disc Brake Dolly must be removed from service immediately and repaired. Contact the Manufacturer at the numbers and address printed on the back cover of this manual.

8.1 Structural Inspection

WARNING

The Disc Brake Dolly must be removed from service and inspected for damage immediately if the Disc Brake Dolly is subjected to an abnormal shock or load. Failure to heed this warning may result in personal and / or property damage.

NOTICE

The owner must inspect or appoint a knowledgeable person to inspect the Disc Brake Dolly for signs of corrosion and / or excessive wear. Visual inspection should be made before each use of the Disc Brake Dolly, checking for abnormal conditions. Regular inspections should be made weekly for daily use and monthly for

9. Adding Hydraulic Fluid

1. Remove the Disc Brake Dolly from service.
2. The lift arms must be in the fully lowered position and the Disc Brake Dolly must be on a level surface.
3. Clean the side of the reservoir before removing the plug to prevent contamination of the hydraulic oil and hydraulic system.
4. Remove the plug. Visually check the hydraulic oil level. The oil should be visible and within half inch of the fill hole. If the fluid level is low, add a high-grade hydraulic fluid equivalent to Tellus T22.

CAUTION

Do not use brake or transmission fluid. Use of the wrong fluid can deteriorate the seals and corrosion problems will occur.

5. Re-install the plug. Clean up any spilled oil. Test the Disc Brake Dolly for normal operation.

If the lift carriage still doesn't rise to proper height, repeat steps above. If this doesn't solve the problem, contact customer service at the numbers and address printed on the back cover of this manual.

10. Troubleshooting

This is a list of problems and solutions. If the solution listed fails to correct the problem, contact customer service at the numbers and address printed on the back cover of this manual. Please have the model number, and serial number of your Disc Brake Dolly available. The serial number is located on one of the rear caster brackets.

Problem	Cause/Solution
Fails to lift load	<ul style="list-style-type: none"> • Low oil level, see the "Adding Hydraulic Fluid" section • Release open, turn release control knob clockwise until tight. • Overloaded, use larger capacity Disc Brake Dolly.
Fails to hold load	<ul style="list-style-type: none"> • Release open, turn release control knob clockwise until tight.
Oil leaks	<ul style="list-style-type: none"> • Reservoir plug loose, tighten plug. • Reservoir is overfilled. Oil will leak from the plug if reservoir is overfilled.

11. Notes

MAHLE

MAHLE Aftermarket Inc.
916A West State Street
St. Johns, Michigan 48879-1401 U.S.A.

Phone: (800) 468-2321
E-mail: tech.mss@us.mahle.com

www.servicesolutions.mahle.com

670-90825_D