

MAHLE ACX1180C

EN

Operation Manual
A/C Service Units



Contents

1. Symbols use	4	4. Commissioning	15
1.1 In the documentation	4	4.1 Removing transportation packaging	15
1.1.1 Warning notices—Structure and meaning	4	4.2 Attaching handle	15
1.1.2 Symbols in this documentation	4	4.3 Attaching Temperature Probes	15
1.2 On the product	4	4.4 ACX1180C	16
		4.4.1 Setting language	16
		4.4.2 Setting date and time	16
		4.4.3 Activating / deactivating printer, buzzer	16
2. Important notes	4	4.5 Setup	16
2.1 User group	4	4.5.1 Selectable Options	16
2.2 Agreement	4	4.5.2 Default Values	17
2.3 Obligation of contractor	5	4.5.3 Maintenance Options	17
2.4 Safety regulations	6	4.5.4 Total Capacities	17
2.4.1 ACX1180C	6	4.6 Checking type of connection of	
2.4.2 Refrigerant identification unit	7	external refrigerant bottle	17
2.5 Safety devices	7	4.7 Filling internal refrigerant bottle	18
3. Product description	8	5. A/C service preparation	19
3.1 Application	8		
3.2 Scope of delivery	8	6. Operation	20
3.3 Description of unit	9	6.1 Service phases	20
3.3.1 Selection and function keys	10	6.2 A/C Database	20
3.3.2 Input keys	10	6.3 Refrigerant identification unit	20
3.3.3 Printer (Optional)	11	6.3.1 Refrigerant analysis	20
3.3.4 Service doors	11	6.4 Automatic A/C service	21
3.3.5 Oil bottles	12	6.5 Manual A/C service	21
3.3.6 Service quick-release couplings	12	6.6 Automatic/manual vehicle A/C	
3.3.7 Inline filters	13	service overview	22
3.3.8 Locking caster brakes	13	6.6.1 Recovery	22
3.3.9 Power supply cable and switch	13	6.6.2 Vacuum	22
3.4 Refrigerant identification unit (Optional)	13	6.6.3 Charging with refrigerant	22
3.4.1 Delivery	13	6.7 Flushing after changing type of oil	22
3.5 Functional description	14	6.8 Setting service parameters	22
		6.9 Non-condensable gases	22
		6.10 A/C System Test Mode	23
		6.11 High Pressure Leak Detect	23
		6.12 Refrigerant Flush	23

7.	Maintenance	24
7.1	Maintenance interval	24
7.2	Calibration of refrigerant scale	24
7.3	Calibration check	24
7.4	Replacing inline filters	24
7.5	Vacuum pump	25
	7.5.1 Changing vacuum pump oil	25
7.6	Combo filter	26
	7.6.1 Changing Combo-Filter	26
	7.6.2 Resetting filter replacement interval	26
7.7	Software update	27
7.8	Replacing printer paper	27
7.9	Replacing white sample filter (Refrigerant identification unit)	27
7.10	Resetting the circuit breaker	27
7.11	System information	27
7.12	Spare and wearing parts	28
	7.12.1 ACX1180C	28
	7.12.2 Refrigerant identification unit	28
8.	Disposal	28
8.1	Disposal of electronic parts	28
8.2	Disposal of LCD screen	28
8.3	Disposal of refrigerants, UV dye, lubricants and oils	28
8.4	Disposal of combo filter	28
9.	Technical data	29
9.1	ACX1180C	29
9.2	Electromagnetic compatibility	29
10.	Glossary	29
11.	Notes	30

1. Symbols use

1.1 In the documentation

1.1.1 Warning notices—Structure and meaning

Warning notices warn of dangers to the user or people in the vicinity. Warning notices also indicate the consequences of the hazard as well as preventive action. Warning notices have the following structure:

Warning symbol **KEY WORD – Nature and source of hazard!**
Consequences of hazard in the event of failure to observe action and information given.
 ➤ Hazard prevention action and information.

The key word indicates the likelihood of occurrence and the severity of the hazard in the event of non-observance:

Key word	Probability of occurrence	Severity of danger if instructions not observed
DANGER	Immediate danger impending	Death or severe injury
WARNING	Possible danger impending	Death or severe injury
CAUTION	Possible dangerous situation	Minor injury

1.1.2 Symbols in this documentation

Symbol	Designation	Explanation
⚠	Attention	Warns about possible property damage.
i	Information	Practical hints and other useful information.
1. 2.	Multi-step operation	Instruction consisting of several steps.
➤	One-step operation	Instruction consisting of one step.
⇨	Intermediate result	An instruction produces a visible intermediate result.
➔	Final result	There is a visible final result on completion of the instruction.

1.2 On the product

⚠ Observe all warning notices on products and ensure they remain legible.



➤ Wear protective goggles.



➤ Wear protective gloves.

2. Important notes



Before start up, connecting and operating MAHLE products it is absolutely essential that the Original instructions/owner's manual and, in particular, the safety instructions are studied carefully. By doing so you can eliminate any uncertainties in handling MAHLE products and thus associated safety risks upfront; something which is in the interests of your own safety and will ultimately help avoid damage to the device. When a MAHLE product is handed over to another person, not only the Original instructions but also the safety instructions and information on its designated use must be handed over to the person.

2.1 User group

The product may be used by skilled and instructed personnel only. Personnel scheduled to be trained, familiarized, instructed or to take part in a general training course may only work with the product under the supervision of an experienced person.

All work conducted on pressurized equipment may be performed by persons with sufficient knowledge and experience in the field of refrigeration, cooling systems and coolants and, also be aware of the risks involved in the use of pressurized devices.

2.2 Agreement

By using the product you agree to the following regulations:

Copyright

Software and data are the property of MAHLE or its suppliers and protected against copying by copyright laws, international agreements and other national legal regulations. Copying or selling of data and software or any part thereof is impermissible and punishable; in the event of any infringements MAHLE reserves the right to proceed with criminal prosecution and to claim for damages.

Liability

All data in this program is based—where possible—on manufacturer and importer details. MAHLE does not accept liability for the correctness and completeness of software and data; liability for damage caused by faulty software and data is ruled out. Whatever the event, MAHLE liability is restricted to the amount for which the customer actually pays for this product. This disclaimer of liability does not apply to damages caused by intent or gross negligence on the part of MAHLE.

Warranty

Any use of non-approved hardware and software will result in a modification to our product and thus to exclusion of any liability and warranty, even if the hardware or software has in the meantime been removed or deleted.

No changes may be made to our products. Our products may only be used in combination with original accessories and original service parts. Failing to do so, will render null and void all warranty claims.

This product may only be operated using MAHLE approved operating systems. If the product is operated using an operating system other than the approved one, then our warranty obligation pursuant to our supply conditions will be rendered null and void. Furthermore, we will not be held liable for damage and consequential damage incurred through the use of a non-approved operating system.

2.3 Obligation of contractor

The contractor is obliged to ensure that all measures geared towards the prevention of accidents, industrial diseases, labor-related health risks are taken and measures towards making the workplace fit for people to work in are carried out.

Basic rules

The contractor is bound to ensure that all electrical equipment and operating material is set up, modified and maintained by skilled electricians only or under the guidance and supervision of a skilled electrician in accordance with electrical engineering principles.

Furthermore, the contractor must ensure that all electrical equipment and operating material is operated in keeping with electrical engineering principles.

If a piece of electrical equipment or operating material is found to be defective, i.e. it does not or no longer complies with electrical engineering principles, the contractor must ensure that the fault is rectified immediately and, in the event that imminent danger exists, also ensure that the electrical equipment or the electrical operating material is not used.

Tests:

- The contractor must ensure that all electrical systems and equipment are tested by a qualified electrician or under the guidance of a qualified electrician to ensure they are in proper working order:
 - Before starting for the first time.
 - After modification or repair before starting for the first time.
 - At given intervals. Set intervals such as to ensure that faults that can be expected to occur are determined in good time.
- The test is to take the electrical engineering principles relating hereto into account.
- Upon request of the trade association, a test manual is to be maintained into which specific entries are made.

2.4 Safety regulations

2.4.1 ACX1180C

Always carefully study and follow all the safety regulations before using the MAHLE product.



Avoid all skin contact with the refrigerant. The low boiling point of the refrigerant (approx. -30°C) can lead to frostbite. Should refrigerant come into contact with the skin, remove any moistened clothing immediately and rinse the area of skin affected with generous amounts of water.

- Avoid all skin contact with the UV dye. Should UV dye come into contact with the skin, remove any moistened clothing immediately and rinse the area of skin affected with generous amounts of water.
- R134a is colorless, with weak characteristic smell and heavier than air. It may flow into repair pits. Should refrigerant escape, provide for sufficient ventilation (particularly in repair pits) and leave the workshop.



Never inhale refrigerant, dye and oil vapors. The vapors can irritate the eyes, nose and respiratory system. If liquid refrigerant or UV dye comes into contact with the eyes, rinse them thoroughly with water for 15 minutes. Then obtain medical attention even if no pain is felt.

- Never swallow UV dye. Should it be swallowed inadvertently, never attempt to induce vomiting. Drink generous amounts of water and obtain medical attention.
- Before connecting the ACX1180C to a vehicle air conditioning system or an external refrigerant bottle, make sure the quick-release couplings are not leaking. Only ever use external refrigerant bottles provided with safety valves and certified inline with the applicable standards.
- Before switching off the ACX1180C, make sure all charging and drainage operations have been completed. This prevents damage to the unit and reduces risk of refrigerant escaping into the environment.



Never use compressed air with R134a. Certain mixtures of air and R134a are highly flammable. Such mixtures are a potential hazard and may lead to fire or explosions and thus cause damage or injury.

- Refrigerant extracted from a vehicle air conditioning system may be contaminated with moisture, lubricant, dirt and traces of other gases.
- The ACX1180C is provided with a refrigerant identification system designed to prevent contamination with other refrigerants.
- If the refrigerant has been contaminated by being mixed with other gases, remove the contaminated refrigerant and add fresh R134a before using the ACX1180C for A/C service.
- R134a is not to be used in areas in which there is a danger of explosion. Fire, open flames and smoking are prohibited. Welding and soldering are not permitted.
- The ACX1180C unit should not be exposed to excess moisture or be operated in wet areas.
- R134a is not to be mixed with other refrigerants. The mixing of refrigerants could damage the vehicle air conditioning system.



If high-voltage components or high-voltage wires are handled incorrectly, there is a risk of fatal injury from high voltage and the possible transmission of current through the body.

- De-energizing is only to be performed by a qualified electrician, a qualified electrician for specific tasks (hybrid) or a power systems engineer.
- Work on vehicles with high-voltage components is only ever to be performed in a safe, de-energized condition by persons with the minimum qualification "Trained to perform electrical work".
- Even after deactivating a high-voltage vehicle electrical system, the high-voltage battery may still be live.
- Operating condition cannot be established from any running noise, as the electric machine is silent when stationary.
- In gear positions "P" and "N" the engine or electric motor may start spontaneously depending on the charge of the high-voltage battery.
- Never open or damage high-voltage batteries.
- On vehicles that have been in an accident, never touch high-voltage components or exposed high-voltage wires before deactivating high-voltage vehicle electrical system.
- The ACX1180C must be constantly monitored when in operation. Never leave the ACX1180C unattended when in operation.
- Vehicle A/C service using the ACX1180C must be prepared and implemented such that the vehicle air conditioning system circuit does not have to be opened (for example by removing the radiator or engine).

- Position the ACX1180C on all four wheels on a flat, vibration-proof surface so that proper operation of the scales is guaranteed.
- The ACX1180C can be secured in position by locking the caster brake.
- The ACX1180C must always be transported in its operating position. Never lay the ACX1180C on its side, as oil could then escape from the vacuum pump or the built in compressor could be damaged.
- There are no additional safety systems for protecting the ACX1180C against damage resulting from natural catastrophes.
- Never remove any components from inside the ACX1180C except for maintenance or repair purposes.
- Follow the pertinent legal regulations or directives to ensure safe handling of pressurized devices.
- We recommend calibrating the scales at least once per year. Contact customer service for calibration of the scales.
- The ACX1180C must be subjected to regular maintenance by service personnel or authorized agents to ensure the safety of the unit.
- Disconnect power before performing any maintenance or service to unit.
- Never perform any maintenance work which is not expressly recommended in this manual. Contact customer service if components have to be replaced other than in the course of maintenance work.
- ACX1180C must be connected to a properly grounded electrical connection.
- If there is damage to the ACX1180C, terminate usage immediately and contact customer service.
- The service hoses and service quick-release couplings must be regularly checked for wear and replaced if damaged.
- The ACX1180C must be operated in an environment that will provide at least four air changes per hour.
- Observe local laws or directives as to ensure the safety of the pressurized device.

- For safety reasons it is advisable to use a residual current operated circuit breaker (rccb) with the following specifications:

Parameters	Specification
Rated voltage	120VAC ± 10%
Rated frequency	50/60 Hz
Rated current	10 A
Rated tripping current	30 mA
Tripping switch	C

- Avoid using an extension cord with the unit. If necessary, use a good condition (three wire grounded, #14AWG or larger) extension cord of the shortest possible length. In addition, the current drawn by all devices connected to the wall socket must not exceed 15A total.

2.4.2 Refrigerant identification unit

- Inspect the outside diameter of the white sample filter element before and after each use of this unit. As soon as red spots begin to appear on any portion of the white element outside diameter, the filter requires replacement. Failure to replace the filter when so indicated may result in damage to the identification unit (out of warranty).
- This unit requires connection of the sample fitting to the LP side port of the source vehicle or refrigerant cylinder. Connection of the test hose to the high, or liquid, port of the source vehicle or refrigerant bottle will result in damage to the unit (out of warranty).
- Inspect the test hose before and after each use of the unit. Immediately replace the hose if it appears cracked, obstructed, or fouled with oil.
- Never use a test hose other than those approved for use with the Identifier.
- Never connect the Identifier to any refrigerant source that exceeds 300 psi pressure.

2.5 Safety devices

Description	Function
Pressure switch	Switches the compressor off if the normal operating pressure is exceeded.
Safety valve	The safety valve opens if the design pressure is exceeded.
Circuit Breaker	Interrupts the power supply if overcurrent is applied to the ACX1180C.
Vents	The ACX1180C is provided with vents in the bottom of the housing to ensure the exchange of air even when switched off.

3. Product description

3.1 Application

ACX1180C is suitable for vehicles with a conventional engine as well as for hybrid and electric vehicles. ACX1180C features all the functions required for vehicle A/C service.

The following functions can be implemented:

- Refrigerant recovery and recharging.
- Vacuum generation.
- Enhanced vacuum.
- Flushing.
- Refrigerant identification (Optional accessory).
- Printing report.
- High pressure leak check.
- A/C system test mode.

⚠ The ACX1180C can only be operated with R134a. The ACX1180C is not to be used for service work on vehicles with air conditioning systems employing refrigerants other than R134a, as this will cause damage. Prior to A/C service check the type of refrigerant used in the vehicle air conditioning system.

3.2 Scope of delivery

Description
Handle
Service hose (high pressure)
Service hose (low pressure)
Quick-release coupling (high pressure)
Quick-release coupling (low pressure)
Used oil bottle
Operation manual
Adapter (external bottle), US Acme 1/2
Calibration check ball
Inline filter set (2x)
Refrigerant identifier (optional item)
Printer
Temperature probes (3x)
Hex key for handle installation

3.3 Description of unit

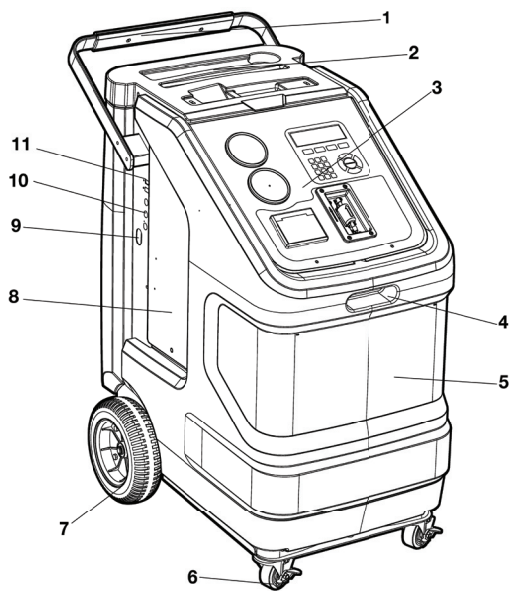

Fig. 1: Front view

- 1 Rear handle and grip
- 2 Tool tray and storage
- 3 Display and operating unit
- 4 Front handle
- 5 ACX1180C front housing
- 6 Locking caster
- 7 Rear wheel
- 8 Service door
- 9 Vacuum pump sight glass viewing window
- 10 Temperature probe ports
- 11 USB port

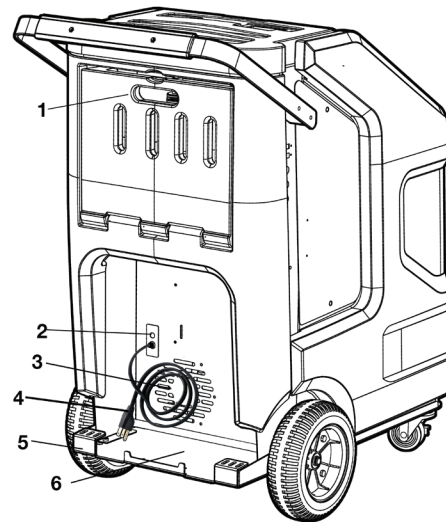

Fig. 2: Rear view

- 1 Service door for used oil and vacuum pump oil
- 2 Power supply cable inlet, circuit breaker
- 3 Fan
- 4 Power supply cable
- 5 Kick plate
- 6 Spare refrigerant bottle/Flush device storage shelf

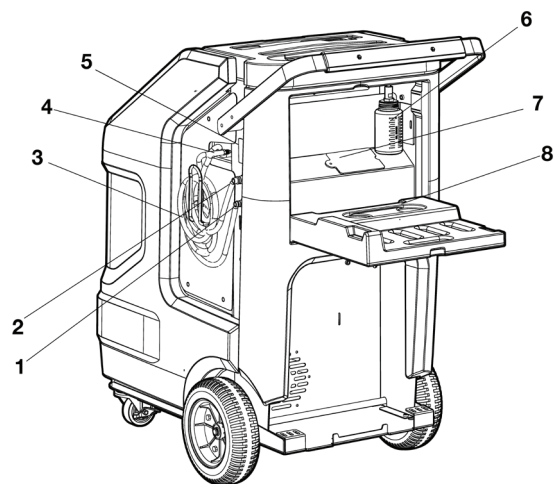

Fig. 3: Left-rear view

- 1 Low-side parking/flush adapter
- 2 High-side parking/flush adapter
- 3 Service hose
- 4 Service hose connections
- 5 Power switch
- 6 Used oil bottle
- 7 Vacuum pump oil fill access port
- 8 Service door for oil bottles and vacuum pump

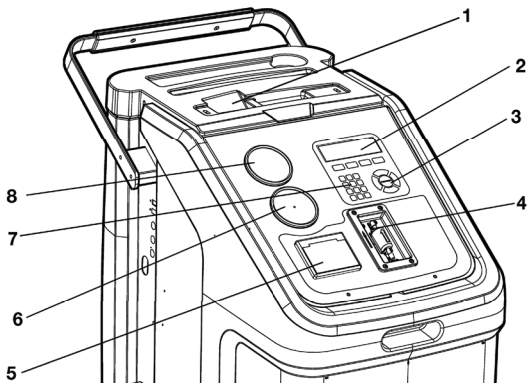

Fig. 4: Display and operating unit

- 1 TechALERT mounting area (Accessory)
- 2 LCD
- 3 Selection and function keys
- 4 Refrigerant identifier (Accessory)
- 5 Printer
- 6 Low-pressure gauge
- 7 Input keys
- 8 High-pressure gauge

The pressure gauges (Fig. 4, Pos. 6, 8) of the display and operating unit are used to monitor the pressure during the individual vehicle A/C service phases. The status of the various service phases during maintenance is displayed on the multicolor LCD screen (Fig. 4, Pos. 2). The necessary entries are made by way of the input keys (Fig. 4, Pos. 7) on the keypad.

The selection and function keys (Fig. 4, Pos. 3) on the keypad are used to control the operator interface menu options.

If a situation arises where unit software requires updated, MAHLE has a USB stick available for updating the ACX1180C software. The USB stick can be inserted in the USB socket to perform updating of the firmware/software.

- i** Refer to Section 7.7 for detailed information on the software updating procedure.

3.3.1 Selection and function keys

Keys	Name	Function
	Yes	Confirm and store
	No	Stop procedure, Exit menu
	▲ or ▼	Up or down control
	◀ or ▶	Right or left control
	Automatic	Takes operator directly to Automatic process
	Recycle	Takes operator directly to Recycle process
	Vacuum	Takes operator directly to Vacuum process
	Charge	Takes operator directly to Charge process
	Unit of Measure	Toggle units displayed on LCD display

Various functions are assigned to the function keys in the ACX1180C software. The functions of the keys are defined in the menu line of the ACX1180C software.

3.3.2 Input keys

The input keys can be used to enter letters, numbers and special characters in the input boxes. If a key is pressed several times in succession in the input box, all the characters which can be used for this are displayed.

- i** Pressing the #4 key when at the main menu provides quick access to the Language selection screen. Follow on-screen instructions to change language.
- i** Pressing the #7 key when at the main menu does an automatic Oil Drain process.

3.3.3 Printer

- ❗ Service reports can be printed out.
- ⚠️ Protect thermal printer paper against direct sunlight, heat, oils, greases, tanning agents and materials containing plasticizers (e.g. PVC folders).
- ❗ If print to flash drive is enabled (See Selectable Options section) and a flash drive is inserted in USB port, a duplicate report will be generated. Files are saved to USB as a text file by date.

3.3.4 Service doors

- ❗ There are two service doors: One on the left side and one on the rear of the housing.
- ❗ Tools can be placed on the upper cover.
- ❗ The service door on the side provides access to the the internal refrigerant bottle, and the filter drier.
- ❗ The service door on the rear permits access to the Vacuum pump oil fill/drain and used oil.

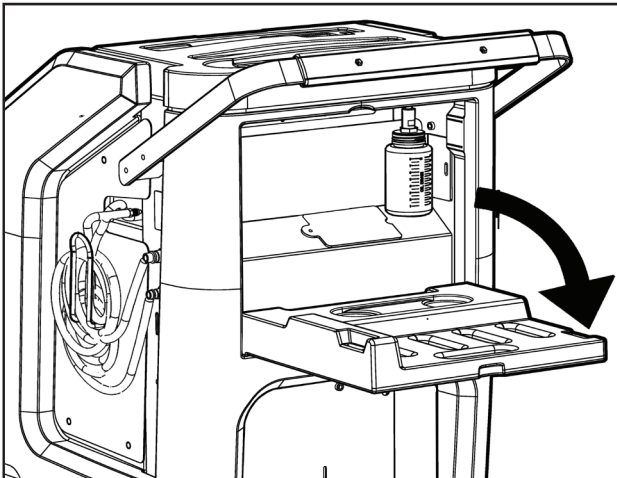

Fig. 5: Opening service door on back

To open the service door on the cover, remove the two Phillips head screws and take out the service door.

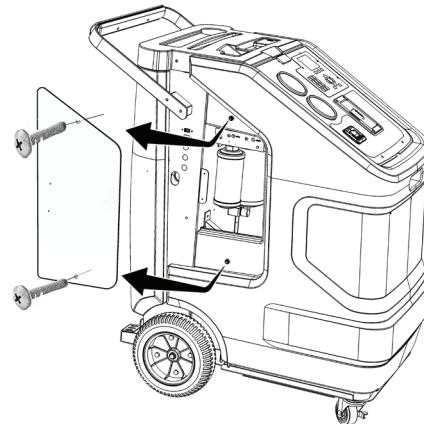

Fig. 6: Removing service door

- ⚠️ Never attempt to operate the ACX1180C without service doors, as this would make the working area dangerous. The housing of the ACX1180C was designed with a built-in ventilation fan to prevent the accumulation of potentially flammable R134a refrigerant vapors.

3.3.5 Oil bottles

The used oil bottle should be checked prior to every service to ensure there is sufficient room for any oil that is recovered during the A/C service.

Used oil bottle

- ❶ To remove the used oil bottle, twist connection counter-clockwise and remove bottle.

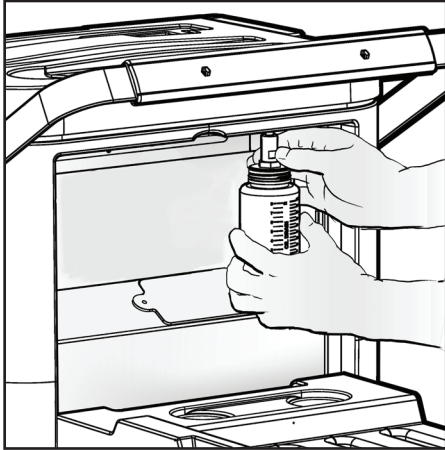

Fig. 7: Removing used oil bottle

Symbol	Description
	Used oil bottle

3.3.6 Service quick-release couplings

- ❶ The service quick-release couplings are connected to the service connections of the vehicle air conditioning system during A/C service. When not in use, the service quick-release couplings can be connected to the parking/flush couplers.
- ❶ To remove the service quick-release couplings from the parking/flush coupler, (Fig. 8), press the coupling slightly towards the connection and carefully pull the knurled section back to unfasten it from the coupler.

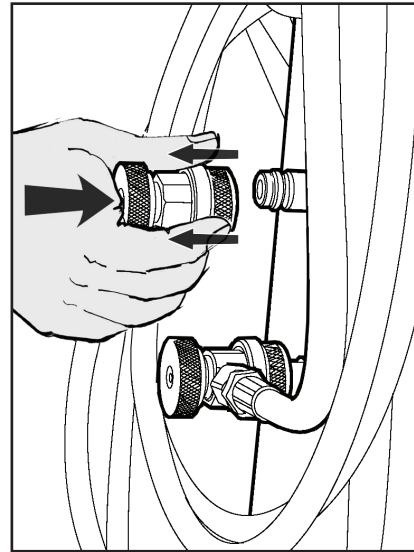

Fig. 8: Unfastening quick-release coupling

- ❶ To connect the coupling, position the coupling on the parking coupler/Flush adapter, pull back the knurled section of the coupling element and press carefully onto the connection.

EcoLOCK® quick couplers

EcoLOCK® is the intelligent coupler, that if included and with the suitable automated procedure in the software enables to:

- reduce the amount of non-condensable gases formed inside the cylinder,
- avoid the refrigerant dispersion (loss) in the air during the disconnection of the couplers (puff-effect),
- check possible valve core leaks before disconnection.



Fig. 9: EcoLOCK® couplers

3.3.7 Inline filters

The service hoses are connected to the ACX1180C by way of the inline filters. The inline filters prevent the ingress of fine particles into the internal hydraulic circuit of the ACX1180C.

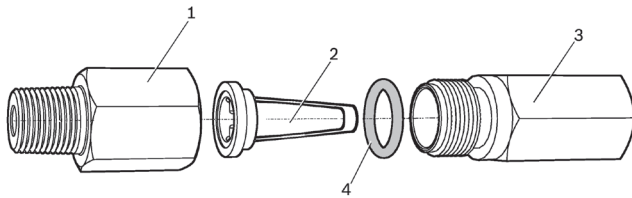

- 1 Adapter for connection
- 2 Filter element
- 3 Adapter for hoses
- 4 Sealing ring

3.3.8 Locking caster brakes

Rolling of the ACX1180C can be prevented by locking the caster brakes (Fig. 1, Pos. 6) at the rear wheels.

3.3.9 Power supply cable and switch

The power supply cable is connected to the back of the unit. When not in operation, the power supply cable can be coiled up and set on the spare tank storage area on the back of the ACX1180C.

The ACX1180C is switched on by toggling the rocker switch to the On position.

3.4 Refrigerant identification unit (Optional)

The refrigerant identification unit permits precise determination of the type of refrigerant as to prevent cross contamination by other refrigerants.

⚠ Only after successful identification of refrigerant, service hoses may be connected to the vehicle.

ℹ The refrigerant identification unit is incorporated into the service procedure and thus always to be used for A/C service.

3.4.1 Delivery

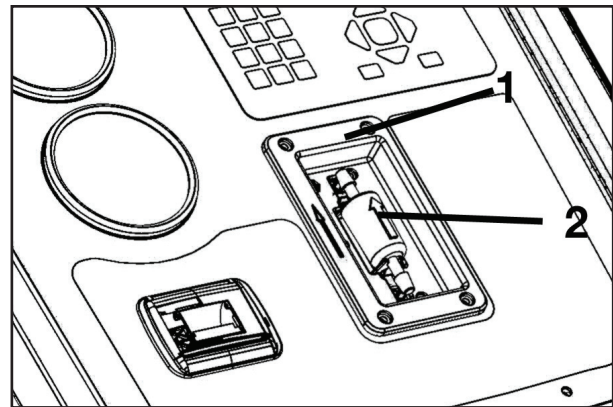

Fig. 10: Refrigerant identification unit—delivery

- 1 Refrigerant identification unit
- 2 White sample filter

3.5 Functional description

The ACX1180C was designed with menu driven prompts on the display to guide technician through the service setup.

The display shows data such as the internal cylinder weight and prompts technician for input using the alphanumeric keypad and various navigation buttons.

The ACX1180C can be used to perform a fully automatic A/C service. The technician will be prompted for entry of data such as charge amount and given options such as performing leak tests. Once necessary data has been entered, the ACX1180C will automatically complete an A/C service and alert the technician for interaction (if necessary) or when complete.

The ACX1180C can be used to perform the individual functions of an A/C service as well (Recycle, Vacuum or Charge).

A setup routine can be used to select specific options, set default values, perform maintenance operations and manage fluid capacities processed.

The refrigerant recovered from the air conditioning system passes through the combo filter to remove suspended particles and moisture.

The purpose of the vacuum pump is to generate a vacuum in the air conditioning system which removes excess moisture and to detect possible leaks in the vehicle air conditioning system.

Used oil separated from the vehicle refrigerant recovered drains into the used oil bottle.

Oil removed from the vehicle A/C system compressor during the recovery process should be manually injected into the A/C system prior to recharging the system.

The vehicle air conditioning system is partly filled with UV dye to facilitate the detection of leaks in the event of damage to the vehicle air conditioning system.

The refrigerant in the internal refrigerant bottle is used for filling the vehicle air conditioning system.

The purging unit for the non-condensable gases, consisting of a temperature sensor, pressure sensor, coil and orifice, always takes effect when the internal refrigerant bottle pressure is higher than the saturation pressure.

Refrigerant identification is a menu-driven process implemented by a refrigerant identification unit which is integrated into the ACX1180C (when option is turned on).

4. Commissioning

- ❗ All the operations described in Section 4 must be performed prior to first A/C service.

4.1 Removing transportation packaging

- ⚠ When removing the packaging, use care to ensure there is no damage caused to the ACX1180C unit or any of the included accessories.

- ❗ Do not unplug any electrical connections and only have internal components opened and repaired by trained customer service personnel.

- ❗ Contact customer service in the event of any transportation damage (e.g. oil leakage).

4.2 Attaching handle

1. Remove plastic bubble wrap from handle.
2. Locate hex (Allen) key included in document packet of unit.
3. Using included hex (Allen) key, remove bolt from rear handle mounting hole (both sides of ACX1180C unit).
4. Rotate handle upwards and over top of the handle mounting spacers.

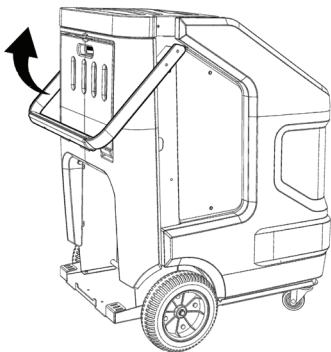

Fig. 11: Setting up handle

5. Insert the bolt on each side through handle and the spacer and tighten.

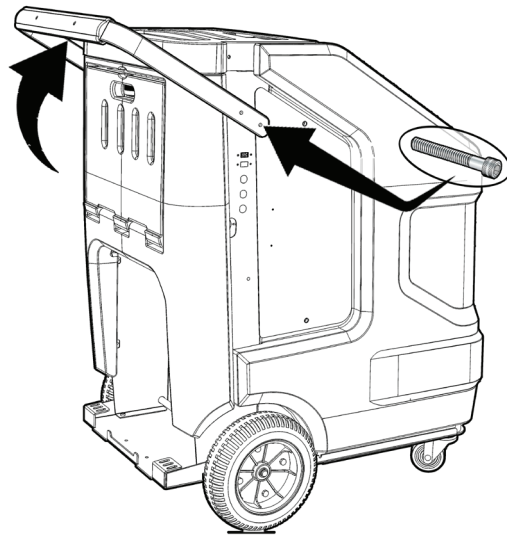

Fig. 12: Insert bolt and tighten

6. Tighten the bolt at the front side of the handle to ensure it does not come loose at a later time.

4.3 Attaching Temperature Probes

- ❗ Connect the 3 temperature probes to the left side of ACX1180C unit. The connection is located on the left side of unit below the USB port. Place probe #1 at the top, #2 in the center and #3 at the bottom socket.

4.4 ACX1180C

⚠ The ACX1180C is designed for 120VAC ± 10%, 50/60 Hz. Follow the information on ACX1180C rating plate.

1. Set the ACX1180C on a flat, vibration-proof surface.
2. Actuate the caster brake to stop ACX1180C from rolling.
3. Connect the power supply cable to the power supply.
4. Switch on the main switch.
 - ⇒ The unit will prompt user to Select Language.

```
WE I G H T =   # # . #   L B
AUTOMAT I C
                                     S T A R T ?
```

4.4.1 Setting language

1. During first time setup, the unit will automatically prompt user to select a language. After this, it will be necessary to use ▼ or ▲ to get to **Setup** and press **YES**.
1. Press **YES** again to enter **Selectable Options** (or press and hold #4 key from Main Menu).
2. Select language with ▼ or ▲.
3. Store selection with **YES**.

4.4.2 Setting date and time

1. From main screen, use ▼ or ▲ to get to **Setup** and press **YES**.
2. Use ▼ or ▲ to scroll to **Maintenance Options** and press **YES** again.
3. Press **NO** until **Set Date and Time** is displayed.
4. Alter values with ▼ or ▲.
5. Move to next value with ◀▶.
6. Store entries and return with **YES**.

4.4.3 Activating / deactivating printer, buzzer

1. From main screen, use ▼ or ▲ to get to **Setup** and press **YES**.
2. Press **YES** again to enter **Selectable Options**.
3. Press **YES** button to scroll though various options.
4. Activate/deactivate by using ▼ or ▲ to select **YES** or **NO**.
5. Store entries by changing selection and pressing the **YES** button. Escape by pressing **NO** button.

4.5 Setup

ⓘ The default service manager password is 5237.

4.5.1 Selectable Options

1. From main screen, use ▼ or ▲ to get to **Setup** and press **YES**.
2. Press **YES** again to enter **Selectable Options**.
3. Press **YES** button to scroll though various options.
4. Activate/deactivate by using ▼ or ▲ to select **YES** or **NO**.

Option	Description
Select language	Select language to be displayed on screen.
Buzzer enabled?	Audible alarm additionally sounds in the event of error messages.
Refrig ID installed?	Optional accessory that can be purchased and added at user convenience.
AC Cap DB installed?	Optional accessory that can be enabled.
Printer installed?	Print results for records.
Print to flash drive?	Print results to flash drive for records.
Low voltage detect enabled?	Enables/disables low voltage shutdown.
Micron vacuum sensor enabled?	Enables/disables use of micron sensor to check vacuum level.
Password protection enabled?	Optional setting if password protection preferred.
VIN entry enabled?	Allows technician to enter vehicles VIN number that is being serviced.
Operator ID entry	Allows technician to enter user data for log.
AC test mode enabled?	Allows use of ACX unit to test the A/C system.
Vacuum pump oil life test enabled?	Use vacuum pump micron sensor to check effective life of oil.
Refrigerant liquid flush enabled?	Flush components with liquid refrigerant.
Techalert demomode enabled?	If TechALERT is purchased, the demo can be enabled to demonstrate use.
High pressure leak detect enabled?	Build tank pressure and charge A/C system with higher pressure to assist in finding small leaks.
Automatic weighing oil injection enabled?	Feature not currently applicable.
Automatic weighing oil drain enabled?	Feature not currently applicable.
High voltage oil flush enabled?	Allows technician to flush hoses when changing between PAG and POE oil systems.
Fill cylinder enabled?	Allows user to fill internal cylinder from external refrigerant tank.
Manual oil injection enabled?	Allows user to manually inject oil between vacuum and charge procedure.
Ecolock couplings enabled?	If enabled and unit is equipped with EcoLOCK couplers, unit will remove refrigerant trapped between coupler and port on A/C system.

4.5.2 Default Values

1. From main screen, use ▼ or ▲ to get to **Setup** and press **YES**.
2. Scroll to **Default Values**, press **YES** to enter.
3. Press **YES** button to scroll through various options.
4. Modify values by using ◀▶ to select position of cursor and the numeric keypad to change entered value. Press **YES** to accept value.

Option	Description
Fill Cylinder target amount	The value set here will be the amount of refrigerant which will have been transferred when the procedure stops automatically.
Initial vacuum hold	This sets value where vacuum pump will pull the A/C system into a vacuum and then pause for a period of 60 seconds.
Final vacuum level	This sets the target vacuum level for service.
Vacuum run time	This screen prompts for the length of time the vacuum pump will run during each cycle.
Hose overcharge amount	A small overcharge of refrigerant is necessary to compensate for refrigerant which will remain in the hose after a charge procedure
Default minimum line voltage	During machine operation, the line voltage is monitored to remain above a threshold to ensure correct operation.
Elevation from sea level	Elevation from sea level to adjust pressure transducer calibration.
Oil life vacuum rise level	Enter the amount of rise in vacuum level used during the vacuum pump oil life test
Oil drain max level	Currently not applicable.
Minimum vacuum leak level	During vacuum leak test, this value is used to determine a pass or fail.
High voltage flush charge amount	Used to set amount of refrigerant used in flush routine. DO NOT REDUCE THIS VALUE TO LESS THAN 1.6LBS ; risk of residual oil may be left in hoses!
Default vacuum leak time	Used to set amount of time vacuum leak process will check for potential leaks.

4.5.3 Maintenance Options

1. From main screen, use ▼ or ▲ to get to **Setup** and press **YES**.
2. Use ▼ or ▲ to scroll to **Maintenance Options** and press **YES** again.
3. Press **YES** or **NO** to either select or bypass the different options.
4. Alter values with ▼ or ▲.
5. Move to next value with ◀▶.
6. Store entries and return with **YES**.

Option	Description
Perform calibration check?	Press YES if desired. When prompted, attach supplied steel calibration check ball to magnet at bottom of load cell to continue check.
Perform internal load cell site calibration	Press YES if required, press NO otherwise. If required, special 4KG weight required and available for purchase (see Accessory Items).
Perform internal load cell shop calibration.	Press YES if required, press NO otherwise. If required, special 10KG weight required and available for purchase (see Accessory Items).
Set date and time?	Press YES key if adjustment needed, press NO otherwise. If adjustment is needed, use ▲▼ to modify value and press YES to accept entry.
Perform Input/Output diagnostics?	Use this to test solenoid and sensor function. Also can monitor sensor values for troubleshooting purposes.
Perform combo filter replacement	Press YES key if replacement needed. Press NO otherwise. If YES selected, unit will check pressure in accumulator to ensure no refrigerant is present.
Perform vacuum pump oil replacement	Press YES key if replacement needed, press NO otherwise. Vacuum pump oil should be replaced every 10 hours for best performance.
Change operator password	If YES is selected, unit will ask for service manager password prior to allowing operator password change. Press NO to bypass password change.
Change service manager password	Press YES if desired, press NO otherwise.
Print parameter settings	Press YES if desired, press NO otherwise. If printer not installed, file can still be printed/saved to flash drive.

4.5.4 Total Capacities

1. From main screen, use ▼ or ▲ to get to **Setup** and press **YES**.
2. Use ▼ or ▲ to scroll to **Total Capacities** and press **YES** again.
3. Press **YES** to scroll through different values.

Option	Description
Combo Filter Life Remaining	Amount of refrigerant able to be processed until replacement of combo filter required.
Total Refrigerant Recycled	Total refrigerant recovered throughout life of unit.
Total Refrigerant Charged	Total refrigerant charged throughout life of unit.
Vacuum Pump Oil Life Remaining	Time remaining until vacuum pump oil must be replaced.

4.6 Checking type of connection of external refrigerant bottle

i Follow the instructions below for filling the internal refrigerant bottle.

- **Refrigerant bottle with one valve:**
Always turn the external refrigerant bottle upside down when filling the internal refrigerant bottle.
- **Refrigerant bottle with two valves:**
Use the adapter set to connect the service hose (LP) to the external refrigerant bottle. In doing so, turn the external refrigerant bottle such that the connections are facing upwards.

⚠ The internal refrigerant bottle should only be replaced if it is severely damaged. The internal refrigerant bottle must always be filled using an external refrigerant bottle.

⚠ During filling, the external refrigerant bottle must be firmly positioned and the operator must ensure that the service hoses are safely routed to avoid the danger of the external refrigerant bottle falling over.

4.7 Filling internal refrigerant bottle



Warning – Risk of frostbite from escaping refrigerant

Refrigerant causes severe frostbite on the skin.



- Check the service hoses for damage.
- Firmly connect the service quick-release couplings to the service hoses.



- Wear protective goggles.
- Wear protective gloves.

i Before the ACX1180C can be used, the internal refrigerant bottle must be filled with liquid refrigerant. Use only R134a refrigerant.

i The refrigerant can be obtained from your gas supplier. It can be stored normally and transported in bottles with connection fittings.

i To ensure a reliable procedure, it is advisable to use the optimum quantity of refrigerant. The optimum quantity of refrigerant for the ACX1180C is 10lbs (4.5kg) – 34lbs (15.5kg).

i An inadequate quantity may make efficient filling of the vehicle air conditioning system impossible. Also, if there is an insufficient quantity, the ACX1180C may not be able to operate efficiently. In the event of an excessive quantity, there may not be sufficient space for the refrigerant recovered from the vehicle air conditioning system.

⚠ Generally speaking, the actual quantity of refrigerant added exceeds the set quantity to allow a dead weight in the tank to keep the internal refrigerant circuit wetted. Add 1lb (454g) to the set quantity when filling with refrigerant for the first time.

1. To fill internal bottle, push ▼ until "Fill Cylinder" is displayed then press **YES**.
2. Follow the menu prompting.

i The current pressure inside the external refrigerant bottle is indicated on the low-pressure gauge.

i Any amount of refrigerant up to 38lb (17.5kg) can be added.

⚠ Do not interrupt the automatic filling process prior to automatic termination by the ACX1180C.

5. A/C service preparation



Warning – Risk of burns from hot engine components

Contact with hot engine components will cause severe burns.



- Allow the engine to cool down.
- Wear protective goggles.
- Wear protective gloves.



Warning – Risk of frostbite from escaping refrigerant

Refrigerant causes severe frostbite on the skin.



- Check the service hoses for damage.
- Firmly connect the service quick-release couplings to the service hoses.
- Wear protective goggles.
- Wear protective gloves.

Perform the following preparatory work prior to vehicle A/C service:

⚠ Service hoses must be constructed of the proper materials and have the lengths as supplied with the unit. Hoses must have shutoff devices (quick-release couplers) at the connection point to the A/C to minimize the introduction of air into the ACX1180C and to minimize the amount of refrigerant released while disconnecting the hoses.

⚠ Inspect hoses for signs of damage prior to performing A/C service. Use of damaged hoses will result in the loss of refrigerant and the possibility of refrigerant contamination.

ⓘ Follow the vehicle manufacturer's recommendations for A/C service on vehicles with a low-pressure connection only.

1. Set the ACX1180C on a flat, vibration-proof surface.
2. Actuate the caster brake to stop the unit from rolling.
3. Connect the power supply cable to the power supply.
4. Switch on the main switch.

ⓘ Follow the manufacturer's instructions for the corresponding vehicle before performing A/C service.

⚠ The ACX1180C is only to be operated with R134a refrigerant. Check which refrigerant is used for the vehicle before performing A/C service.

⚠ The ACX1180C cannot be used for air conditioning systems repaired using a chemical sealant. These sealants may cause serious damage to the ACX1180C if they are present. Detection devices are available to check for chemical sealants. Non compliance will void the warranty.

⚠ Never attempt to close the valves of the internal refrigerant bottle while the ACX1180C is in operation.

⚠ Only new lubricant, as specified by the system manufacturer, shall be installed in the MAC system. Lubricant removed from the system and/or equipment shall be disposed of in accordance with the applicable federal, state, and local procedures and regulations.

6. Operation

⚠ Before connecting service hoses proceed as follows:

1. Perform refrigerant identification (if equipped - see chapter 6.3).

6.1 Service phases

- **Recovery phase:** Refrigerant is extracted from the vehicle, cleaned and routed into the internal refrigerant bottle.
- **Vacuum phase:** A vacuum is generated in the vehicle air conditioning system and the system is checked for leaks.
- **Recharge phase:**
 - Refrigerant: The vehicle air conditioning system is filled with a specified amount of R134a refrigerant.

6.2 A/C Database

- ⓘ If purchased, the A/C Database can be used to select vehicle and determine the charge amount.
 1. To enable, go to "**Setup>>Selectable Options**".
 2. Press **YES** until screen displays "**AC CAP DB Installed?**".
 3. Use ▼ and ▲ to scroll to **External** and press **YES**.
 4. Once enabled, the unit will ask technician if they would like to use AC Capacity Guide to determine charge amount.
 5. If **YES** is selected, the unit will proceed to allow user to select Year, Make, Model, Engine, and any other options the vehicle may have.
- ⓘ Database is updated yearly with current model year vehicles. Updates can be purchased and downloaded through the MAHLE Aftermarket Inc. website.

6.3 Refrigerant identification unit

6.3.1 Refrigerant analysis

- ⚠ Oil contamination will damage the refrigerant identification unit! If the refrigerant sample is supplied to the unit from the recycling equipment directly, it must be protected from oil that comes from vehicles or accumulate in service hoses!
- ⚠ The operator must periodically examine the test hose and white sample filter for oil contamination and stop immediately if any oil is observed!
- ⓘ If installed and enabled, Refrigerant Identification will automatically occur anytime a Recycle or Internal Bottle fill is performed.
- ⓘ The gas pressure should be between 1.7 –16 bar. Accurate gas analysis can be achieved with less than 1.7 bar but additional time must be provided. In this case start the flow of gas and then wait for 20 seconds before instructing the refrigerant identification unit to test the gas.
- ⓘ After sample is completed, ID results will be displayed on ACX1180C screen.
- ⓘ If results show air percentage over 5%, check filter, hose and coupler for any potential contamination or leaks prior to repeating identification.

6.4 Automatic A/C service

⚠ Before connecting service hoses proceed as follows:

1. Perform refrigerant identification (if equipped - see chapter 6.3).
- ⚠ Only after successful identification of refrigerant, service may begin on the vehicle. (If Ref. ID installed and enabled).
- ⚠ The contamination of the ACX1180C internal bottle can only be removed by a service provider at additional cost.
- ❗ The service parameters (recharge quantity) can be found in the owner's manual or the vehicle repair manual.
1. Turn unit on and once the first screen is loaded, press **YES** to perform an **Automatic Cycle**. (Or use quick button at top of keypad.)
 2. Select vehicle from A/C Capacity Guide (if installed and equipped).
 3. Follow the menu prompting.
 4. Unit will perform Recycle, Vacuum, and Recharge.
- ❗ All service phases can be implemented manually with the ACX1180C.
- ❗ R134a can only be added to an air conditioning system in which there is a vacuum. The vacuum phase must therefore be implemented before filling with R134a.

6.5 Manual A/C service

⚠ Before connecting service hoses proceed as follows:

1. Perform refrigerant identification (if equipped - see chapter 6.3).
- ⚠ Only after successful identification of refrigerant, service may begin on the vehicle. (If Ref. ID installed and enabled).
- ⚠ The contamination of the ACX1180C internal bottle can only be removed by a service provider at additional cost.
- ❗ The service parameters (recharge quantity) can be found in the owner's manual or the vehicle repair manual.
1. Use ▼ or ▲ to scroll to desired service and press **YES**. (or push one of the buttons at the top of the keypad.)
 2. Follow the menu prompting.
- ❗ All service phases can be implemented manually with the ACX1180C.
- ❗ R134a can only be added to an air conditioning system in which there is a vacuum. The vacuum phase must therefore be implemented before filling with R134a.

6.6 Automatic/manual vehicle A/C service overview

Phases	Automatic mode	Manual mode		
		Recovery	Vacuum	Recharge
Checking of air conditioner pressure	x	x	x	x
Extraction of refrigerant	x	x	-	-
Separation of oil from refrigerant	x	x	-	-
Drainage of oil into used oil bottle	x	x	-	-
Formation of vacuum	x	x	x	-
Maintenance of vacuum	x	x	x	-
Recharging refrigerant	x	-	-	x
Pressure build-up	x	-	-	x

Tab. 1: Automatic/manual mode overview
x = is implemented

6.6.1 Recovery

- The pressure in the vehicle air conditioning system is checked prior to the recovery phase. The vacuum phase commences automatically if the air conditioning system is depressurized (empty).

6.6.2 Vacuum

- A vacuum is generated and maintained for time specified.
- Be sure recovery has been performed before generating the vacuum.
- On ACX1180C model units, an enhanced vacuum process is available. In this mode, the vacuum pump runs for the amount of time entered in the set up menus. A vacuum leak test will then begin and monitors vacuum level for a set time, then a second deep vacuum process will run for the length of time displayed.

6.6.3 Charging with refrigerant

- Service phases:** Pressure check, recharging.
- If pressure is detected in the vehicle air conditioning system during charging, recovery must be performed in order to continue.

6.7 Flushing after changing type of oil

⚠ When servicing a vehicle, the type of oil in the vehicle's A/C system should be noted to prevent a cross-contamination inside the ACX1180C. If a PAG system is serviced and another vehicle with a POE system is to be serviced next, a flush routine must be performed to prevent a cross-contamination of the oils.

⚠ If the ACX1180C is not flushed, the internal hydraulic system and the vehicle air conditioning system could be damaged as a result of cross-contamination. MAHLE cannot accept liability for any such damage.

- Use ▼ and ▲ to scroll to **High Voltage Oil Flush** and press **YES**.
- Follow the menu prompting.

⚠ High Voltage Oil Flush available on ACX1180H and ACX1180C model units only. These units will come with the flush adapter on the right side of the unit and will not have on-board oil injection available. Standard ACX1180 does not have full capability to perform this procedure.

6.8 Setting service parameters

- The parameters can be pre-set at the start of the corresponding service phase in manual and automatic A/C service.

Service parameters	Automatic vehicle A/C service	Manual vehicle A/C service		
		Recovery	Vacuum	Recharge
Vacuum time	x	-	x	-
Vacuum hold time	x	-	x	-
R134a refrigerant	x	-	-	x

Tab. 2: Setting parameters

⚠ Used oil must be disposed of in accordance with local regulations!

6.9 Non-condensable gases

- Purging takes place automatically in the ACX1180C on the basis of a pressure and temperature algorithm. The purged non-condensable gases are routed to the built-in ventilation fan and removed from the ACX1180C.

6.10 A/C System Test Mode

- ❗ The ACX1180C has a mode built in that allows the technician to test high and low side pressure. When using this mode, the hoses are connected to the vehicle and the 3 temperature probes are inserted in the cabin air ducts with the A/C on high. One probe can remain out to measure ambient condition.
- ❗ Unit will display A/C performance data. T1, T2 and T3 are temperature probe readings, HighPres is the pressure reading from the high side of the system, Low Pres is the pressure reading from the low side of the system, RH is the relative humidity. Note: the highest pressure is tracked and updated. The lowest pressure is tracked and updated. The lowest temperatures are tracked and updated.
- ❗ Press * to refresh or reset the data shown.
- ⚠ Once test is complete, disconnect high side (red) coupler from vehicle (with engine running and A/C on high) and press START. This allows the vehicle to pull any liquid refrigerant back from the hoses.

6.11 High Pressure Leak Detect

- ❗ The ACX1180C has a high pressure leak detection mode built in. This allows the technician to pressurize A/C system to a higher pressure and use a leak detector to find leaks.
- ❗ It is recommended to have between 8.8LB (4kg) and 34LB (15.5kg) in the internal cylinder for optimal performance.
- ⚠ Do not start vehicle A/C system if high pressure leak detect procedure was used! Compressor damage could result. Recycle procedure must be performed after leak detection.
- ❗ The unit will circulate refrigerant to build pressure inside the internal cylinder to the pressure entered in the set up screen. The recommended setting for most applications is 90PSI.

6.12 Refrigerant Flush

- ❗ Refrigerant flush will force liquid refrigerant in a reverse flow through a component or components to remove contaminants and oil. Special flush components and adapters are required to properly connect to standard A/C components.
- ⚠ Since refrigerant flushing removes all oil from the component being serviced, ensure the proper amount of oil is manually replenished.

7. Maintenance

7.1 Maintenance interval

Description	Period
Calibration of scale	1 x per year
Vacuum pump oil replacement and system leak test	After 10 hours of service
Inline filter replacement	Refer to filter drier
Combo filter replacement and system leak test	After 68kg (150lbs) of refrigerant processed
White sample filter of refrigerant identification unit	As soon as red spots begin to appear on any portion of the white element

⚠ Never perform any maintenance work which is not expressly recommended in this Section.

⚠ Contact customer service if components have to be replaced other than in the course of maintenance work.

7.2 Calibration of refrigerant scale

ⓘ The internal refrigerant bottle is calibrated at the factory.

1. Use ▼ and ▲ to select "Setup>> Maintenance Options".
2. Select a **Site Calibration** to perform a calibration using the MAHLE 4kg weight.
3. Follow on screen instructions to recalibrate unit.
4. Remove the calibrating weight once complete.

7.3 Calibration check

1. Use ▼ and ▲ to select "Setup>> Maintenance Options>>Calibration check".
2. Follow on screen instructions to check calibration.

ⓘ Getting message "calibration check failed", calibration check should be performed again and if it still fails a second time, a calibration of the internal refrigerant bottle scale should be performed.

7.4 Replacing inline filters

ⓘ The inline filters must always be changed when replacing the filter drier.

The inline filters consist of a filter element fitted in the hose adapter.

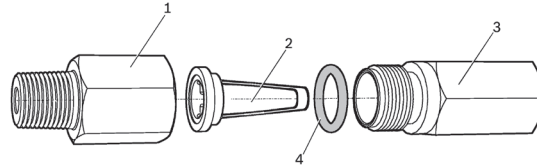

- 1 Adapter for connection
- 2 Filter element
- 3 Adapter for hoses
- 4 Sealing ring

1. Drain the service hoses.
2. Disconnect the service hoses from the inline filters.

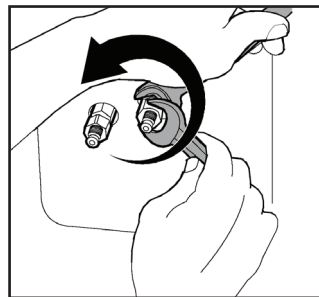

Fig. 13: Removing adapter

3. Remove the filter element.
4. Install the new filter element.

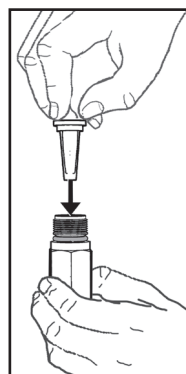

Fig. 14: Installing filter element

ⓘ Make sure the sealing ring is correctly positioned at the adapter and not damaged. Replace the sealing ring if it is damaged.

5. Screw the inline filter onto the adapter.
6. Attach the service hoses to the adapter.

7.5 Vacuum pump

7.5.1 Changing vacuum pump oil



Attention – Risk of burns from hot surfaces

Contact with the hot surface of the vacuum pump will cause severe burns.



- Allow the vacuum pump to cool down.
- Wear protective gloves.

i The vacuum pump oil must be changed after 10 hours of operation. The ACX1180C will display a reminder every 10 hours of vacuum pump use.

i Use the vacuum pump oil specified by MAHLE (part number 011 80070 00).

1. Place a container under the drain on back side of unit.
2. Open rear service door and slide open flap to expose oil fill port.
3. Open the drain plug and filler plug of the vacuum pump.
4. Drain all the oil.
5. Close the drain plug.
6. Pour vacuum pump oil into oil fill port until oil level is somewhere between the min and max lines.
7. Turn on unit and start a vacuum process.
8. Check oil level.

i Oil level is accurate when level is midway between full and empty.

➔ Oil change completed.

7.6 Combo filter

7.6.1 Changing Combo-Filter



Warning – Risk of frostbite from escaping refrigerant

Refrigerant causes severe frostbite on the skin.



- Check the service hoses for damage.
- Firmly connect the service quick-release couplings to the service hoses.



- Wear protective goggles.
- Wear protective gloves.

i Unit operation is disabled at the end of the filter service life. Each filter is marked with a unique code. This code must be entered when replacing the filter. It is not possible to operate the ACX1180C if the same code is re-used. It is advisable to keep a supply of filters in stock to avoid downtimes due to the unit being disabled.

i The ACX1180C is disabled once 68kg (150lbs) of R134a refrigerant have passed through the filter. A new filter must be installed and its unique code entered in the ACX1180C before vehicle A/C service can be performed.

i The message "Filter replacement due" appears once 57kg (125lbs) of refrigerant have passed through the filter. As soon as this warning message is displayed, contact customer service to order a new filter. The contact data can be found on the rating plate.

⚠ Pay attention to correct positioning of the two O-rings when fitting a new filter!

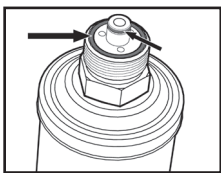

Fig. 15: O-Rings

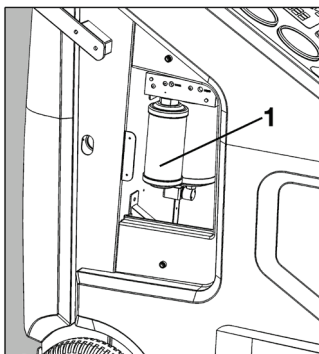

Fig. 16: Replacing filter

1. Combo filter

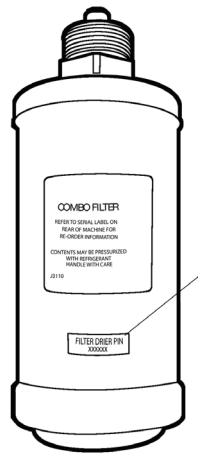

Fig. 17: Location of PIN number on filter

1 Code

1. Drain the service hoses.
2. Remove the right service door.
3. Loosen the filter, using a 1-3/8" (35 mm) wrench.
4. Remove the filter.

i Make sure the old sealing rings are removed before securing the new filter.

5. Insert a new filter.
6. Tighten the filter to 74 ft-lbs (100 N-m).
7. Secure the service door.

⚠ Take care not to damage any hoses or electrical connections when changing the filter.

⚠ Never re-use an old filter.

7.6.2 Resetting filter replacement interval

1. Use ▼ and ▲ to select "**Setup>>Maintenance Options>>Perform Combo Filter Replacement**".
2. Press **YES**.
3. Enter the 6-digit PIN number of the new filter.
4. Store entries and return with **YES**.

7.7 Software update

i The firmware (software) can be updated by way of a USB stick.

1. Insert USB update disk in USB port on side of unit.
2. Power on ACX1180C unit.
3. A message will appear that the unit is loading an update.
4. The unit may load an updated language file, database file and configuration file while updating.
5. Once unit is updated, the software version string on the introduction screen during power up will change.

7.8 Replacing printer paper

⚠ Avoid excessive force as not to damage the printer.

1. Push the button until the cover is released.
2. Change the roll of paper.
3. Close the cover.

i Paper is 58mm wide x 45mm diameter Thermal paper. Replacement paper can be found at most local office supply retailers or is available through MAHLE Service Solutions.

7.9 Replacing white sample filter (Refrigerant identification unit)

⚠ The need to replace the white sample filter may indicate oil contamination in the test hose. Replace the test hose if oil entrapment is found.

1. Switch off the ACX1180C unit.
2. Remove existing filter by pulling it straight out of the retaining clip.
3. Discard the used filter.

i Align the arrow on the filter with the arrow on the unit.

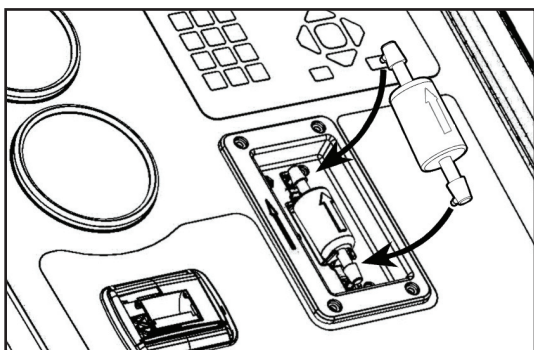

4. Position the filter into its retaining clip on the unit case.
5. Inspect clear refrigerant identification hose located on left side of unit. If hose is saturated with oil, it should be replaced along with the refrigerant identification hose inside the ACX1180C unit.

6. Remove the 4 screws that attach the plastic tool tray.
7. Remove the 2 screws that attach the front display unit.
8. Carefully open the front display. NOTE: This step may require operator to loosen the 2 locking-nuts at the pivot point to be able to open the display.
9. Once unit is open, inspect clear hose coming from back side of identifier down to center panel and through the rear panel.
10. Replace if necessary.
11. Fold display down and install 2 screws to front plastic.
12. Tighten locknuts at pivot point if they were loosened.
13. Reinstall tool tray and the 4 screws.

7.10 Resetting the circuit breaker

1. Switch off the ACX1180C and unplug from receptacle.
2. Allow unit to sit for a minute.
3. Look above fan on back of unit for the white button
4. Press white circuit breaker button back in to reset.
5. Plug in unit and turn back on.

7.11 System information

i The following items of system information can be displayed when under Output Diagnostics.

Display	Description
PT1	Pressure sensor/accumulator
PT2	Pressure sensor/internal refrigerant bottle
PT3	Pressure sensor/vacuum (service hoses)
PT4	Pressure sensor/high side
LC1	Quantity in internal refrigerant bottle
TS1	Temperature/internal refrigerant bottle
TS2	Temperature/Temp. Probe #1
TS3	Temperature/Temp. Probe #2
TS4	Temperature/Temp. Probe #3
HUM1	Relative Humidity (RH)
VAC1	Vacuum sensor

7.12 Spare and wearing parts

7.12.1 ACX1180C

Description	Order number
Replacement combo filter	360 82133 00
Vacuum pump oil	011 80070 00
Roll of paper for printer (5)	360 82218 00
Service hose (HP) - 15ft	028 80035 05
Service hose (LP) - 15ft	028 80036 05
Quick-release coupling (HP)	023 80095 00
Quick-release coupling (LP)	023 80096 00
Used oil bottle	360 82875 00
Oil charge bottle	360 82874 00
Operation manual	035 82337 00
Adapter (external bottle), US ACME 0.5"	023 80147 00
4 kg calibrating weight for internal ref. bottle	360 82734 00
Calibration check ball	360 82744 00
Inline filter set (10 x)	360 81618 00
Dust cover (accessory item)	360 83014 00
Leak detector (accessory item)	360 82955 00
Safety goggles (accessory item)	360 82956 00
Protective gloves (accessory item)	360 82957 00
Heat belt field install (accessory item)	360 82905 00
Sealant detection kit (accessory item)	360 81733 00

7.12.2 Refrigerant identification unit

Description	Order number
White sample filter	360 82958 00

8. Disposal

8.1 Disposal of electronic parts



This product is subject to the European directive 2002/96/EC (WEEE).

Old electrical and electronic devices, including cables, accessories and batteries, must be disposed of separately from household refuse.

- Please make use of the return and collection systems operating in your region.
- Proper disposal of old devices can help to avoid environmental pollution and health risks.

8.2 Disposal of LCD screen

Please dispose of the LCD screen in accordance with the local regulations governing the disposal of hazardous waste.

8.3 Disposal of refrigerants, UV dye, lubricants and oils

Refrigerants which can no longer be used must be returned to the gas supplier for disposal.

The lubricants and oils removed from air conditioning systems must be returned to official collection points. The UV dye must always be disposed of in accordance with the local regulations governing the disposal of hazardous waste.

8.4 Disposal of combo filter

Dispose of the filter via official collection points or in accordance with the local regulations.

9. Technical data

9.1 ACX1180C

Feature	Value/Range
Dimensions H x W x D	1016 x 580 x 840mm
Weight	110kg
Operating voltage	120VAC ± 10%
Frequency	50/60Hz
Workplace emission sound pressure level (as per EN ISO 11204)	< 70 dB(A)
Refrigerant	R134a
Pressure sensor	0 bar
Pressure sensor	0 bar – 34.5 bar
Pressure sensor	0 bar – 10.3 bar
Low-pressure gauge	-1 bar – 16 bar ± 1 % of final value
High-pressure gauge	-1 bar – 40 bar ±1% of final value
Capacity of internal refrigerant bottle	17.5kg
Maximum system pressure PS	20 bar
Pspec	18 bar
Power	900 W
Operating temperature	10°C – 50°C
Optimum R134a filling weight for operation	4kg – 15.5kg

9.2 Electromagnetic compatibility

This product complies with the standards EN 61000-6-2 and EN 61000-6-4.

10. Glossary

- **Recovery phase:** The refrigerant is extracted from the vehicle air conditioning system, cleaned and routed into the internal bottle of the ACX1180C. The refrigerant oil collected in the process is drained into the used oil bottle at the ACX1180C.
- **Vacuum phase:** A vacuum is generated in the vehicle air conditioning system. Measurement of the drop in pressure begins as soon as the vacuum has been generated.
- **Charging phase:** A certain quantity of refrigerant is added to the vehicle air conditioning system.

11. Notes



MAHLE Aftermarket Inc., Service Solutions

10 Innovation Drive
York, PA 17402
USA

717-840-0678

www.servicesolutions.mahle.com

035 82337 00 (REV A)
2016-05-26