

MAHLE ACX1280

EN Original instructions
AC Service Units



Contents

1. Symbols use	4	4. Commissioning	15
1.1 In the documentation	4	4.1 Removing transportation packaging	15
1.1.1 Warning notices—Structure and meaning	4	4.2 Attaching handles	15
1.1.2 Symbols in this documentation	4	4.3 ACX1280	16
1.2 On the product	4	4.3.1 Setting language	16
		4.3.2 Setting date and time	16
2. Important notes	4	4.3.3 Setting workshop data	16
2.1 User group	4	4.3.4 Activating / deactivating printer, workshop info, buzzer, operator list	16
2.2 Agreement	4	4.3.5 Maximum service data records	16
2.3 Obligation of contractor	5	4.4 Checking type of connection of external refrigerant bottle	17
2.4 Safety regulations	6	4.5 Filling internal refrigerant bottle	17
2.4.1 ACX1280	6		
2.4.2 Refrigerant identification unit	7	5. A/C service preparation	18
2.5 Safety devices	8		
		6. Operation	19
3. Product description	8	6.1 Service phases	19
3.1 Application	8	6.2 My database	19
3.2 Scope of delivery	8	6.3 Refrigerant identification unit	19
3.3 Description of unit	9	6.3.1 Refrigerant analysis	19
3.3.1 Selection and function keys	10	6.3.2 Decontamination	20
3.3.2 Input keys	10	6.3.3 Refrigerant verification	20
3.3.3 Printer	11	6.4 Automatic A/C service	21
3.3.4 Service doors	11	6.5 Manual A/C service	21
3.3.5 Scales for used oil and refrigerant	12	6.6 Automatic/manual vehicle A/C service overview	22
3.3.6 Service quick-release couplings	12	6.6.1 Recovery	22
3.3.7 Inline filters	13	6.6.2 Vacuum	22
3.3.8 Locking caster brakes	13	6.6.3 Charging with refrigerant	22
3.3.9 Power supply cable and switch	13	6.7 Flushing after changing type of oil	22
3.4 Refrigerant identification unit	13	6.8 Draining service hoses	22
3.4.1 Delivery	13	6.9 Setting service parameters	22
3.5 Functional description	14	6.10 Non-condensable gases	23
		6.11 System leak test	23

7.	Troubleshooting	24
7.1	ACX1280	24
7.2	Refrigerant identification unit	26
8.	Maintenance	27
8.1	Maintenance interval	27
8.2	Maintenance protocol	27
8.3	Calibration of scales	27
	8.3.1 Calibrating internal refrigerant bottle	27
	8.3.2 Calibrating used oil bottle scale	27
8.4	Calibration check	27
8.5	Taring of Scales	27
8.6	Replacing inline filters	28
8.7	Vacuum pump	28
	8.7.1 Changing vacuum pump oil	28
	8.7.2 Resetting oil change interval	28
8.8	Combo filter	29
	8.8.1 Changing Combo-Filter	29
	8.8.2 Resetting filter replacement interval	29
8.9	Software update	30
8.10	Replacing printer paper	30
8.11	Replacing white sample filter (Refrigerant identification unit)	30
8.12	Resetting the circuit breaker.	30
8.13	System information	30
8.14	Service Report	30
8.15	Spare and wearing parts	31
	8.15.1 ACX1280	31
	8.15.2 Refrigerant identification unit	31
9.	Disposal	31
9.1	Disposal of electronic parts	31
9.2	Disposal of LCD screen	31
9.3	Disposal of refrigerants, UV dye, lubricants and oils	31
9.4	Disposal of combo filter	31
10.	Technical data	32
10.1	ACX1280	32
10.2	Refrigerant identification unit	32
10.3	Electromagnetic compatibility	32
11.	Glossary	32
12.	Notes	33

1. Symbols use

1.1 In the documentation

1.1.1 Warning notices—Structure and meaning

Warning notices warn of dangers to the user or people in the vicinity. Warning notices also indicate the consequences of the hazard as well as preventive action. Warning notices have the following structure:

Warning symbol **KEY WORD – Nature and source of hazard!**
Consequences of hazard in the event of failure to observe action and information given.
 ➤ Hazard prevention action and information.

The key word indicates the likelihood of occurrence and the severity of the hazard in the event of non-observance:

Key word	Probability of occurrence	Severity of danger if instructions not observed
DANGER	Immediate danger impending	Death or severe injury
WARNING	Possible danger impending	Death or severe injury
CAUTION	Possible dangerous situation	Minor injury

1.1.2 Symbols in this documentation

Symbol	Designation	Explanation
⚠	Attention	Warns about possible property damage.
i	Information	Practical hints and other useful information.
1. 2.	Multi-step operation	Instruction consisting of several steps.
➤	One-step operation	Instruction consisting of one step.
⇒	Intermediate result	An instruction produces a visible intermediate result.
➔	Final result	There is a visible final result on completion of the instruction.

1.2 On the product

⚠ Observe all warning notices on products and ensure they remain legible.



➤ Wear protective goggles.



➤ Wear protective gloves.

2. Important notes



Before start up, connecting and operating MAHLE products it is absolutely essential that the Original instructions/owner’s manual and, in particular, the safety instructions are studied carefully. By doing so you can eliminate any uncertainties in handling MAHLE products and thus associated safety risks upfront; something which is in the interests of your own safety and will ultimately help avoid damage to the device. When a MAHLE product is handed over to another person, not only the Original instructions but also the safety instructions and information on its designated use must be handed over to the person.

2.1 User group

The product may be used by skilled and instructed personnel only. Personnel scheduled to be trained, familiarized, instructed or to take part in a general training course may only work with the product under the supervision of an experienced person. All work conducted on pressurized equipment may be performed by persons with sufficient knowledge and experience in the field of refrigeration, cooling systems and coolants and, also be aware of the risks involved in the use of pressurized devices.

2.2 Agreement

By using the product you agree to the following regulations:

Copyright

Software and data are the property of MAHLE or its suppliers and protected against copying by copyright laws, international agreements and other national legal regulations. Copying or selling of data and software or any part thereof is impermissible and punishable; in the event of any infringements MAHLE reserves the right to proceed with criminal prosecution and to claim for damages.

Liability

All data in this program is based—where possible—on manufacturer and importer details. MAHLE does not accept liability for the correctness and completeness of software and data; liability for damage caused by faulty software and data is ruled out. Whatever the event, MAHLE liability is restricted to the amount for which the customer actually pays for this product. This disclaimer of liability does not apply to damages caused by intent or gross negligence on the part of MAHLE.

Warranty

Any use of non-approved hardware and software will result in a modification to our product and thus to exclusion of any liability and warranty, even if the hardware or software has in the meantime been removed or deleted.

No changes may be made to our products. Our products may only be used in combination with original accessories and original service parts. Failing to do so, will render null and void all warranty claims.

This product may only be operated using MAHLE approved operating systems. If the product is operated using an operating system other than the approved one, then our warranty obligation pursuant to our supply conditions will be rendered null and void. Furthermore, we will not be held liable for damage and consequential damage incurred through the use of a non-approved operating system.

2.3 Obligation of contractor

The contractor is obliged to ensure that all measures geared towards the prevention of accidents, industrial diseases, labor-related health risks are taken and measures towards making the workplace fit for people to work in are carried out.

Basic rules

The contractor is bound to ensure that all electrical equipment and operating material is set up, modified and maintained by skilled electricians only or under the guidance and supervision of a skilled electrician in accordance with electrical engineering principles.

Furthermore, the contractor must ensure that all electrical equipment and operating material is operated in keeping with electrical engineering principles.

If a piece of electrical equipment or operating material is found to be defective, i.e. it does not or no longer complies with electrical engineering principles, the contractor must ensure that the fault is rectified immediately and, in the event that imminent danger exists, also ensure that the electrical equipment or the electrical operating material is not used.

Tests:

- The contractor must ensure that all electrical systems and equipment are tested by a qualified electrician or under the guidance of a qualified electrician to ensure they are in proper working order:
 - Before starting for the first time.
 - After modification or repair before starting for the first time.
 - At given intervals. Set intervals such as to ensure that faults that can be expected to occur are determined in good time.
- The test is to take the electrical engineering principles relating hereto into account.
- Upon request of the trade association, a test manual is to be maintained into which specific entries are made.

2.4 Safety regulations

2.4.1 ACX1280

Always carefully study and follow all the safety regulations before using the MAHLE product.



Avoid all skin contact with the refrigerant. The low boiling point of the refrigerant (approx. $-30\text{ }^{\circ}\text{C}$) can lead to frostbite. Should refrigerant come into contact with the skin, remove any moistened clothing immediately and rinse the area of skin affected with generous amounts of water.

- Avoid all skin contact with the UV dye. Should UV dye come into contact with the skin, remove any moistened clothing immediately and rinse the area of skin affected with generous amounts of water.
- R1234yf is colorless, with weak characteristic smell and heavier than air. It may flow into repair pits. Should refrigerant escape, provide for sufficient ventilation (particularly in repair pits) and leave the workshop.



Never inhale refrigerant, dye and oil vapors. The vapors can irritate the eyes, nose and respiratory system. If liquid refrigerant or UV dye comes into contact with the eyes, rinse them thoroughly with water for 15 minutes. Then obtain medical attention even if no pain is felt.

- Never swallow UV dye. Should it be swallowed inadvertently, never attempt to induce vomiting. Drink generous amounts of water and obtain medical attention.
- Before connecting the ACX1280 to a vehicle air conditioning system or an external refrigerant bottle, make sure the quick-release couplings are not leaking. Only ever use external refrigerant bottles provided with safety valves and certified inline with the applicable standards.
- Before switching off the ACX1280, make sure all charging and drainage operations have been completed. This prevents damage to the unit and reduces risk of refrigerant escaping into the environment.



Never use compressed air with R1234yf. Certain mixtures of air and R1234yf are highly flammable. Such mixtures are a potential hazard and may lead to fire or explosions and thus cause damage or injury.

- Refrigerant extracted from a vehicle air conditioning system may be contaminated with moisture, lubricant, dirt and traces of other gases.
- The ACX1280 is provided with a refrigerant identification system designed to prevent contamination with other refrigerants.

- If the refrigerant has been contaminated by being mixed with other gases, remove the contaminated refrigerant and add fresh R1234yf before using the ACX1280 for A/C service.
- R1234yf is not to be used in areas in which there is a danger of explosion. Fire, open flames and smoking are prohibited. Welding and soldering are not permitted.
- The ACX1280 unit should not be exposed to excess moisture or be operated in wet areas.
- High temperatures and UV radiation may chemically separate R1234yf. The resultant products can cause coughing and nausea.
- R1234yf is not to be mixed with other refrigerants. The mixing of refrigerants could damage the vehicle air conditioning system.



If high-voltage components or high-voltage wires are handled incorrectly, there is a risk of fatal injury from high voltage and the possible transmission of current through the body.

- De-energizing is only to be performed by a qualified electrician, a qualified electrician for specific tasks (hybrid) or a power systems engineer.
- Work on vehicles with high-voltage components is only ever to be performed in a safe, de-energized condition by persons with the minimum qualification "Trained to perform electrical work".
- Even after deactivating a high-voltage vehicle electrical system, the high-voltage battery may still be live.
- Operating condition cannot be established from any running noise, as the electric machine is silent when stationary.
- In gear positions "P" and "N" the engine or electric motor may start spontaneously depending on the charge of the high-voltage battery.
- Never open or damage high-voltage batteries.
- On vehicles that have been in an accident, never touch high-voltage components or exposed high-voltage wires before deactivating the high-voltage vehicle electrical system.
- The ACX1280 must be constantly monitored when in operation. Never leave the ACX1280 unattended when in operation.
- Vehicle A/C service using the ACX1280 must be prepared and implemented such that the vehicle air conditioning system circuit does not have to be opened (for example by removing the radiator or engine).
- Position the ACX1280 on all four wheels on a flat, vibration-proof surface so that proper operation of the scales is guaranteed.

- The ACX1280 can be secured in position by locking the caster brake.
- The ACX1280 must always be transported in its operating position. Never lay the ACX1280 on its side, as oil could then escape from the vacuum pump or the built in compressor could be damaged.
- There are no additional safety systems for protecting the ACX1280 against damage resulting from natural catastrophes.
- Never remove any components from inside the ACX1280 except for maintenance or repair purposes.
- Follow the pertinent legal regulations or directives to ensure safe handling of pressurized devices.
- We recommend calibrating the scales at least once per year. Contact customer service for calibration of the scales.
- The ACX1280 must be subjected to regular maintenance by service personnel or authorized agents to ensure the safety of the unit.
- Disconnect power before performing any maintenance or service to unit.
- Never perform any maintenance work which is not expressly recommended in this manual. Contact customer service if components have to be replaced other than in the course of maintenance work.
- ACX1280 must be connected to a properly grounded electrical connection.
- If there is damage to the ACX1280, terminate usage immediately and contact customer service.
- The service hoses and service quick-release couplings must be regularly checked for wear and replaced if damaged.
- The ACX1280 must be operated in an environment that will provide at least four air changes per hour.
- Observe local laws or directives as to ensure the safety of the pressurized device.
- For safety reasons it is advisable to use a residual current operated circuit breaker (rccb) with the following specifications:

Parameters	Specification
Rated voltage	120 VAC ± 10 %
Rated frequency	50/60 Hz
Rated current	10 A
Rated tripping current	30 mA
Tripping switch	C

- Avoid using an extension cord with the unit. If necessary, use a good condition (three wire grounded, #14AWG or larger) extension cord of the shortest possible length. In addition, the current drawn by all devices connected to the wall socket must not exceed 15A total.

2.4.2 Refrigerant identification unit

- Inspect the outside diameter of the white sample filter element before and after each use of this unit. As soon as red spots begin to appear on any portion of the white element outside diameter, the filter requires replacement. Failure to replace the filter when so indicated may result in damage to the identification unit (out of warranty).
- This unit requires connection of the sample fitting to the LP side port of the source vehicle or refrigerant cylinder. Connection of the test hose to the high, or liquid, port of the source vehicle or refrigerant bottle will result in damage to the unit (out of warranty).
- Inspect the test hose before and after each use of the unit. Immediately replace the hose if it appears cracked, obstructed, or fouled with oil.
- Never use a test hose other than those approved for use with the Identifier.
- Never connect the Identifier to any refrigerant source that exceeds 300 psi pressure.

2.5 Safety devices

Description	Function
Air flow sensor	The ACX1280 contains an air flow sensor which detects whether or not there is a sufficient flow of air in the housing of the ACX1280.
Pressure switch	Switches the compressor off if the normal operating pressure is exceeded.
Safety valve	The safety valve opens if the design pressure is exceeded.
Circuit Breaker	Interrupts the power supply if overcurrent is applied to the ACX1280.
Vents	The ACX1280 is provided with vents in the bottom of the housing to ensure the exchange of air even when switched off.

3. Product description

3.1 Application

ACX1280 is suitable for vehicles with a conventional engine as well as for hybrid and electric vehicles. ACX1280 features all the functions required for vehicle A/C service.

The following functions can be implemented:

- Refrigerant recovery and recharging.
- Vacuum generation.
- Flushing.
- Refrigerant identification.

⚠ The ACX1280 can only be operated with R1234yf. The ACX1280 is not to be used for service work on vehicles with air conditioning systems employing refrigerants other than R1234yf, as this will cause damage. Prior to A/C service check the type of refrigerant used in the vehicle air conditioning system.

3.2 Scope of delivery

Description
Handle
Service hose (high pressure)
Service hose (low pressure)
Quick-release coupling (high pressure)
Quick-release coupling (low pressure)
Used oil bottle
Original instructions
Quick manual
Roll of paper for printer
Adapter (external bottle)
US Acme 1/2 LH
Calibration check ball
Inline filter set (2x)
Integrated refrigerant identification unit

¹⁾ May be included in delivery, depending on the version ordered

3.3 Description of unit

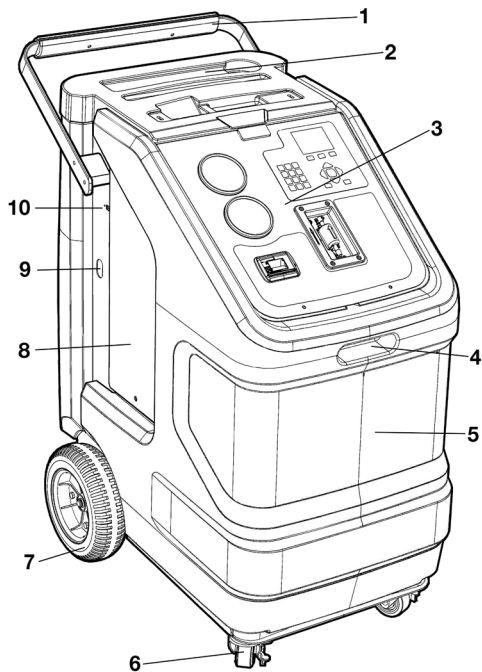

Fig. 1: Front view

- 1 Rear handle and grip
- 2 Tool tray and storage
- 3 Display and operating unit
- 4 Front handle
- 5 ACX1280 front housing
- 6 Locking caster
- 7 Rear wheel
- 8 Service door
- 9 Vacuum pump sight glass viewing window
- 10 USB port

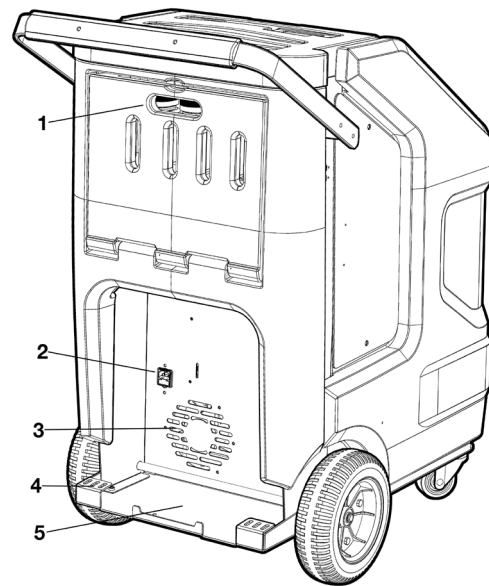

Fig. 2: Rear view

- 1 Service door for used oil and vacuum pump oil
- 2 Power supply cable inlet, circuit breaker
- 3 Fan
- 4 Kick plate
- 5 Spare refrigerant bottle/Flush device storage shelf

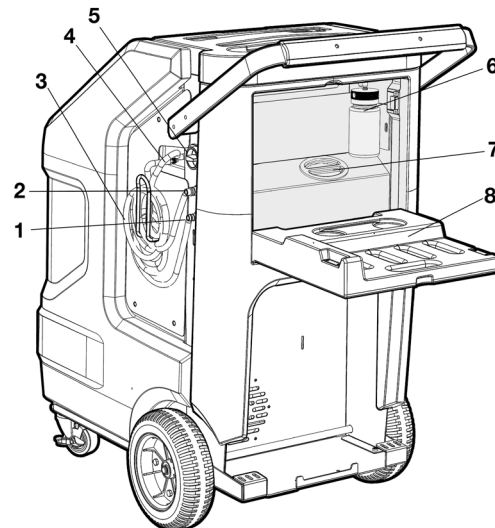

Fig. 3: Left-rear view

1. Low-side parking/flush adapter
2. High-side parking/flush adapter
3. Service hose
4. Service hose connections
5. Main switch
6. Used oil load cell and bottle
7. Vacuum pump oil fill access port
8. Service door for oil bottles and vacuum pump

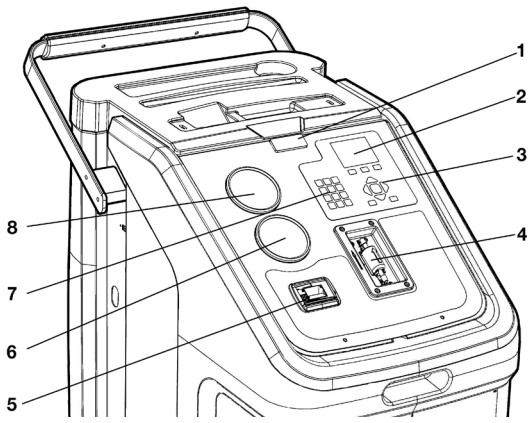

Fig. 4: Display and operating unit

- 1 Status and warning light
- 2 LCD
- 3 Selection and function keys
- 4 Refrigerant identifier
- 5 Printer
- 6 Low-pressure gauge
- 7 Input keys
- 8 High-pressure gauge

The pressure gauges (Fig. 4, Pos. 6, 8) of the display and operating unit are used to monitor the pressure during the individual vehicle A/C service phases. The status of the various service phases during maintenance is displayed on the multicolor LCD screen (Fig. 4, Pos. 2). The necessary entries are made by way of the input keys (Fig. 4, Pos. 7) on the keypad.

The selection and function keys (Fig. 4, Pos. 3) on the keypad are used to control the operator interface menu options.

The status and warning light (Fig. 4, Pos. 1) indicates the service status:

Status and warning light display color	Maintenance status
Red light	Error/warning
Flashing green	Operation in progress
Green light	Operation completed/Attention Operator

MAHLE supplies a USB stick for updating the ACX1280 software. If required, the USB stick can be inserted in the USB socket to perform updating of the firmware/software.

i Refer to Section 8.9 for detailed information on the software updating procedure.

3.3.1 Selection and function keys

Keys	Name	Function
○	OK	Confirm and store
□		Function depends on current menu
△	Back Cancel	Back one menu level or cancel
↑ or ↓		Up or down control
← or →		Right or left control
↵	Enter	Confirm and store
c	Delete	Deletes character to left of cursor
i	Information	Show current data
		Switching between number and letter input. Current mode is shown at bottom right of screen.

Various functions are assigned to the function keys in the ACX1280 software. The functions of the keys are defined in the menu line of the ACX1280 software.

3.3.2 Input keys

The input keys can be used to enter letters, numbers and special characters in the input boxes. If a key is pressed several times in succession in the input box, all the characters which can be used for this are displayed.

3.3.3 Printer

- ❗ Service reports can be printed out.
- ⚠️ Protect thermal printer paper against direct sunlight, heat, oils, greases, tanning agents and materials containing plasticizers (e.g. PVC folders).

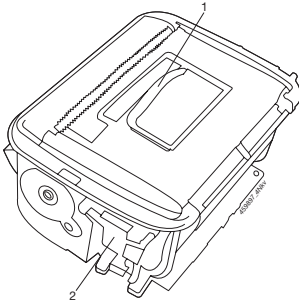

Fig. 5: Printer
1 Cover

3.3.4 Service doors

- ❗ There are two service doors: One on the left side and one on the rear of the housing.
- ❗ Tools can be placed on the upper cover.
- ❗ The service door on the side provides access to the the internal refrigerant bottle, and the filter drier.
- ❗ The service door on the rear permits access to the Vacuum pump oil fill/drain and used oil.

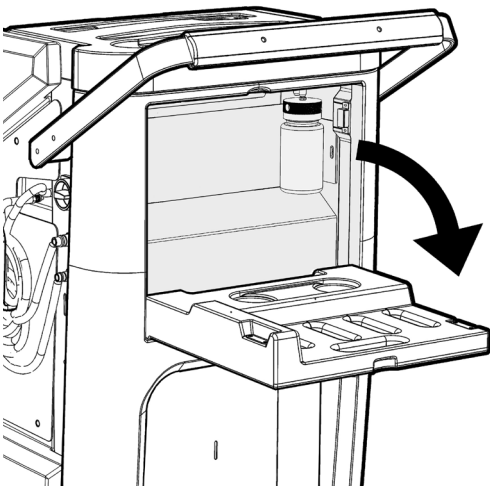

Fig. 6: Opening service door on back

To open the service door on the cover, remove the two Philips head screws and take out the service door.

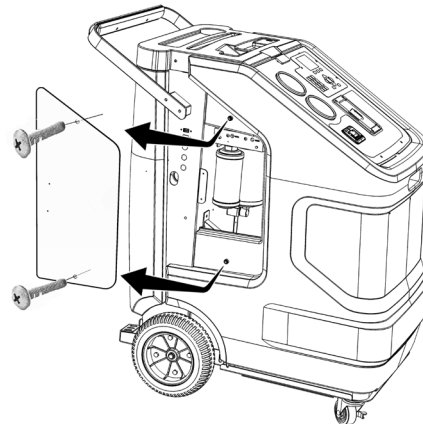

Fig. 7: Removing service door

- ⚠️ Never attempt to operate the ACX1280 without service doors, as this would make the working area dangerous. The housing of the ACX1280 was designed with a built-in ventilation fan to prevent the accumulation of potentially flammable R1234yf refrigerant vapors.

3.3.5 Scales for used oil and refrigerant

There are various scales for checking the quantities of refrigerant and used oil.

Used oil bottle

- 1 To remove the used oil bottle, pull the connection (Fig. 8) upwards slightly and detach the bottle downwards.

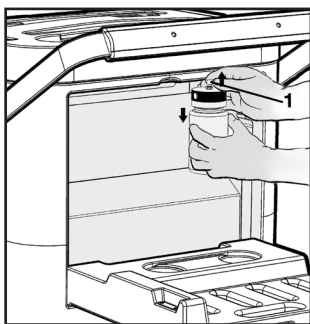

Fig. 8: Removing used oil bottle

1 Connection

Symbol	Description
	Used oil bottle

3.3.6 Service quick-release couplings

- 1 The service quick-release couplings are connected to the service connections of the vehicle air conditioning system during A/C service. When not in use, the service quick-release couplings can be connected to the parking/flush couplings.
- 1 To remove the service quick-release couplings from the parking/flush coupler, (Fig. 9), press the coupling slightly

towards the connection and carefully pull the knurled section back to unfasten it from the coupler.

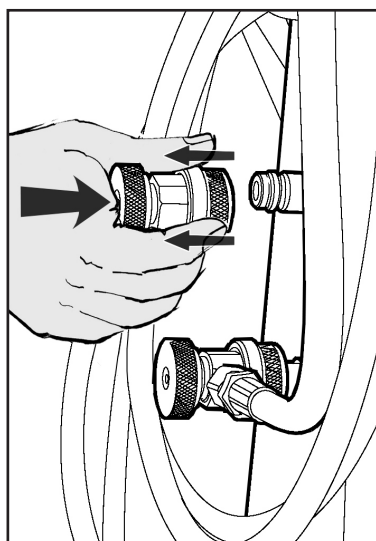
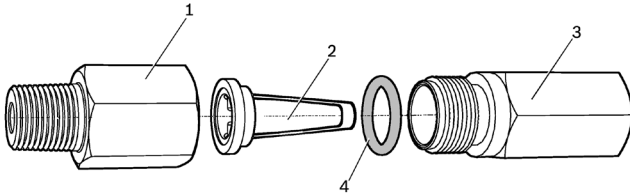

Fig. 9: Unfastening quick-release coupling

To connect the coupling, position the coupling on the parking coupler/Flush adapter, pull back the knurled section of the coupling element and press carefully onto the connection.

3.3.7 Inline filters

The service hoses are connected to the ACX1280 by way of the inline filters. The inline filters prevent the ingress of fine particles into the internal hydraulic circuit of the ACX1280.



- 1 Adapter for connection
- 2 Filter element
- 3 Adapter for hoses
- 4 Sealing ring

3.3.8 Locking caster brakes

Rolling of the ACX1280 can be prevented by locking the caster brakes (Fig. 1, Pos. 6) at the rear wheels.

3.3.9 Power supply cable and switch

The power supply cable is connected to the back of the unit. When not in operation, the power supply cable can be coiled up and set on the spare tank storage area on the back of the ACX1280.

The ACX1280 is switched on by toggling the rocker switch to the On position.

3.4 Refrigerant identification unit

The refrigerant identification unit permits precise determination of the type of refrigerant as to prevent cross contamination by other refrigerants.

⚠ Only after successful identification of refrigerant, service hoses may be connected to the vehicle.

ⓘ The refrigerant identification unit is incorporated into the service procedure and thus always to be used for A/C service.

3.4.1 Delivery

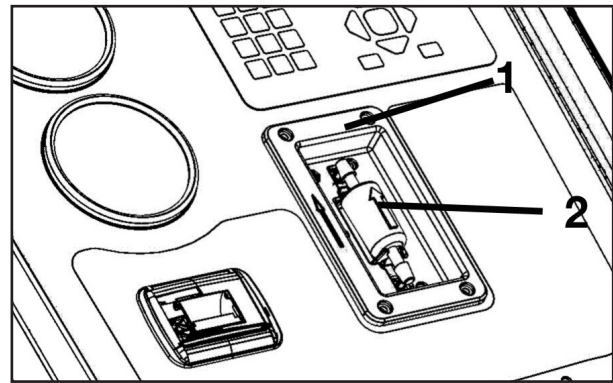

Fig. 10: Refrigerant identification unit—delivery

- 1 Refrigerant identification unit
- 2 White sample filter

3.5 Functional description

The refrigerant recovered from the air conditioning system passes through the combo filter to remove suspended particles and moisture.

The purpose of the vacuum pump is to generate a vacuum in the air conditioning system which removes excess moisture and to detect possible leaks in the vehicle air conditioning system.

Used oil separated from the vehicle refrigerant recovered drains into the used oil bottle.

Oil removed from the vehicle A/C system compressor during the recovery process should be manually injected into the A/C system prior to recharging the system.

The vehicle air conditioning system is partly filled with UV dye to facilitate the detection of leaks in the event of damage to the vehicle air conditioning system.

The refrigerant in the internal refrigerant bottle is used for filling the vehicle air conditioning system.

The purging unit for the non-condensable gases, consisting of a temperature sensor, pressure sensor, coil and orifice, always takes effect when the internal refrigerant bottle pressure is higher than the saturation pressure.

Refrigerant identification is a menu-driven process implemented by a refrigerant identification unit which is integrated into the ACX1280.

4. Commissioning

- ❗ All the operations described in Section 4 must be performed prior to first A/C service.

4.1 Removing transportation packaging

- ❗ When removing the packaging, use care to ensure there is no damage caused to the ACX1280 unit or any of the included accessories.

1. Remove the cardboard box.
2. Remove screw from metal strap at front of unit.
3. Remove screws from straps at rear of unit.
4. Remove the straps from the slots at rear of unit.
5. Using a wrench, remove the nut from the bolt at front of unit to remove metal strap.
6. Remove cardboard blocks from under ACX1280 unit.
7. Remove ACX1280 from pallet.

- ❗ Do not unplug any electrical connections and only have internal components opened and repaired by trained customer service personnel.

- ❗ Contact customer service in the event of any transportation damage (e.g. oil leakage).

4.2 Attaching handles

1. Remove plastic bubble wrap from handle.
2. Remove bolt from rear handle mounting hole (both sides of ACX1280 unit).
3. Rotate handle upwards and over top of the handle mounting spacers.

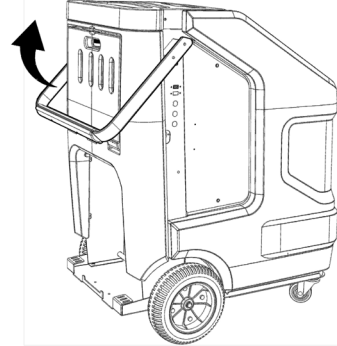

Fig. 11: Setting up handle

4. Insert the bolt on each side through handle and the spacer and tighten.

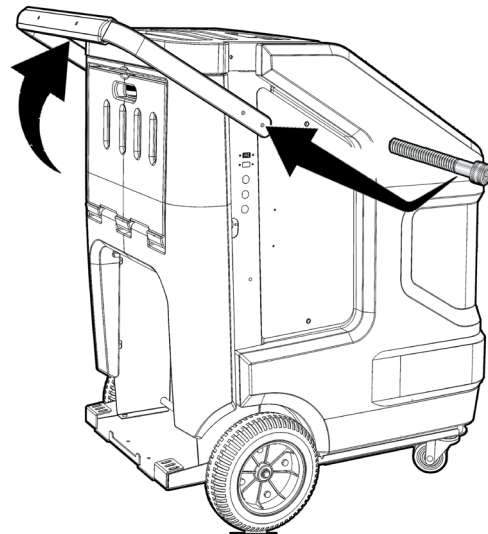

Fig. 12: Insert bolt and tighten

5. Tighten the bolt at the front side of the handle to ensure it does not come loose at a later time.

4.3 ACX1280

⚠ The ACX1280 is designed for 120 VAC ± 10 %, 50/60 Hz. Follow the information on the ACX1280 rating plate.

1. Set the ACX1280 on a flat, vibration-proof surface.
2. Actuate the caster brake to stop the ACX1280 from rolling.
3. Connect the power supply cable to the power supply.
4. Switch on the main switch.
 - ⇒ The self-test starts automatically. The menu appears following successful completion of the self-test.
 - ⇒ The fan is switched on.

❗ The fan runs while the ACX1280 is switched on.

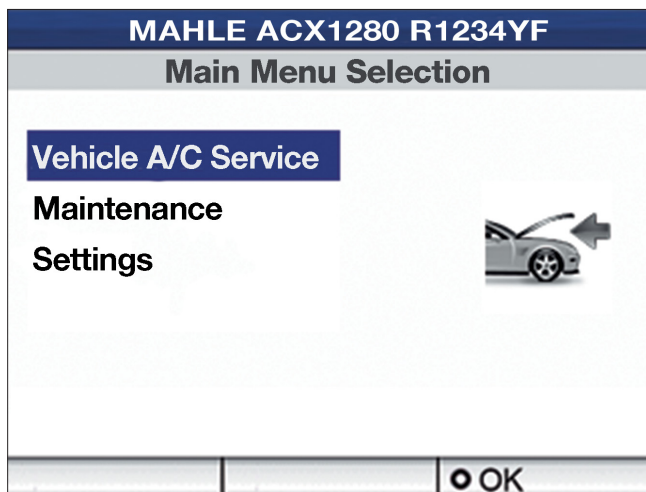

4.3.1 Setting language

1. Select "**Settings >> General settings >> Language**".
2. Select language with ↓↑.
3. Store entries with **O**.

4.3.2 Setting date and time

1. Select "**Settings >> General settings >> Date and time**".
2. Alter values with input keys.
3. Move to next value with ← →.
4. Store entries and return with **O**.

4.3.3 Setting workshop data

1. Select "**Settings >> General settings >> Workshop data**".

❗ A maximum of 30 characters can be entered.

❗ Delete values previously entered with <C>.

2. Alter values with input keys.
3. Store entries and return with **O**.

4.3.4 Activating / deactivating printer, workshop info, buzzer, operator list

1. Select "**Settings >> General settings >> System settings**".
2. Select the menu item printer, workshop info, buzzer or operator list with ↓↑.
3. Activate/deactivate with ↵.
4. Store entries and return with **O**.

Activation	Description
Operator list	An operator must be selected or a new operator entered prior to each A/C service.
Workshop info	Workshop data are printed out together with the service print-out
Buzzer	An audible alarm additionally sounds in the event of error messages.
Printer	Printer ready for operation.

4.3.5 Maximum service data records

❗ The ACX1280 stores the service data sets. The factory limit value setting for the maximum number of data sets is 400.

❗ If the number of stored data sets exceeds the limit, service can no longer be performed. Further service work is only possible after transferring the data sets to a USB stick. Password to resetting the data records is "7123493".

1. Select "**Settings >> General settings >> Maximum service data records**".
2. Alter values with input keys.
3. Store entries and return with **O**.

4.4 Checking type of connection of external refrigerant bottle

- ❗ Follow the instructions below for filling the internal refrigerant bottle.
 - **Refrigerant bottle with one valve:**
Always turn the external refrigerant bottle upside down when filling the internal refrigerant bottle.
 - **Refrigerant bottle with two valves:**
Use the adapter set to connect the service hose (LP) to the external refrigerant bottle. In doing so, turn the external refrigerant bottle such that the connections are facing upwards.
- ⚠ The internal refrigerant bottle should only be replaced if it is severely damaged. The internal refrigerant bottle must always be filled using an external refrigerant bottle.
- ⚠ During filling, the external refrigerant bottle must be firmly positioned and the operator must ensure that the service hoses are safely routed to avoid the danger of the external refrigerant bottle falling over.

4.5 Filling internal refrigerant bottle



Warning – Risk of frostbite from escaping refrigerant
Refrigerant causes severe frostbite on the skin.



- Check the service hoses for damage.
- Firmly connect the service quick-release couplings to the service hoses.



- Wear protective goggles.
- Wear protective gloves.

- ❗ Before the ACX1280 can be used, the internal refrigerant bottle must be filled with liquid refrigerant. Use only R1234yf refrigerant.
- ❗ A menu-driven refrigerant check is performed before filling the internal refrigerant bottle.
- ❗ The refrigerant can be obtained from your gas supplier. It can be stored normally and transported in bottles with connection fittings.
- ❗ To ensure a reliable procedure, it is advisable to use the optimum quantity of refrigerant. The optimum quantity of refrigerant for the ACX1280 is 4 kg – 9.5 kg.
- ❗ An inadequate quantity may make efficient filling of the vehicle air conditioning system impossible. Also, if there is an insufficient quantity, the ACX1280 may not be able to operate efficiently. In the event of an excessive quantity, there may not be sufficient space for the refrigerant recovered from the vehicle air conditioning system.
- ⚠ Generally speaking, the actual quantity of refrigerant added exceeds the set quantity by approx. 200g as there is no refrigerant in the internal refrigerant circuit. Add 200g to the set quantity when filling with refrigerant for the first time.
 1. Select "**Maintenance >> Internal bottle fill**".
 2. Follow the menu prompting.
- ❗ The current pressure inside the external refrigerant bottle is indicated on the low-pressure gauge.
- ❗ Any amount of refrigerant between 100g and 10500g can be added.
- ⚠ Do not interrupt the automatic filling process prior to automatic termination by the ACX1280.
- ❗ Press the **i** key to check the quantity of refrigerant in the internal refrigerant bottle upon completion of the filling operation.

5. A/C service preparation



Warning – Risk of burns from hot engine components

Contact with hot engine components will cause severe burns.

- Allow the engine to cool down.
- Wear protective goggles.
- Wear protective gloves.



Warning – Risk of frostbite from escaping refrigerant

Refrigerant causes severe frostbite on the skin.

- Check the service hoses for damage.
- Firmly connect the service quick-release couplings to the service hoses.
- Wear protective goggles.
- Wear protective gloves.



Perform the following preparatory work prior to vehicle A/C service:

- ⚠ Service hoses must be constructed of the proper materials and have the lengths as supplied with the unit. Hoses must have shutoff devices (quick-release couplers) at the connection point to the A/C to minimize the introduction of air into the ACX1280 and to minimize the amount of refrigerant released while disconnecting the hoses.
- ⚠ Inspect hoses for signs of damage prior to performing A/C service. Use of damaged hoses will result in the loss of refrigerant and the possibility of refrigerant contamination.

- ⓘ Follow the vehicle manufacturer's recommendations for A/C service on vehicles with a low-pressure connection only.

1. Set the ACX1280 on a flat, vibration-proof surface.
2. Actuate the caster brake to stop the unit from rolling.
3. Connect the power supply cable to the power supply.
4. Switch on the main switch.

- ⓘ Follow the manufacturer's instructions for the corresponding vehicle before performing A/C service.

- ⚠ The ACX1280 is only to be operated with R1234yf refrigerant. Check which refrigerant is used for the vehicle before performing A/C service.

- ⚠ The ACX1280 cannot be used for air conditioning systems repaired using a chemical sealant. These sealants may cause serious damage to the ACX1280 if they are present. Detection devices are available to check for chemical sealants. Non compliance will void the warranty.

- ⚠ Never attempt to close the valves of the internal refrigerant bottle while the ACX1280 is in operation.

- ⚠ Only new lubricant, as specified by the system manufacturer, shall be installed in the MAC system. Lubricant removed from the system and/or equipment shall be disposed of in accordance with the applicable federal, state, and local procedures and regulations.

6. Operation

⚠ *Before connecting service hoses proceed as follows:*

1. Perform refrigerant identification (see chapter 6.3).

6.1 Service phases

- **Recovery phase:** Refrigerant is extracted from the vehicle, cleaned and routed into the internal refrigerant bottle.
- **Vacuum phase:** A vacuum is generated in the vehicle air conditioning system and the system is checked for leaks.
- **Recharge phase:**
 - Refrigerant: The vehicle air conditioning system is filled with a specified amount of R1234yf refrigerant.

6.2 My database

📘 Perform the following steps to add a new vehicle to the operator-defined (direct parameter input) database or to make changes or deletions.

1. Select "**Settings >> My database**".
2. Select vehicle with ↑↓.
3. Press **■**.
4. Alter values with input keys.
5. Store entries and return with **○**.

6.3 Refrigerant identification unit

6.3.1 Refrigerant analysis

⚠ Oil contamination will damage the refrigerant identification unit! If the refrigerant sample is supplied to the unit from the recycling equipment directly, it must be protected from oil that comes from vehicles or accumulate in service hoses!

⚠ The operator must periodically examine the test hose and white sample filter for oil contamination and stop immediately if any oil is observed!

📘 The gas pressure should be between 1.7 –16 bar. Accurate gas analysis can be achieved with less than 1.7 bar but additional time must be provided. In this case start the flow of gas and then wait for 20 seconds before instructing the refrigerant identification unit to test the gas.

1. Switch on the ACX1280.
2. Select "**Vehicle A/C service >> Refrigerant identification**".
3. Follow the menu prompting of ACX1280.

📘 Getting message "Sample not OK", check for contamination of the test hose, then repeat the procedure up to 2 times.

📘 Getting message "Sample not OK" for three times, a refrigerant verification must be performed.

6.3.2 Decontamination

❶ Perform the following steps to remove contaminated refrigerant from the service hoses and couplers.

1. Select "**Maintenance >> Maintenance >> Decontamination**" or process continues automatically after 3 failed identifications.
2. Switch off the ACX1280 unit.
3. Disconnect power cord from outlet.
4. Move unit outside.
5. Connect High and Low side couplers to the Parking/Flush adapter and open valves to equalize pressure.
6. Close Low side coupler and remove from Parking/Flush adapter.
7. Connect Low side tank adapter to low side coupler.
8. Pointing adapter away from unit and person, slowly open valve until low pressure gauge shows 0 bar(g).
9. Close low side coupler and remove Low side tank adapter.
10. Connect low side coupler to the Parking/Flush adapter and open valve. Pressure on HP gauge should go down.
11. Close low side coupler and disconnect from parking/flush adapter
12. Repeat steps 5-11 until both gauges read 0 bar(g).

❶ This process may need to be repeated a number of times depending on the amount of pressure inside the hoses.

13. After all pressure has been released, connect low side coupler to Parking/flush adapter and open valve.
14. Connect power to the unit.
15. Switch on the ACX1280 unit.
16. Follow the menu prompting.

❶ If getting message "High Pressure in System" which appears after decontamination process begins, pressure has not been relieved from hoses properly. Repeat above steps starting at 5 to remove error above.

❶ Following the Decontamination routine, a Refrigerant verification should be performed.

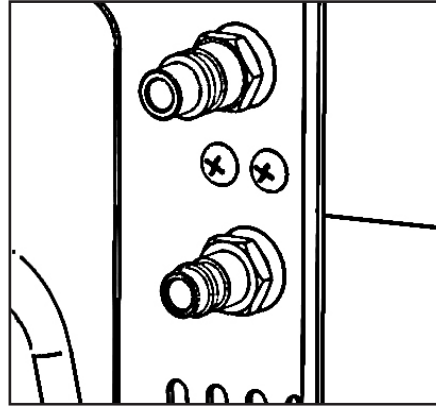

Fig. 13: High low flushing adapter / Parking coupler

6.3.3 Refrigerant verification

❶ Connect refrigerant identification unit to an external R1234yf bottle with pure R1234yf.

1. Select "**Vehicle A/C Service >> Refrigerant Identification.**".
2. Follow the menu prompting.

❶ Contact customer service after not passed analysis for 3 times.

6.4 Automatic A/C service

⚠ Before connecting service hoses proceed as follows:

1. Perform refrigerant identification (see chapter 6.3).
- ⚠ Only after successful identification of refrigerant, service hoses may begin on the vehicle.
- ❗ The contamination of the service hoses on the ACX1280 unit can only be removed by following the decontamination process (see Chapter 6.3.2).
 - ❗ The contamination of the ACX1280 internal bottle can only be removed by a service provider at additional cost.
 - ❗ The service parameters (recharge quantity) can be found in the owner's manual or the vehicle repair manual.
 - ❗ The refrigerant identification unit is incorporated into the service procedure and required to be used for A/C service.

1. Select "**Vehicle A/C service >> Automatic A/C service**".
2. Select
 - Direct parameter input (alteration of service parameters) or
 - Select last 10 vehicles or
 - My database.
3. Follow the menu prompting.

6.5 Manual A/C service

⚠ Before connecting service hoses proceed as follows:

1. Perform refrigerant identification (see chapter 6.3).
- ⚠ Only after successful identification of refrigerant, service hoses may be connected to the vehicle.
- ❗ The contamination of the service hoses on the ACX1280 unit can only be removed by following the decontamination process (see Chapter 6.3.2).
 - ⚠ The contamination of the ACX1280 internal bottle can only be removed by a service provider at additional cost.
 - ❗ The service parameters (recharge quantity) can be found in the owner's manual or the vehicle repair manual.
 - ❗ The refrigerant identification unit is incorporated into the service procedure and required to be used for A/C service.

1. Select "**Vehicle A/C service >> Manual A/C service**".
2. Follow the menu prompting.

- ❗ All service phases can be implemented manually with the ACX1280.
- ❗ R1234yf can only be added to an air conditioning system in which there is a vacuum. The vacuum phase must therefore be implemented before filling with R1234yf.

6.6 Automatic/manual vehicle A/C service overview

Phases	Automatic mode	Manual mode		
		Recovery	Vacuum	Recharge
Checking of air conditioner pressure	x	x	x	x
Extraction of refrigerant	x	x	-	-
Separation of oil from refrigerant	x	x	-	-
Formation of vacuum	x	x	x	x
Maintenance of vacuum	x	x	x	x
Addition of refrigerant (test quantity 15% of total recharge quantity)	x	-	-	x
Extraction of refrigerant (test quantity 15% of total recharge quantity)	x	-	-	x
Implementation of leak test	x	-	-	x
Pressure increase test	x	x	-	-
Drainage of oil into used oil bottle	x	x	-	-
Pressure build-up	x	-	-	x
Recharging refrigerant	x	-	-	x

Tab. 1: Automatic/manual mode overview
x = is implemented

6.6.1 Recovery

The pressure in the vehicle air conditioning system is checked prior to the recovery phase. The vacuum phase commences automatically if the air conditioning system is depressurized (empty).

6.6.2 Vacuum

- A vacuum is generated and maintained for at least 5 minutes.
- Make sure recovery has been performed before generating the vacuum.

6.6.3 Charging with refrigerant

- Service phases:** Vacuum, Vacuum hold, 15% of total charge test fill, leak test, extraction of test fill, pressure increase test, and final charging.
- If pressure is detected in the vehicle air conditioning system during charging, recovery must be performed in order to continue.

6.7 Flushing after changing type of oil

When servicing a vehicle, the type of oil in the vehicle's A/C system should be noted to prevent a cross-contamination inside the ACX1280. If a PAG system is serviced and another vehicle with a POE system is to be serviced next, a flush routine must be performed to prevent a cross-contamination of the oils.

If the ACX1280 is not flushed, the internal hydraulic system and the vehicle air conditioning system could be damaged as a result of cross-contamination. MAHLE cannot accept liability for any such damage.

Enter the parameters for vacuum time and refrigerant quantity.

- Select "**Vehicle A/C service >> A/C system flushing >> Short flushing**".
- Follow the menu prompting.

The short flushing procedure is used to clear out the ACX1280 hoses when changing oil types. The Extended Flushing procedure is used to perform liquid refrigerant flushing on A/C system components.

6.8 Draining service hoses

- Select "**Maintenance >> Hose drain**".
- Follow the menu prompting.

6.9 Setting service parameters

- Select "**Settings >> A/C service parameters**".
- Alter the parameters with the input keys.

The parameters can be pre-set at the start of the corresponding service phase in manual and automatic A/C service.

Service parameters	Automatic vehicle A/C service	Manual vehicle A/C service		
		Recovery	Vacuum	Recharge
Vacuum time	x	-	x	-
Vacuum hold time	x	-	-	-
R1234yf refrigerant	x	-	-	x

Tab. 2: Setting parameters

Used oil must be disposed of in accordance with local regulations!

6.10 Non-condensable gases

- ❗ Purging takes place automatically in the ACX1280 on the basis of a pressure and temperature algorithm. The purged non-condensable gases are routed to the built-in ventilation fan and removed from the ACX1280.

6.11 System leak test

- ❗ The ACX1280 performs a system leak test to check that none of the components carrying refrigerant are leaking. After 68kg (150lbs) of refrigerant has been processed, after combo filter replacement or after 60 hours of vacuum time, the operator is requested to perform a "system leak test". The operator can conduct a "system leak test" at any time on completion of a process phase.
- ❗ The system leak test takes roughly 30 minutes.
- Select "**Maintenance >> System leak test**".
- ➔ The leak test process is started.

The following action must be taken if the system leak test is unsuccessful:

1. Check the service hoses and filter connections for leaks.
 2. The valves of the service quick-release couplings must be closed.
 3. Repeat the system leak test.
- ❗ Contact customer service if the system leak test is again unsuccessful.

7. Troubleshooting

i Please contact customer service if any of the actions suggested in this Section cannot be implemented.

7.1 ACX1280

Error code	Messages	Action
100A	RECOVERY: Leak detected.	<ul style="list-style-type: none"> • Check A/C system and unit for leaks.
1001	RECOVERY: Service timeout.	<ul style="list-style-type: none"> • Check inline filters.
1002	RECOVERY: High pressure shutdown.	<ul style="list-style-type: none"> • Contact customer service.
1003	RECOVERY: Used oil bottle full.	<ul style="list-style-type: none"> • Empty used oil bottle. • Reset scales.
1004	RECOVERY: Internal refrigerant cylinder full.	<ul style="list-style-type: none"> • Weight limit reached. Reduce quantity of refrigerant in internal refrigerant cylinder. • Check scales.
1005	RECOVERY: Used oil bottle not found.	<ul style="list-style-type: none"> • Check used oil bottle connection.
1009	RECOVERY: Low pressure detected in vehicle.	<ul style="list-style-type: none"> • Vacuum creation.
2001	VACUUM CREATION: High pressure detected in vehicle.	<ul style="list-style-type: none"> • Perform recovery process.
2002	VACUUM CREATION: Leak detected	<ul style="list-style-type: none"> • Use a UV lamp to search for leaks in the vehicle air conditioning system.
2003	VACUUM CREATION: Service timeout	<ul style="list-style-type: none"> • Check for clogging of service hoses. • Check scales.
5001	RECHARGE: Service timeout.	<ul style="list-style-type: none"> • Check for clogging of ACX1280. • Check whether the valves of the quick-release couplings are open.
5002	RECHARGE: Insufficient refrigerant quantity.	<ul style="list-style-type: none"> • Perform Internal Cylinder Fill process. • Optimum quantity of R1234yf is 4 kg – 9.5 kg.
5003	RECHARGE: Charging unsuccessful.	<ul style="list-style-type: none"> • Check whether the valves of the service quick-release couplings are open. • Check for clogging of service hoses. • Charge the internal refrigerant cylinder.
5004	RECHARGE: High pressure shutdown.	<ul style="list-style-type: none"> • Check whether the valves on the internal refrigerant cylinder are open. • Check for clogging of service hoses.
5005	RECHARGE: Refrigerant cylinder full.	<ul style="list-style-type: none"> • Weight limit reached. Reduce quantity of refrigerant in internal refrigerant cylinder. • Check scales.
5006	RECHARGE: High pressure in vehicle. Perform recovery.	<ul style="list-style-type: none"> • Perform recovery process.
9102	FACTORY SETTING: Not completed.	<ul style="list-style-type: none"> • Complete all vehicle information.
9201	SYSTEM ERROR: No USB detected.	<ul style="list-style-type: none"> • Check whether USB stick is connected to USB connection.
9300	SELF-TEST UNSUCCESSFUL: View detail.	<ul style="list-style-type: none"> • View details. • Take corrective action to rectify error.
9600	PRINTER: No paper in printer.	<ul style="list-style-type: none"> • Check for paper in printer.
A101	INTERNAL BOTTLE FILL: Time elapsed.	<ul style="list-style-type: none"> • Check for clogging of ACX1280.
A103	INTERNAL BOTTLE FILL: Refrigerant cylinder full.	<ul style="list-style-type: none"> • Weight limit reached. Reduce quantity of refrigerant in internal refrigerant cylinder. • Check scales.
A104	INTERNAL BOTTLE FILL: High pressure shutdown.	<ul style="list-style-type: none"> • Check whether the valves on the internal refrigerant cylinder are open. • Check for clogging of service hoses.
A105	INTERNAL BOTTLE FILL: Low pressure.	<ul style="list-style-type: none"> • Check whether the valves on the external refrigerant cylinder are open. • Check for clogging of service hoses.
A202	SHORT FLUSHING: Service timeout.	<ul style="list-style-type: none"> • Check for clogging of ACX1280.

Error code	Messages	Action
A203	SHORT FLUSHING: Insufficient refrigerant quantity.	<ul style="list-style-type: none"> • Charge the internal refrigerant cylinder.
A204	SHORT FLUSHING: Leak detected.	<ul style="list-style-type: none"> • Repair vehicle air conditioning system or part being flushed.
A205	SHORT FLUSHING: High pressure shutdown.	<ul style="list-style-type: none"> • Check low-pressure valve at internal refrigerant cylinder. • Check for clogging of service hoses.
A206	SHORT FLUSHING: High pressure in vehicle.	<ul style="list-style-type: none"> • Perform recovery if pressure is above 0.6 bar. • Generate vacuum if pressure is 0.6 bar.
A208	SHORT FLUSHING: Refrigerant cylinder full.	<ul style="list-style-type: none"> • Weight limit reached. • Reduce quantity of refrigerant in internal refrigerant cylinder. • Check scales
A209	SHORT FLUSHING: Charging unsuccessful.	<ul style="list-style-type: none"> • Check for clogging of service hoses.
A302	EXTENDED FLUSHING: Service timeout.	<ul style="list-style-type: none"> • Check for clogging of ACX1280.
A303	EXTENDED FLUSHING: Insufficient refrigerant quantity.	<ul style="list-style-type: none"> • Charge the internal refrigerant cylinder.
A304	EXTENDED FLUSHING: Leak detected.	<ul style="list-style-type: none"> • Check for leak at part just being flushed.
A305	EXTENDED FLUSHING: Deactivate high pressure.	<ul style="list-style-type: none"> • Check for clogging of ACX1280.
A306	EXTENDED FLUSHING: High pressure in vehicle.	<ul style="list-style-type: none"> • Pressure is above 0.6 bar during extraction. • Perform recovery.
A307	EXTENDED FLUSHING: Used oil bottle full.	<ul style="list-style-type: none"> • Empty used oil bottle. • Reset scales.
A308	EXTENDED FLUSHING: Refrigerant cylinder full.	<ul style="list-style-type: none"> • Weight limit reached. Reduce quantity of refrigerant in internal refrigerant cylinder. • Check scales. • Replace scales.
A309	EXTENDED FLUSHING: Charging unsuccessful.	<ul style="list-style-type: none"> • Check for clogging of service hoses.
A701	CALIBRATION CHECK: Weight not attached.	<ul style="list-style-type: none"> • Attach calibrating weight.
A702	CALIBRATION CHECK: Failed.	<ul style="list-style-type: none"> • Perform calibration again.

7.2 Refrigerant identification unit

Error code	Messages	Action
D000	Sample NOK	<ul style="list-style-type: none"> • Move the unit away from sources of EMF or RFI such as radio transmitters and arc welders • Repeat refrigerant analysis
D001	Air or gas reading was unstable	<ul style="list-style-type: none"> • Move the unit away from sources of EMF or RFI such as radio transmitters and arc welders • Repeat refrigerant analysis
D002	Air or gas reading was excessively high	<ul style="list-style-type: none"> • Prevent refrigerant from flowing into the unit through the sample inlet during air calibration • Allow any refrigerant in the atmosphere to dissipate before performing air calibration • Repeat refrigerant analysis
D003	Air calibration resulted in low output	<ul style="list-style-type: none"> • Move the unit to an area where the ambient temperature is within the specified operating range • Repeat refrigerant analysis
D004	Unit is beyond temperature range	<ul style="list-style-type: none"> • Repeat refrigerant analysis
D005	Excessive air or little or no sample flow	<ul style="list-style-type: none"> • Verify the coupler valve is open • Repeat refrigerant analysis • Verify the sample filter is not plugged with debris or oil. • Replace brass sample filter
D006	Internal error	<ul style="list-style-type: none"> • Retry Operation. Contact tech-support if problem persists
D007	User abort	<ul style="list-style-type: none"> • Repeat refrigerant analysis
D008	Communication error	<ul style="list-style-type: none"> • Check USB connection

8. Maintenance

8.1 Maintenance interval

Description	Period
Calibration of scales	1 x per year
Vacuum pump oil replacement and system leak test	After 60 hours of service
Inline filter replacement	Refer to filter drier
Combo filter replacement and system leak test	After 68kg (150lbs) of refrigerant processed
System leak test	As required
White sample filter of refrigerant identification unit	As soon as red spots begin to appear on any portion of the white element

⚠ Never perform any maintenance work which is not expressly recommended in this Section.

⚠ Contact customer service if components have to be replaced other than in the course of maintenance work.

8.2 Maintenance protocol

- ❗ The ACX1280 stores various protocols which can be printed out.
 - Last 3 system service reports.
 - Self-test report
 - Refrigerant report
 - Error report
 - Operating hour meter

1. Select "**Maintenance >> Service report**".
2. Select protocol with ↓↑ and ↵.
3. Print protocol.

8.3 Calibration of scales

8.3.1 Calibrating internal refrigerant bottle

❗ The internal refrigerant bottle is calibrated at the factory.

1. Select "**Maintenance >> Maintenance >> Calibration >> Scale calibration**".
2. Enter the password "227".
3. Select the scale.
4. Select **0**.
5. Enter the weight.
6. Attach the calibrating weight.
7. Select **0**.
- ➔ Calibration completed.
8. Select **0**.
9. Remove the calibrating weight.

8.3.2 Calibrating used oil bottle scale

1. Select "**Maintenance >> Maintenance >> Calibration >> Scale Calibration**".
2. Enter the password "227".
3. Select the used oil scale.
4. Remove the bottle.
5. Select **0**.
6. Attach the calibrating weight to the scales selected.
7. Enter the weight.
8. Select **0**.
- ➔ Calibration completed.

8.4 Calibration check

❗ Only internal refrigerant bottle.

1. Select "**Maintenance >> Maintenance >> Calibration >> Calibration check**".
2. Select the scale.
3. Attach the calibration check ball.
4. Select **0**.
- ➔ Calibration check completed.

❗ Getting message "calibration check failed", calibration check should be performed again and if it still fails a second time, a calibration of the internal refrigerant bottle scale should be performed.

8.5 Taring of Scales

❗ Only applies to used oil bottle scale.

1. Select "**Maintenance >> Maintenance >> Calibration >> Tare reset**".
2. Select the scale.
3. Attach an empty bottle.
4. Select **0**.
- ➔ Tare reset completed.

8.6 Replacing inline filters

- ❗ The inline filters must always be changed when replacing the filter drier.

The inline filters consist of a filter element fitted in the hose adapter.

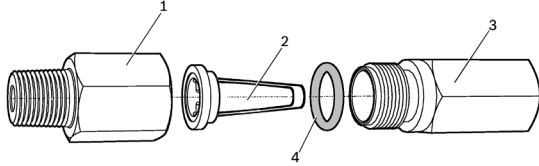

- | | |
|--------------------------|---------------------|
| 1 Adapter for connection | 3 Adapter for hoses |
| 2 Filter element | 4 Sealing ring |

1. Drain the service hoses.
2. Disconnect the service hoses from the inline filters.

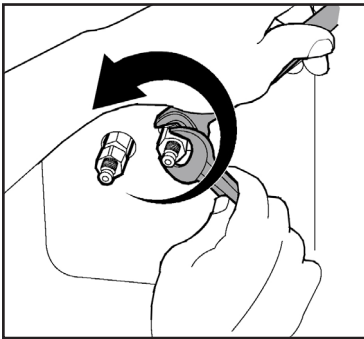

Fig. 14: Removing adapter

3. Remove the filter element.
4. Install the new filter element.

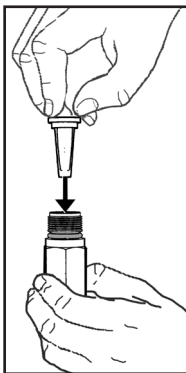

Fig. 15: Installing filter element

- ❗ Make sure the sealing ring is correctly positioned at the adapter and not damaged. Replace the sealing ring if it is damaged.

5. Screw the inline filter onto the adapter.
6. Attach the service hoses to the adapter.

8.7 Vacuum pump

8.7.1 Changing vacuum pump oil



Attention – Risk of burns from hot surfaces

Contact with the hot surface of the vacuum pump will cause severe burns.



- Allow the vacuum pump to cool down.
- Wear protective gloves.

- ❗ The vacuum pump oil must be changed after 60 hours of operation. The message "Change vacuum pump oil" appears on the screen when the vacuum pump oil needs changing.

- ❗ Use the vacuum pump oil specified by MAHLE (part number 360 82946 00).

1. Place a container under the drain on back side of unit.
2. Open rear service door and pull plug to expose oil fill port.
3. Open the drain plug and filler plug of the vacuum pump.
4. Drain all the oil.
5. Close the drain plug.
6. Pour vacuum pump oil into oil fill port until oil level is somewhere between the min and max lines.
7. Turn on unit and start a vacuum process.
8. Check oil level .

- ❗ Oil level is accurate when level is midway between full and empty.

➔ Oil change completed.

8.7.2 Resetting oil change interval

1. Select "**Maintenance >> Service Report >> Statistics >> Vac. pump oil life**".

- ❗ The time since the last oil change is displayed.

2. Enter the password "227".
 3. Store entries and return with **O**.
- ➔ Oil change interval reset.

8.8 Combo filter

8.8.1 Changing Combo-Filter



Warning – Risk of frostbite from escaping refrigerant

Refrigerant causes severe frostbite on the skin.



- Check the service hoses for damage.
- Firmly connect the service quick-release couplings to the service hoses.



- Wear protective goggles.
- Wear protective gloves.

i Unit operation is disabled at the end of the filter service life. Each filter is marked with a unique code. This code must be entered when replacing the filter. It is not possible to operate the ACX1280 if the same code is re-used. It is advisable to keep a supply of filters in stock to avoid downtimes due to the unit being disabled.

i The ACX1280 is disabled once 68kg (150lbs) of R1234yf refrigerant have passed through the filter. A new filter must be installed and its unique code entered in the ACX1280 before vehicle A/C service can be performed.

i The message "Filter replacement due" appears once 57kg (125lbs) of refrigerant have passed through the filter. As soon as this warning message is displayed, contact customer service to order a new filter. The contact data can be found on the rating plate.

⚠ Pay attention to correct positioning of the two O-rings when fitting a new filter!

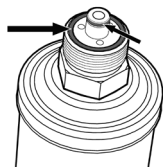

Fig. 16: O-Rings

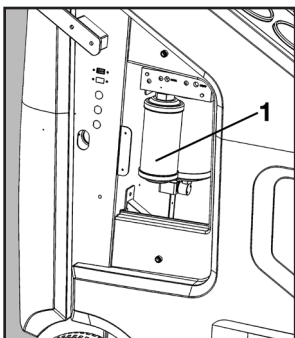

Fig. 17: Replacing filter

1. Combo filter



Fig. 18: Location of PIN number on filter

1 Code

1. Drain the service hoses.
2. Remove the right service door.
3. Loosen the filter, using a 1-3/8" (35 mm) wrench.
4. Remove the filter.

i Make sure the old sealing rings are removed before securing the new filter.

5. Insert a new filter.
6. Tighten the filter to 74 ft-lbs (100 N-m).
7. Secure the service door.

⚠ Take care not to damage any hoses or electrical connections when changing the filter.

⚠ Never re-use an old filter.

8.8.2 Resetting filter replacement interval

1. Select "**Maintenance >> Service Report >> Statistics >> Filter Drier Life**".
 2. Enter the 16-position PIN number of the new filter.
 3. Store entries and return with **O**.
- ➔ The leak test process is started.

8.9 Software update

- ❗ The firmware (software) can be updated by way of a USB stick.
 - ❗ The scales must be recalibrated after a firmware update.
1. While powering on the ACX1280 unit, press and hold the "8" key. Release key when the display shows "**Firmware Update**" in the lower left corner.
 2. When the Firmware update screen loads, it will ask the user to "Please insert Update Disk."
 3. Insert USB disk into lower right hand corner of the control panel. After a few moments, the screen will change and instruct the user to press the "△" key to update the unit.
 4. Once user presses the "△" key, the screen will have a status bar that appears at the bottom as the software loads. This process can take several minutes.
 5. After completion the unit will confirm the update has completed. At this time, remove the USB drive and turn off power to the unit.
 6. The next time the unit is turned on, it should display the new software version in the lower left corner of the screen.

8.10 Replacing printer paper

⚠ Avoid excessive force as not to damage the lever.

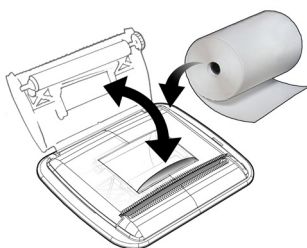

1. Pull the printer lever until the cover is released.
2. Change the roll of paper.
3. Close the cover.

8.11 Replacing white sample filter (Refrigerant identification unit)

⚠ The need to replace the white sample filter may indicate oil contamination in the test hose. Replace the test hose if oil entrapment is found.

1. Switch off the ACX1280 unit.
2. Remove existing filter by pulling it straight out of the retaining clip.
3. Discard the used filter.

❗ Align the arrow on the filter with the arrow on the unit.

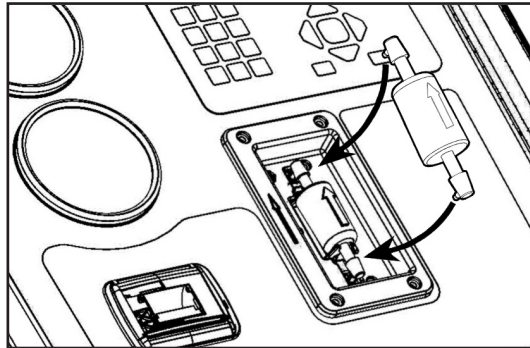

4. Position the filter into its retaining clip on the unit case.
5. Remove the 4 screws that attach the plastic tool tray.
6. Remove the 2 screws that attach the front display unit.
7. Carefully open the front display. NOTE: This step may require operator to loosen the 2 locking-nuts at the pivot point to be able to open the display.
8. Once unit is open, inspect clear hose coming from back side of identifier down to solenoid assembly mounted on the center panel.
9. Replace if necessary.
10. Fold display down and install 2 screws to front plastic.
11. Tighten locknuts at pivot point if they were loosened.
12. Reinstall tool tray and the 4 screws.

8.12 Resetting the circuit breaker.

1. Switch off the ACX1280 and unplug from receptacle.
2. Allow unit to sit for a minute.
3. Look above fan on back of unit for the white button
4. Press white circuit breaker button back in to reset.
5. Plug in unit and turn back on.

8.13 System information

❗ The following items of system information can be displayed when pressing the **i** key.

Display	Description
PSA	Pressure sensor/accumulator
PSV	Pressure sensor/vacuum (service hoses)
PST	Pressure sensor/internal refrigerant bottle
Refrigerant	Quantity in internal refrigerant bottle
Used oil	Quantity in used oil bottle
Tank-Temp.	Temperature/internal refrigerant bottle
Amb.-Temp.	Ambient temperature

8.14 Service Report

❗ The ACX1280 unit tracks the quantity of refrigerant processed and requests a reset after January 1 of each calendar year. To perform this reset, the password required is "73738".

8.15 Spare and wearing parts

8.15.1 ACX1280

Description	Order number
Replacement combo filter	360 82739 00
Vacuum pump oil	360 82946 00
Roll of paper for printer	360 82947 00
Service hose (HP)	360 82948 00
Service hose (LP)	360 82949 00
Quick-release coupling (HP)	360 82950 00
Quick-release coupling (LP)	360 82951 00
Used oil bottle	360 82741 00
Service Kit (vacuum pump oil, o-rings, inline filter, ID-filter)	360 82740 00
Operation manual	035 82219 00
Quick reference guide	035 82220 00
Adapter (external bottle) US ACME 0,5"	360 82953 00
1 kg calibrating weight for used oil calibration	360 82735 00
4 kg calibrating weight for internal ref. bottle	360 82734 00
Calibration check ball	360 82744 00
Inline filter set (10 x)	360 81618 00
Dust cover (accessory item)	026 80687 00
Leak detector R1234yf (accessory item)	026 80635 00
Safety goggles (accessory item)	360 82956 00
Protective gloves (accessory item)	360 82957 00

8.15.2 Refrigerant identification unit

Description	Order number
Refrigerant identification unit	360 82944 00
White sample filter	360 82958 00

9. Disposal

9.1 Disposal of electronic parts



This product is subject to the European directive 2002/96/EC (WEEE).

Old electrical and electronic devices, including cables, accessories and batteries, must be disposed of separately from household refuse.

- Please make use of the return and collection systems operating in your region.
- Proper disposal of old devices can help to avoid environmental pollution and health risks.

9.2 Disposal of LCD screen

Please dispose of the LCD screen in accordance with the local regulations governing the disposal of hazardous waste.

9.3 Disposal of refrigerants, UV dye, lubricants and oils

Refrigerants which can no longer be used must be returned to the gas supplier for disposal.

The lubricants and oils removed from air conditioning systems must be returned to official collection points. The UV dye must always be disposed of in accordance with the local regulations governing the disposal of hazardous waste.

9.4 Disposal of combo filter

Dispose of the filter via official collection points or in accordance with the local regulations.

10. Technical data

10.1 ACX1280

Feature	Value/Range
Dimensions H x W x D	1016 x 580 x 840 mm
Weight	110 kg
Operating voltage	120 VAC ± 10 %
Frequency	50/60 Hz
Workplace emission sound pressure level (as per EN ISO 11204)	< 70 dB(A)
Refrigerant	R1234yf
Pressure sensor	0 bar
Pressure sensor	0 bar – 34.5 bar
Pressure sensor	0 bar – 10.3 bar
Low-pressure gauge	-1 bar – 16 bar ± 1 % of final value
High-pressure gauge	-1 bar – 40 bar ±1 % of final value
Capacity of internal refrigerant bottle	10.5 kg
Maximum system pressure PS	20 bar
Pspec	18 bar
Power	900 W
Operating temperature	10°C – 50°C
Optimum R1234yf filling weight for operation	4 kg – 9.5 kg

- i** The ACX1280 conforms to the low voltage directive (LVD).

10.2 Refrigerant identification unit

Feature	Value/Range
Refrigerant	R1234yf
Measurement accuracy	98.5 % ± 0.5 %
Sensor	Optical (infrared)
Operating temperature	10°C – 50°C

10.3 Electromagnetic compatibility

This product complies with the standards EN 61000-6-2 and EN 61000-6-4.

11. Glossary

- **Recovery phase:** The refrigerant is extracted from the vehicle air conditioning system, cleaned and routed into the internal bottle of the ACX1280. The refrigerant oil collected in the process is drained into the used oil bottle at the ACX1280.
- **Vacuum phase:** A vacuum is generated in the vehicle air conditioning system. Measurement of the drop in pressure begins as soon as the vacuum has been generated.
- **Charging phase:** A certain quantity of refrigerant is added to the vehicle air conditioning system.

12. Notes

MAHLE

MAHLE Aftermarket Inc.

10 Innovation Drive
York, PA 17402
USA

717-840-0678

www.servicesolutions.mahle.com

035 82219 00
2014-10-31