

MAHLE AFC-9 & CFC-16

EN

Operation Manual
Container Crusher

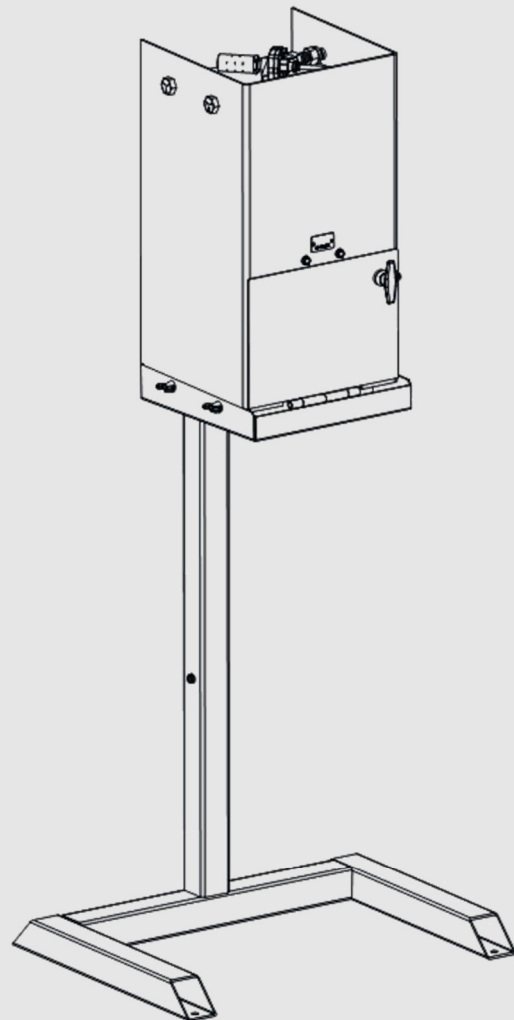



**EVERY PERSON WHO OPERATES THIS
EQUIPMENT NEEDS TO KNOW AND
UNDERSTAND ALL OF THE INFORMATION IN
THIS MANUAL – FAILURE TO DO SO COULD
RESULT IN SERIOUS INJURY OR DEATH.**

**READ THIS MANUAL
CAREFULLY AND
RETAIN FOR YOUR
RECORDS**

Contents

1. Safety Regulations	4
1.1 Warnings.....	4
1.2 Safety instructions for transporting unit	4
2. Foreword.....	5
2.1 From the manufacturer	5
3. Symbols Use	5
3.1 Signal words	5
4. Responsibilities	6
4.1 Receiving inspection.....	6
4.2 Owner and/or operator responsibilities	6
5. Specifications	6
5.1 AFC-9	6
5.2 CFC-16	6
6. Product Description	7
6.1 Component identification.....	7
6.2 Features.....	7
7. Installation	8
8. Operation	9
8.1 Operation of the container crusher.....	9
8.2 Door handle operation	9
9. Maintenance and Inspection	10
9.1 Inspection	10
9.2 Maintenance instructions	10
9.3 Control valve actuation adjustment.....	10
10. Troubleshooting	11
11. Maintenance Chart.....	12
12. Notes	14

1. Safety Regulations

1.1 Warnings

To avoid serious injury or death, read this manual carefully before operating this unit. Call the manufacturer using the contact information printed on the back cover of this manual if you have any questions. Failure to understand and obey safety instructions may result in unsafe or improper use of this product.

⚠ **The owner / manager must keep this manual for future reference**, and make sure the warning labels on the product are legible and intact at all times. Replacement labels and manuals are available from the manufacturer. Call the manufacturer using the contact information on the back cover of this manual if you have any questions.

⚠ **The unit is required to be anchor bolted to a level concrete floor, for safe operation.** It is recommended to anchor the machine to the floor with four 3/8 or 1/2 in. diameter anchor bolts.

⚠ **This unit is recommended for crushing spin-on oil filters, cartridge oil filters with paper elements, and empty paint cans up to 1 gallon in size.** Do not crush aerosol cans, cylinders of compressed gas, fuel filters, or containers of flammable liquids or solvents. Crushing plastic containers is not recommended.

⚠ **Do not modify this unit or alter the operation in any way to circumvent the interlocking door mechanism.** Modifications to the machine will void all warranties expressed or implied.

⚠ **Do not smoke when operating this unit** and do not operate this unit when someone else in the vicinity is smoking.

⚠ **Wear safety glasses and gloves when operating the unit** and handling the crushed oil filters and paint cans.

⚠ **Never hold the filter by the top** when loading and unloading. Always hold the filter by the sides with the gasket end down.

⚠ **Do not use this unit to perform any operations other than to crush oil filters or empty paint cans.** This unit is for crushing spin-on oil filters, cartridge oil filters with paper elements, and empty paint cans up to 1 gallon in size. Paint from full or partially full cans can solidify and clog the holes in the catch basin.

⚠ **Clean up any spilled oil immediately** so it will not cause a slipping hazard.

⚠ **Do not stack oil filters inside the crushing chamber.**

1.2 Safety instructions for transporting unit

⚠ Failure to understand and obey safety instructions may result in unsafe or improper use of this product. Failure to understand and obey this warning may result in injury and/or property damage.

⚠ The crushing module is very heavy and it is recommended to use a shop crane capable of handling the load or lift truck to perform the lifting. Do not move the unit with the crushing module in the raised position. Always lower the crushing module to its shipping position. The unit is top heavy and can tip over if the crushing module is raised and the unit is not anchored to the floor.

2. Foreword

2.1 From the manufacturer

Thank you for your purchase. To complement the offering of A/C, fluid and nitrogen service equipment, MAHLE Service Solutions has partnered with Gray Manufacturing to provide the highest quality hydraulic and pneumatic equipment available for the professional service technician. This equipment adheres to high standards promised in the MAHLE guarantee including the assurance of innovation and reliability that comes with the Gray Manufacturing name. Please contact MAHLE Service Solutions' customer service at (800) 468-2321 or tech.mss@us.mahle.com with any comments or questions.

3. Symbols Use

3.1 Signal words

Signal words call attention to a safety message or messages, or a property damage message or messages, and designate a degree or level of hazard seriousness. Signal words used in this manual include:

Keyword	Probability of occurrence	Severity of danger if instructions not observed
DANGER	Immediate impending danger	Death or severe injury.
WARNING	Possible impending danger	Death or severe injury
CAUTION	Possible dangerous situation	Minor injury
NOTICE	Possible damage to property	Possible property damage

4. Responsibilities

4.1 Receiving inspection

Before attempting to operate this equipment, thoroughly read and understand this manual. Completely remove all tape and packaging. Inspect the equipment immediately upon delivery. If shipping damage is evident, inform the delivering carrier immediately and contact the manufacturer using the contact information on the back cover of this manual.

4.2 Owner and/or operator responsibilities

The owner of this equipment must read these instructions and maintain them for future reference and for instructing any other users of the equipment. The owner is responsible for keeping all warning labels and instruction manuals legible and intact. Replacement labels and literature are available from the manufacturer. The owner must never authorize or allow anyone to use this equipment until the operator has read and understood the information in this manual and on the accompanying labeling on the equipment itself.

If this equipment is being used in an occupational setting (or workplace), the employer should ensure that all personnel working with and around the equipment know of the risks associated with its use. Personnel involved in the use and operation of this equipment shall be careful, competent, trained, and qualified in the safe operation of the equipment and its proper use when servicing motor vehicles and their components. Safety information provided with this equipment should be emphasized by the employer and understood by each employee. The employer must make this manual available to all personnel using this equipment and all personnel must read and understand the contents of this manual. If the operator is not fluent in English, the manufacturer's instructions and warnings shall be read to and discussed with the operator in the operator's native language by the employer, making sure that the operator comprehends its contents and observes the proper procedures for use of this equipment.

5. Specifications

5.1 AFC-9

Model AFC-9	US units	Metric units
Height	77.125 in	195.9 cm
Width	20.5 in	52.1 cm
Depth	16.75 in	42.6 cm
Weight	242 lb	109.8 kg
Height (Crushing chamber)	9 in	22.9 cm
Width (Crushing chamber)	8 in	20.3 cm
Depth (Crushing chamber)	8 in	20.3 cm
Air Inlet	¼ female NPT	¼ female NPT
Air Pressure	100-200 PSI	6.9-13.8 Bar
Catch Basin Connection	¾ female NPT	¾ female NPT

5.2 CFC-16

Model CFC-16	US units	Metric units
Height	85.5 in	217.2 cm
Width	20.5 in	52.1 cm
Depth	16.75 in	42.6 cm
Weight	282 lb	127.9 kg
Height (Crushing chamber)	16.25 in	41.3 cm
Width (Crushing chamber)	10 in	25.4 cm
Depth (Crushing chamber)	8 in	20.3 cm
Air Inlet	¼ female NPT	¼ female NPT
Air Pressure	100-200 PSI	6.9-13.8 Bar
Catch Basin Connection	¾ female NPT	¾ female NPT

6. Product Description

6.1 Component identification

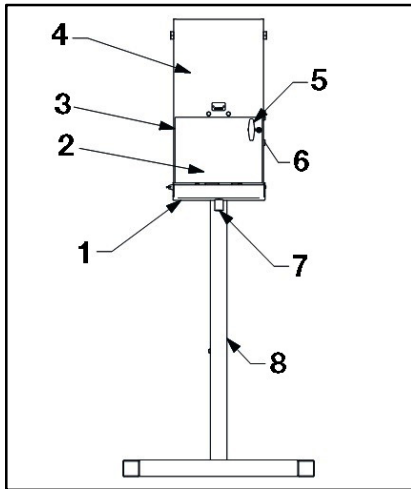

Fig. 1: Front view

- 1 Catch basin
- 2 Crushing chamber
- 3 Door
- 4 Ram & ram cylinder
- 5 Door handle
- 6 Control valve & air inlet
- 7 Catch basin outlet
- 8 Stand

6.2 Features

Pneumatic Powered Ram: Pneumatic power gives you the advantages of long life, low maintenance, and quick crushing action. Also no electrical connections are required eliminating the electrical hazard and the problems of dirty and/or faulty connections.

Interlocking Door: The door interlock restrains the door from opening until the ram is fully raised.

Convenient Operation: One hand is required to close the door and latch it. After the door is latched, the crushing chamber is completely enclosed to prevent injuries and to prevent oil splatter.

Versatile Installation: The stand is standard with the unit, not optional as with many competitors' equipment. When crushing oil filters, the catch basin can be connected to the bottom or either side to a variety of waste oil containers. The unit can be placed over a workbench by placing the stand post behind the workbench.

Large Crushing Chamber: Automotive spin-on filters and up to 1-gallon paint cans will fit in the crushing chamber.

7. Installation

1. Locate a suitable place to install the unit. This unit must be installed indoors on a level surface. The unit is required to be anchor bolted to a concrete floor, for safe operation.
2. Position the crusher in the desired location in your shop. Mark the floor for the anchor bolt location to match the holes in the base of the stand. Four 3/8 or 1/2 inch diameter anchor bolts are recommended to install the unit. Install the anchor bolts according to the manufacturer's instructions. Secure the unit to the floor with the anchor bolts.
3. The unit is shipped with the crushing module fastened to the stand in a lowered position.
- ⚠ CAUTION!** The crushing module is very heavy and it is recommended to use a shop crane capable of handling the load or a lift truck to perform the lifting. Unbolt the crushing module from the post. Note: the number of bolts will depend on the model. Do not remove the 5/16 inch screw from the top of the post, if equipped. Raise the crushing module from the shipping position to the working position. Align the mounting holes on the crushing module with the holes in the stand post and insert the bolts provided. Secure with the nuts on the bolts.
4. Connect the catch basin to the appropriate waste oil container as required by national, state, or local regulations. The catch basin connection is a 3/4 female NPT fitting located on the bottom or on the side. If the opposite side connection is desired, simply remove the catch basin and install with the connection on the desired side. The unit may be connected using a 3/4 male NPT fitting and pipe to a remote waste oil tank. Another option is to connect the catch basin to a drum. Use a 3/4 pipe close nipple, a 1 in. I.D. oil resistant hose and a hose clamp to connect the hose to the catch basin. Install the hose in the bung of the drum and cut the length of the hose so it will fit in the drum 2 to 4 in. The installation must provide for the easy removal of the catch basin as sludge and semi-solid residue from oil filters may accumulate. The catch basin requires periodic cleaning to remove solid residues. All such residues must be transferred to an acceptable container.
5. If the unit is to be used solely for crushing empty paint cans, the catch basin does not need to be connected to any container. However, a drip pan should be placed beneath it or the pipe drain fittings should be plugged. The installation of the unit should provide for easy removal of the catch basin to remove inadvertent spills and foreign material, which may accumulate in the catch basin.
6. Connect the air supply to the air inlet. The inlet connection is 1/4 female NPT. The unit is now ready for use. Recommended operating air pressure is 100 psi minimum for most paint cans and car and light truck filters, 120-PSI minimum for heavy truck filters. Maximum recommended air pressure is 200 psi.
7. If for any reason the unit does not operate properly after reviewing the steps above consult the Troubleshooting section in this Owner's Manual or contact the manufacturer using the contact information printed on the back cover of this manual for further instructions and assistance. Please have the model number and serial number of your crushing equipment available. The serial number is permanently stamped on a metal tag located above the door.

8. Operation

8.1 Operation of the container crusher

1. Place empty paint can with the lid removed or oil filter with the open end down in the center of the crushing chamber.
 2. Close door and turn door handle clockwise approximately 180 degrees. You may walk away to perform other tasks. Upon returning, the filter or paint can will be crushed. If you want to crush containers in succession, listen for air to stop flowing (up to 45 seconds). Some noise and vibration usually accompany the crushing process.
 3. To remove the crushed paint can or filter, turn the door handle counterclockwise and air will exhaust from the ram cylinder. The door will not open until the ram is fully raised (approximately 10 seconds). Open the door and remove the crushed, empty paint can or oil filter.
 4. Note: A filter may be crushed for extended periods of time. The unit can be left under pressure until the next filter or can is ready for crushing. The catch basin outlet can become clogged with sludge and semisolid waste from filters. It is necessary to remove the catch basin and clean it periodically. Deposit solid residue in acceptable containers. The oil level in the catch basin can be viewed through the opening beneath the door when the door is closed. You may crush several filters at one time if they are all of similar height and you have adequate air pressure.
- ⚠ **CAUTION:** Crushing multiple filters of different heights or materials can damage the crushing module. Always have the filters arranged so that they do not cause the ram to load unevenly.

8.2 Door handle operation

Door closed and handle full clockwise, door is latched and ram extends (Fig. 2).

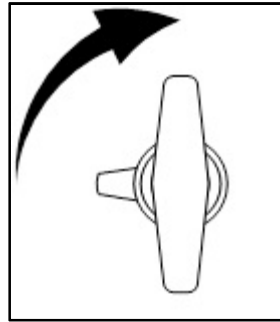

Fig. 2: Turn handle full clockwise to crush cans

Door closed and handle turned 90 degrees counterclockwise, air exhausts, ram retracts and door remains closed (Fig. 3).

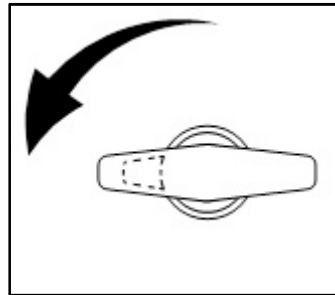

Fig. 3: Turn handle 90 deg. counterclockwise to retract ram

Handle turned fully counter-clockwise, air exhausts and ram retracts, door will open when ram is fully retracted (Fig. 4).

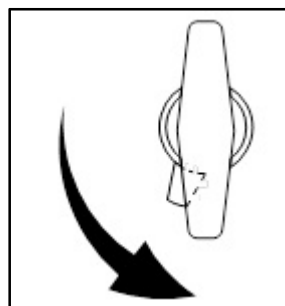

Fig. 4: Turn fully counterclockwise to retract ram and open door

9. Maintenance and Inspection

⚠ **WARNING** - The equipment must be inspected according to the requirements of this section. Failure to properly inspect the equipment could lead to severe injury or death. The equipment must be removed from service and inspected immediately if it is subjected to an abnormal load or a shock load. If any irregularities or problems are detected during an inspection, the equipment must be removed from service immediately and repaired. Contact the manufacturer at the numbers and address printed on the back cover of this manual.

9.1 Inspection

The owner must inspect, or appoint a knowledgeable person to inspect the unit for signs of corrosion and / or excessive wear. Visual inspection should be made before each use of the unit, checking for abnormal conditions. Regular inspections should be made weekly for daily use and monthly for intermittent use. Each unit must be inspected immediately if subjected to an abnormal load or shock. Any unit which appears to be damaged in any way, is found to be badly worn, or operates abnormally shall be removed from service until necessary repairs are made.

- Inspect the door for closure and door handle latching operation. The door should close easily and the door handle should loosely latch with a 90-degree rotation of the door handle. Further 90-degree rotation of the handle should clamp the door shut and actuate the control valve. There should be the sound of air flowing for up to 45 seconds until the ram is fully lowered and the air pressure in the ram cylinder equalizes with the air supply.
- After the air stops flowing, check the unit for excessive leaks. An excessive leak is a leak which can be heard and which degrades the performance of the unit. Minor leaks do not adversely affect the operation of the unit.
- Unlatch the door and the air should exhaust from the ram cylinder. The door should not open until the ram has returned to its fully raised position (approximately 10 seconds).
- Inspect crushing chamber for damage or worn parts.
- If any irregularities or problems are detected during an inspection, the unit must be removed from service immediately and repaired. Contact the manufacturer using the contact information on the back cover of this manual.

9.2 Maintenance instructions

⚠ **WARNING** - All inspection and maintenance procedures must be performed after the equipment has been removed from service. Failure to do this may result in personal injury and/or property damage.

- All warning and capacity labels should be readable and complete. Wash external surfaces of jack, labels, and decals with a mild soap solution.
- Lubricate all rotating and sliding portions of the jack monthly.

9.3 Control valve actuation adjustment

❗ **Note:** The setscrew on the door that actuates the control valve and the pawl on the door handle latch are adjusted at the factory and should never need adjustment.

1. Make sure the two screws securing the control valve on the right hand side of the unit are tight. Make sure the two screws securing the handle latch to the door are tight and the two jam nuts securing the latch pawl to the stem are tight.
2. Loosen the jam nut securing the set screw on the door and back the setscrew out. Close door and turn door handle fully clockwise to solidly latch the door.
3. Using a hex wrench, slowly tighten the setscrew until the top platen lowers and there is no air leakage detected around the spool of the control valve. Tighten the setscrew 1/2 turn further and secure the setscrew with the jam nut.
4. Rotate the latch handle 1/4 turn counterclockwise. The air should exhaust and the ram should retract, but the pawl should remain loosely engaged with the door closed.
5. Rotate the latch fully counterclockwise and the door should open. Repeat steps 2 through 5 if the door does not operate correctly.

10. Troubleshooting

This section is a list of potential problems and solutions. If the solution listed fails to correct the problem, call the manufacturer at the numbers and address printed on the back cover of this manual. Please have the model number, and serial number of your jack available. The serial number is permanently stamped on a metal tag located above the door or on the shroud at the top.

Problem	Cause/Solution
Ram does not actuate	<ul style="list-style-type: none"> • Not connected to air supply. Connect unit to adequate air supply (see Installation instructions section of manual). • Setscrew on door is not properly actuating the control valve. Adjust setscrew (see Control Valve Actuation Adjustment section).
Inadequate crushing action	<ul style="list-style-type: none"> • Air pressure too low. 100 psi will adequately crush most car and light truck filters. Heavy truck filters require a minimum of 120 psi. • Some brands or models of oil filters are stronger than other brands and therefore will not crush as flat. • Excess air leakage. Locate source of leak(s) and repair. • Crushing too many filters at one time or there is too big of height difference in the filters you are crushing at one time. Crush filters individually.
Oil is running over the catch basin	<ul style="list-style-type: none"> • Make sure vehicle is in neutral and parking brake is disengaged. Always chock wheels on opposite end prior to lifting.

12. Notes

MAHLE

MAHLE Aftermarket Inc.

10 Innovation Drive
York, PA 17402 U.S.A.

Phone: (800) 468-2321

Fax: (717) 755-8304

E-mail: tech.mss@us.mahle.com

www.servicesolutions.mahle.com

670-90747