

# **OPERATION MANUAL**

## **RTI**

### **BRC35 ON-THE CAR BRAKE ROTOR LATHE**

**RTI TECHNOLOGIES, INC.**

4075 East Market Street  
York, PA 17402

Manual P/N 035-80253-00

# **BRAKE LATHE**

## **BRC 35**

**CONGRATULATIONS...** You have purchased one of the finest lathes for on-the-car machining of brake rotors available at any price.

### **GREAT RESULTS WITH THE BRC 35 ARE AHEAD...**

- ✎ Fast to set up and simple to operate.
- ✎ Professional, high quality on-the-car brake rotor turning with "total alignment" every time.
- ✎ Uses two reference points - hub axis and caliper mount geometry. Brake pads will now be perfectly aligned with the rotor.
- ✎ Components have maximum flexibility of assembly to allow customization for individual preferences during setup.
- ✎ Integral, high strength storage container keeps accessory items in one convenient location; no more hunting for tools.
- ✎ Mobile stand features a broad range of adjustment; turn rotors while the car sits on floor jacks or on a hydraulic lift.

# CONTENTS

Warranty .....	Page 3
Lathe & Accessories .....	Page 4
Drive Stand & Motor .....	Page 6
Main Features .....	Page 8
Mounting the Lathe .....	Page 10
Attaching the Drive Motor .....	Page 12
Control Devices .....	Page 13
Turning a Rotor .....	Page 14
Slideway Adjustment .....	Page 17
Summary .....	Page 18

## WARNING

The Wheel Connection Shaft is connected to the Motor Shaft with a Universal Coupling.

**The Collar provided on the Connecting Shaft must be slid over the Universal Coupling when not in use.**

Serious injury may result if power is applied to the Motor while the Wheel Connection Shaft is hanging loose.

# WARRANTY

*Fill out and return the Warranty Card within 90 days to activate warranty and free lifetime technical support.*

**WARRANTY...** The BRC 35 is warranted to be free of defects in workmanship and materials for a period of one year from date of purchase by original purchaser.

If the product fails within this period, it will be repaired or replaced at the manufacturer's option, provided (1) factory authorization has been issued and (2) the product is submitted with proof of purchase.

Liability under this warranty is expressly limited to repairing or replacing the product or parts thereof.

This warranty does not apply to product or parts broken due to accident, overload, abuse, tampering, or alteration.

If this warranty does not apply, the retail purchaser shall pay all costs for labor, material, and transportation.

**FOR SERVICE OR TECHNICAL ASSISTANCE**

**800-468-2321 (Extension 259)**

**FAX 717-755-8304**

# LATHE & ACCESSORIES

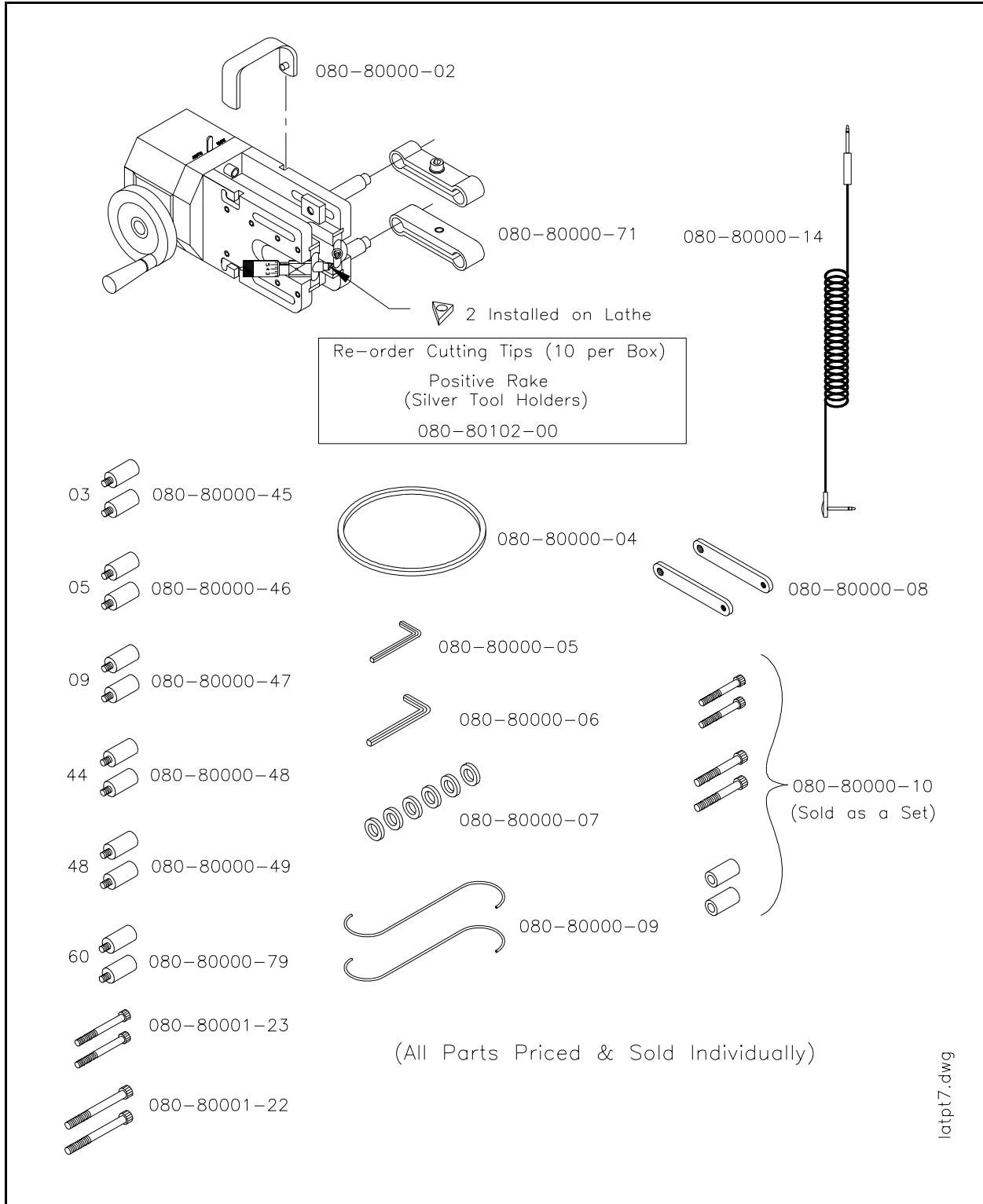
## BRC 35

RTI Part No.	Description	Qty
080-80000-71	Bracket Twin Cylinder (80mm)	2
080-80000-04	Band Silencer	1
080-80000-05	Wrench Hex Key (6mm)	1
080-80000-06	Wrench Hex Key (8mm)	1
080-80000-07	Spacer Mounting	6
080-80000-08	Bar Threaded	2
080-80000-09	Hook "S" Shaped	2
080-80000-10	Adapter Hollow (48mm lg.)	2
	Bolt 8mm x 1.25 (70mm lg.)	2
	Bolt 10mm x 1.50 (70mm lg.)	2
080-80001-22	Bolt 10mm x 1.50 (90mm lg.)	2
080-80001-23	Bolt 10mm x 1.50 (80mm lg.)	2
080-80000-45	Threaded Adapter 03 (M10 x 1.25)	2
080-80000-46	Threaded Adapter 05 (M10 x 1.50)	2
080-80000-47	Threaded Adapter 09 (M12 x 1.50)	2
080-80000-48	Threaded Adapter 44 (M11 x 1.50)	2
080-80000-49	Threaded Adapter 48 (M9 x 1.25)	2
080-80000-79	Threaded Adapter 60 (M14 x 2.00)	2
080-80000-14	Cord 12 Volt Coiled	1
080-80000-02	Handle Lathe Carrying	1

**Refer to next page for illustration of above components.**

# LATHE & ACCESSORIES

## BRC 35



# DRIVE STAND & MOTOR

## BRC 35

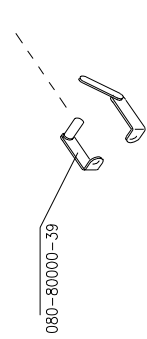
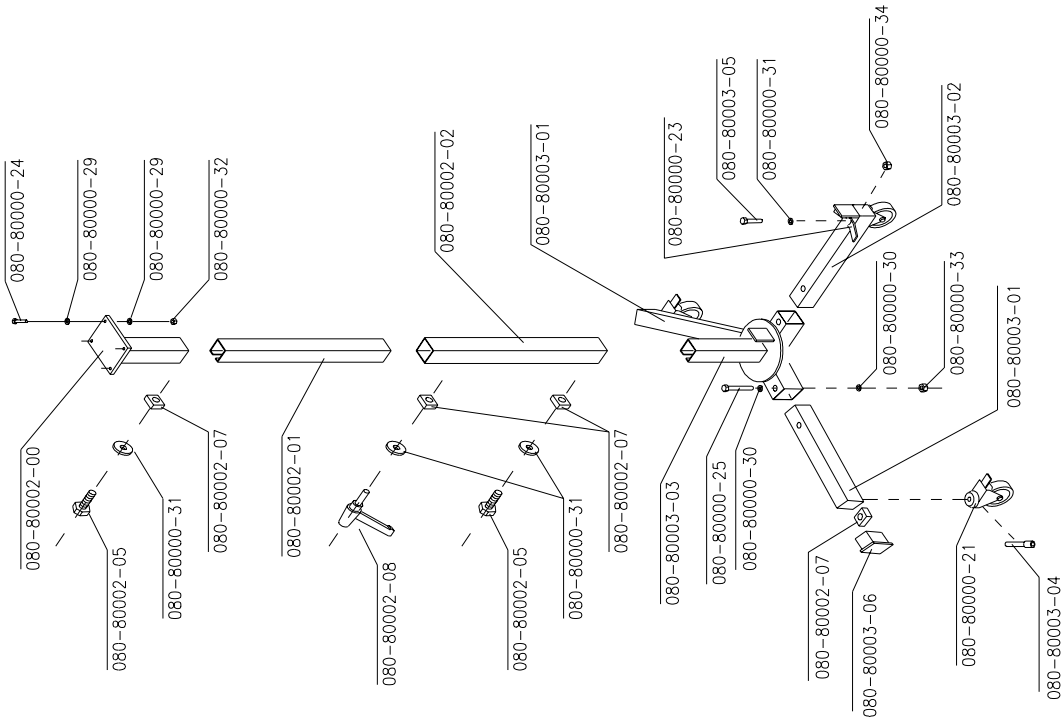
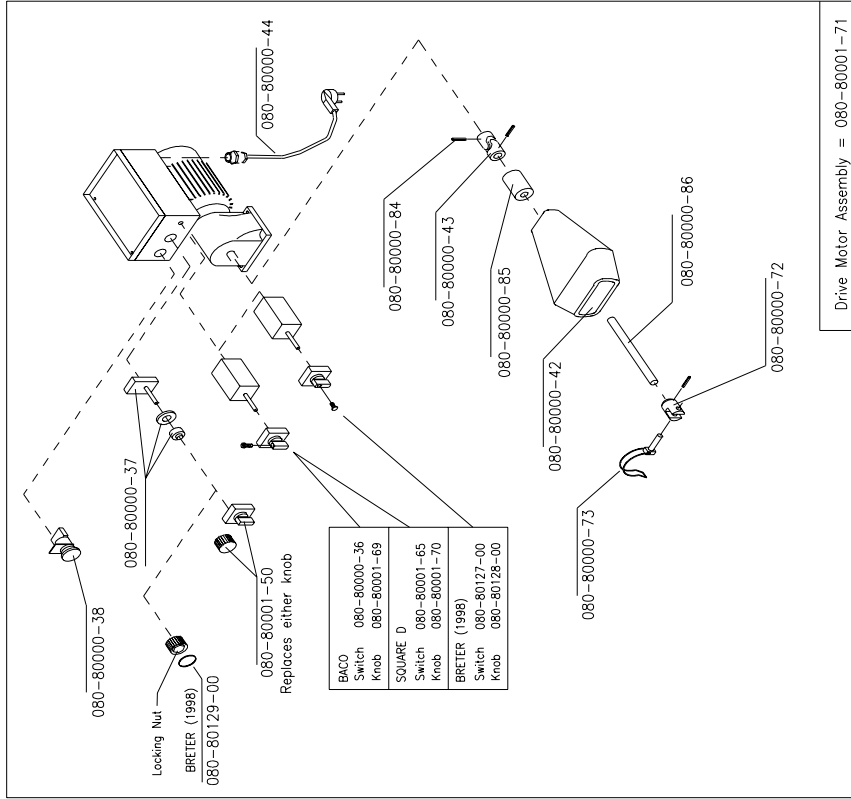
RTI Part No.	Description	Qty
080-80000-83	Motor Gear Drive (Complete Assembly) Voltage: 110 or 220 VAC 110 volt unit has been tested and approved for 100 volt operation in Japan	1
080-80002-00	Motor Mount	1
080-80002-01	Inner Column	1
080-80002-02	Outer Column	1
080-80003-03	Base	1
080-80003-01	Short Leg	2
080-80003-02	Long Leg	1
080-80000-21	Swivel Caster	3
080-80002-08	Locking Handle	1
080-80000-23	Accessory Box Support	1
080-80000-24	Bolt M6 x 1mm x 35mm Lg.	4
080-80000-25	Bolt M8 x 1.25mm x 60mm Lg.	3
080-80002-05	Bolt	2
080-80003-05	Bolt	1
080-80003-04	Bolt Allen Socket Head M10 x 1.50mm x 25mm Lg.	3
080-80003-06	Plastic Cap	3
080-80000-29	Washer M6	8
080-80000-30	Washer M8	6
080-80000-31	Washer M10	3
080-80000-32	Nut M6 x 1.00mm	4
080-80000-33	Nut M8 x 1.25mm	3
080-80002-07	Nut Square	6

**Refer to next page for illustration of above components.**

# DRIVE STAND & MOTOR

## BRC 35

Fan Blade 080-80001-56  
 End Cover 080-80001-57  
 Mtg. Screws 080-80001-62

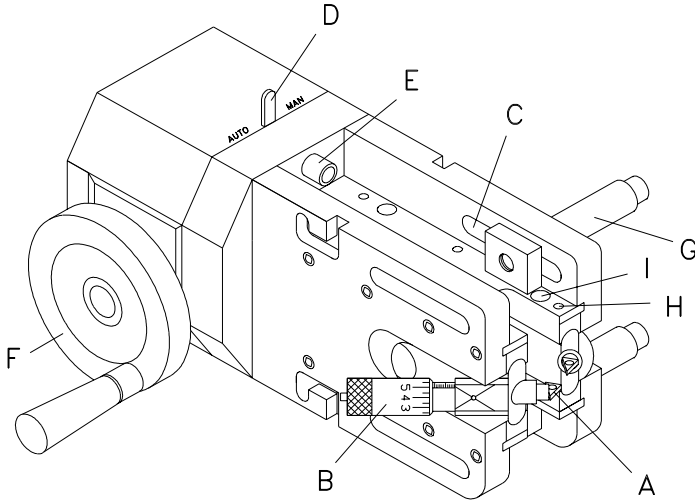


(All Parts Priced & Sold Individually)

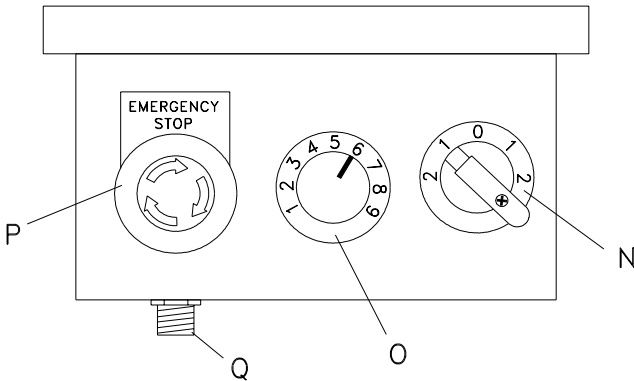
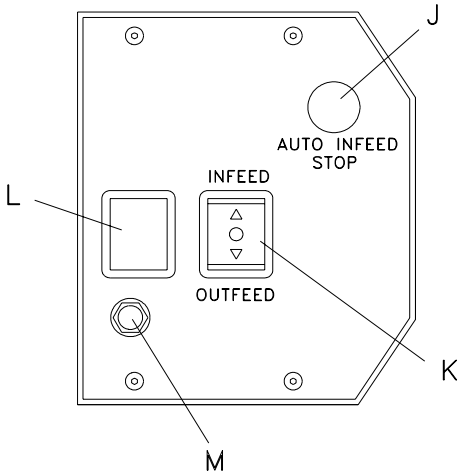


# MAIN FEATURES

## BRC 35



- A- Cutting Tips
- B- Cut Depth Micrometer Adjustment
- C- Mounting Slots
- D- Auto/Manual Shift Lever
- E- Lock for Auto/Manual Shift Lever
- F- Manual Feed Handwheel
- G- Mounting Adaptors
- H- Slideway Adjustment Screws (8)
- I- Slideway Adjustment Screw (4)
- J- Adjustable Infeed Stop
- K- Infeed/Outfeed Selector Switch
- L- Power Indicator Light
- M- Socket for 12 volt Cable
- N- On/Off, 2 Speed Bi-directional Switch
- O- Feed Rate Adjustment
- P- Emergency Stop
- Q- Socket for 12 volt Cable



LATPT33.DWG

## CAUTION

Check for any end-play in the wheel bearing before mounting the BRC 35 Brake Lathe.

A loose wheel bearing may cause a poor surface finish.

If bearing play is adjustable, tighten nuts slightly before machining, and then re-adjust to factory specifications afterward.

If there is play in a non-adjustable bearing, it should be replaced before machining the rotor.

Most non-adjustable bearings are double-row ball bearings that require pre-load. Tapered roller bearings found on the front of most rear wheel drive vehicles are designed to operate with end-play.

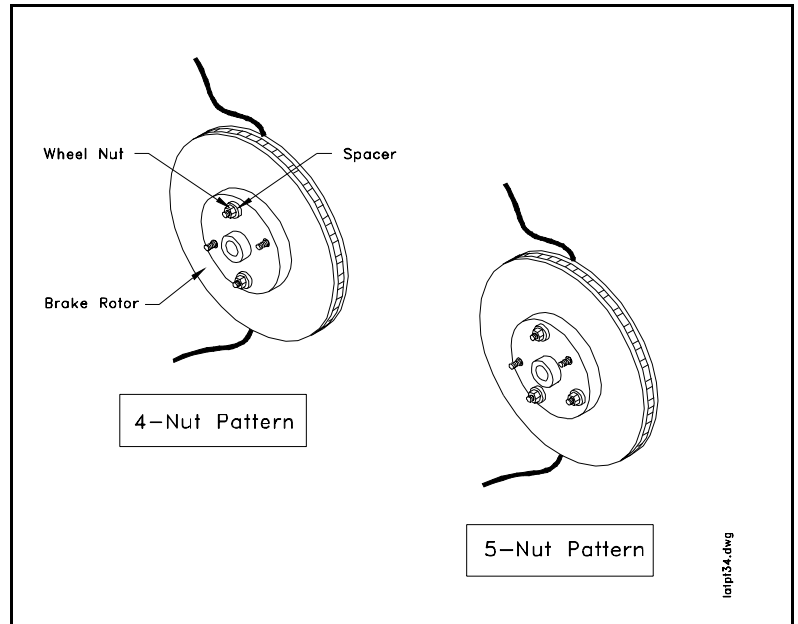
# MOUNTING THE LATHE

1. Place automobile in NEUTRAL with parking brake OFF and raise on lift. Start on passenger side and remove wheel nuts and wheel.
2. Place Spacers on wheel studs as shown in Figure 1. Replace and tighten nuts to manufacturer's specification using torque wrench.
3. Remove the brake caliper and hang it out of the way using an S-Hook.
4. Remove all rust and dirt from the brake caliper bolt area. Failure to clean these surfaces will result in unsatisfactory machining.
5. Select Threaded Adapters with threads matching brake caliper mounting bolts.

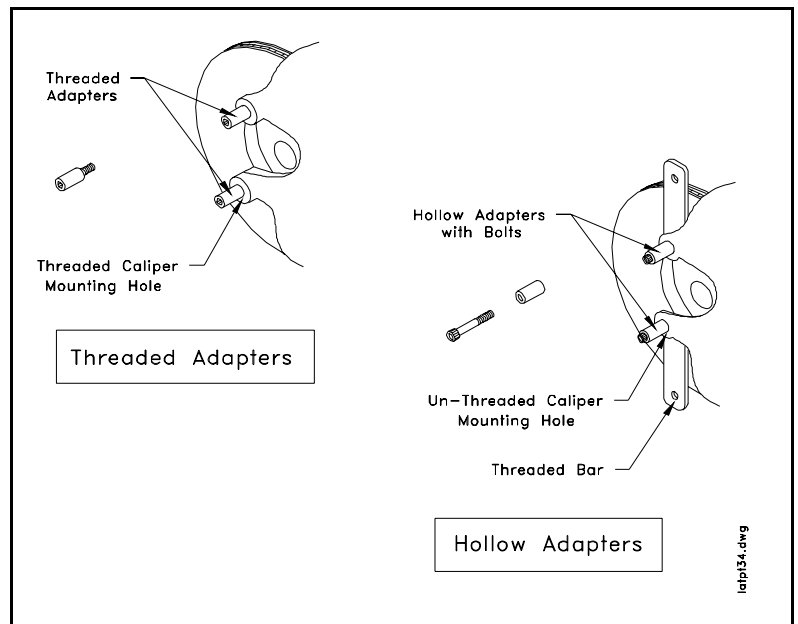
Insert and tighten Threaded Adapters in the brake caliper bolt mounting holes.

Some caliper mounting holes are not threaded. In these cases, use Hollow Adapters, Threaded Bars, and Bolts. Refer to Figure 2.

Some caliper mountings may require special adapters included in the Deluxe Adapter Kit.



**Figure 1** Mounting of Spacers & Wheel Nuts



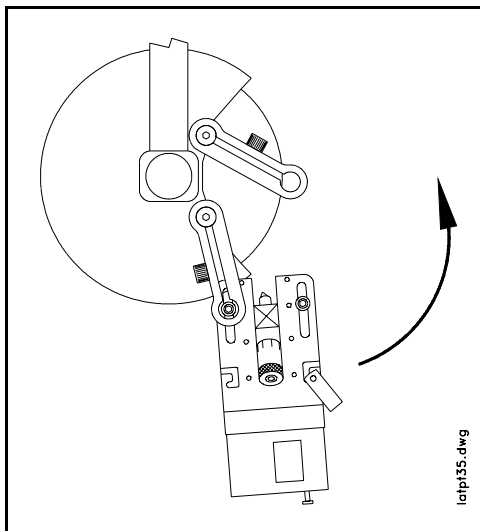
**Figure 2** Mounting of Threaded or Hollow Adapters

# MOUNTING THE LATHE

- Place Twin Cylinder Mounting Brackets on each of the Adapters mounted in the preceding step.

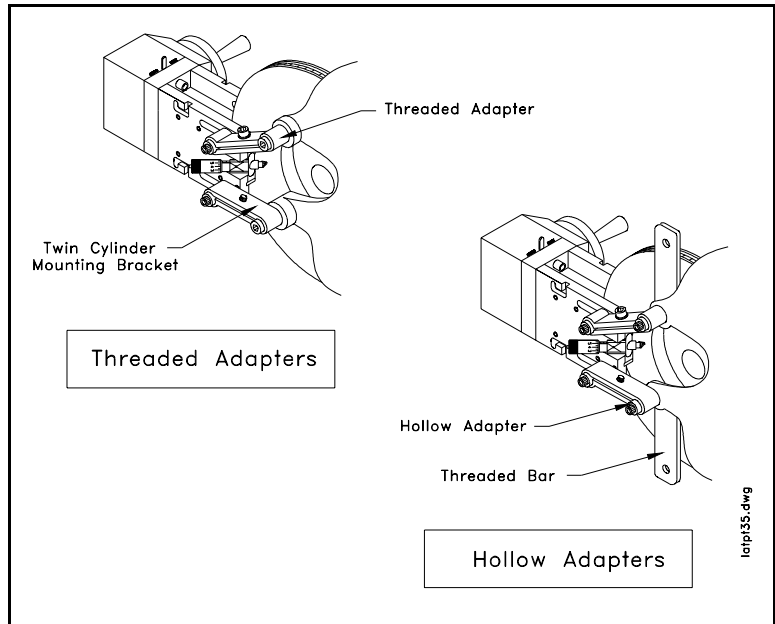
Do not tighten the Allen Socket Bolts in the Mounting Brackets.

- Hang the Lathe on the lower Twin Cylinder Mounting Bracket as shown in Figure 3.

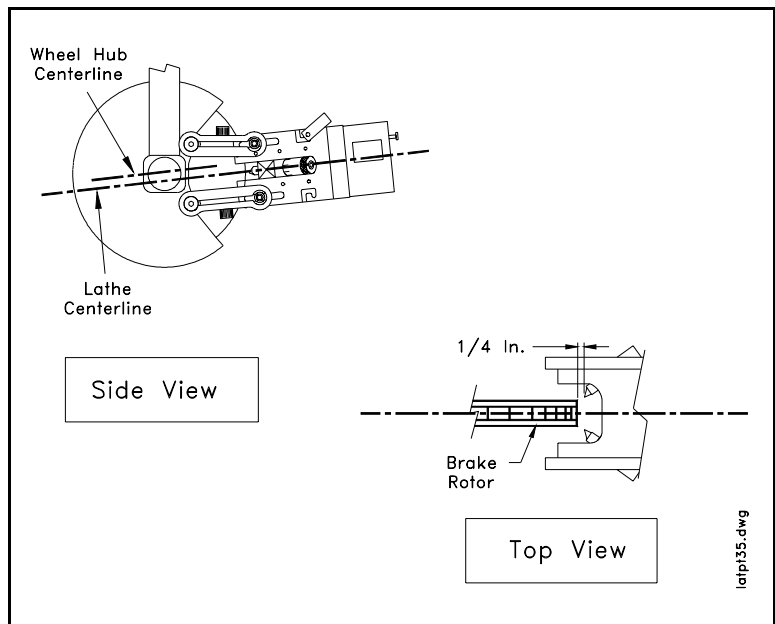


**FIGURE 3 HANG THE LATHE**

- Swing the Lathe upwards and insert the top Twin Cylinder Mounting Bracket onto the Lathe mounting bracket. See Figure 4.
- Position the Lathe so that the Lathe centerline is slightly below the center of the wheel hub and the brake rotor is centered between the side plates of the Lathe. Refer to Figure 5.
- Tighten Allen Socket Bolts in both Twin Cylinder Mounting Brackets.



**Figure 4 Mounting the Lathe**



**Figure 5 Positioning the Lathe**

# ATTACHING THE DRIVE MOTOR

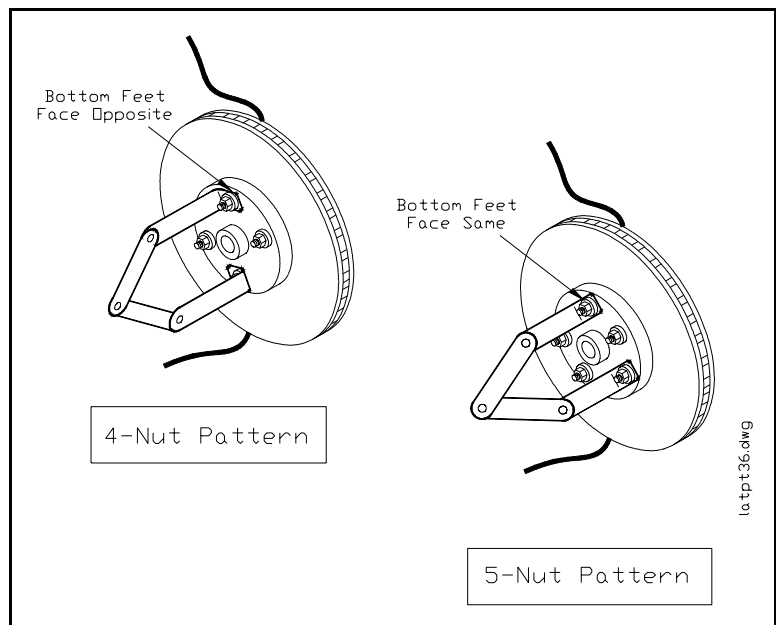
1. Attach the Wheel Drive Brackets, with Spacers, to the two vacant wheel studs as shown in Figure 6. Leave the wheel nuts slightly loose.
2. Slide the sleeve on the connecting shaft of the Drive Motor away from the universal coupling so the shaft is free to articulate.
3. Position the Drive Motor Stand and connect the Wheel Drive Brackets to the end of the Drive Motor Shaft.
4. Tighten the wheel nuts so the Wheel Drive Brackets are on the centerline of the wheel hub.
5. Carefully adjust the Drive Motor Stand so the shaft aligns with the axis of rotation of the wheel.

Refer to Figure 7 for proper setup and alignment.

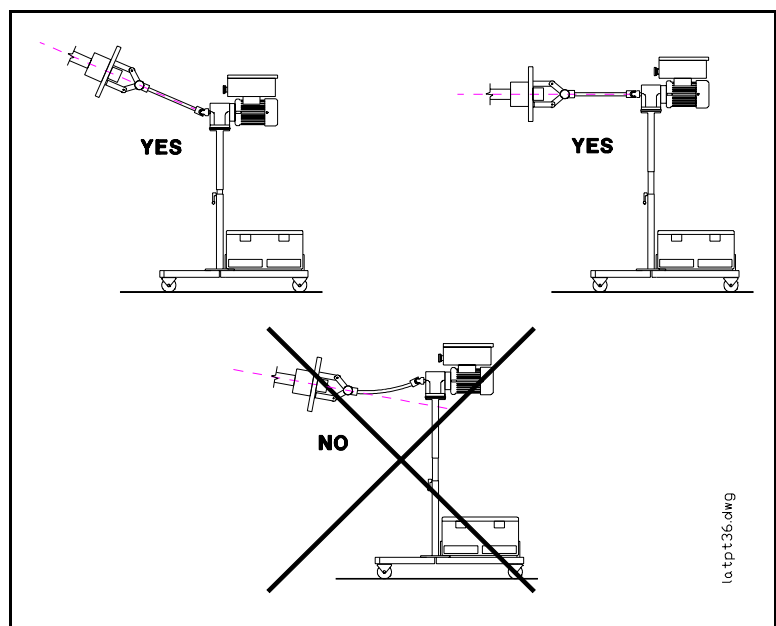
6. Set the locks on the Drive Motor Stand casters. Check that adjusting handles on the stand are tight.
7. Slide the vinyl cover over the Wheel Drive Brackets.

**This cover must remain in place during operation of the Wheel Drive Motor.**

8. Connect the coiled Power Cable between the Wheel Drive Motor and the Lathe.



**Figure 6** Mounting the Wheel Drive Brackets



**Figure 7** Aligning the Wheel Drive Motor

# CONTROL DEVICES

## FEED DIRECTION SWITCH

Direction of travel of the cutting tools is controlled by a 3-position switch on the Lathe Control Panel. Pressing the top activates INFEED (towards the center of the rotor) and pressing the bottom activates OUTFEED (away from the center of the rotor). Between these positions is the OFF position.

## INFEED STOP

This switch stops travel of the cutting tools when moving towards the center of the rotor during automatic operation.

## POWER ON LIGHT

This light will be on when the lathe is feeding in or out (Feed Direction Switch pressed for INFEED or OUTFEED). The brightness will vary depending on the setting of the Feed Rate Switch (1 is dim, 9 is brightest).

The light will be OFF if the Infeed Stop is pushed in all the way.

## EMERGENCY STOP

The Emergency Stop Button stops the Drive Motor and Lathe. Turn and pull (See arrows on knob) to reset. Some switches do not require turning.

## FEED RATE SWITCH

Rate of travel (feed) of the cutting tools is controlled by the variable Feed Rate Switch on the Drive Motor Control Panel (1 is slow, 9 is fast).

## DRIVE MOTOR SWITCH

The Drive Motor turns the rotor clockwise or counter-clockwise in one of two speeds (1 is slow, 2 is fast). This 5-position switch is located on the Drive Motor Control Panel. The middle position is OFF.

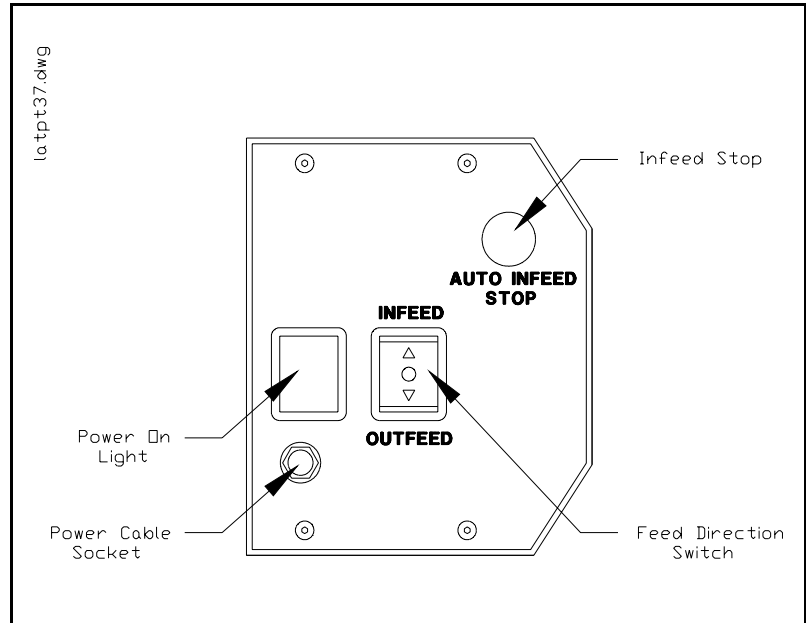


Figure 8 Lathe Controls

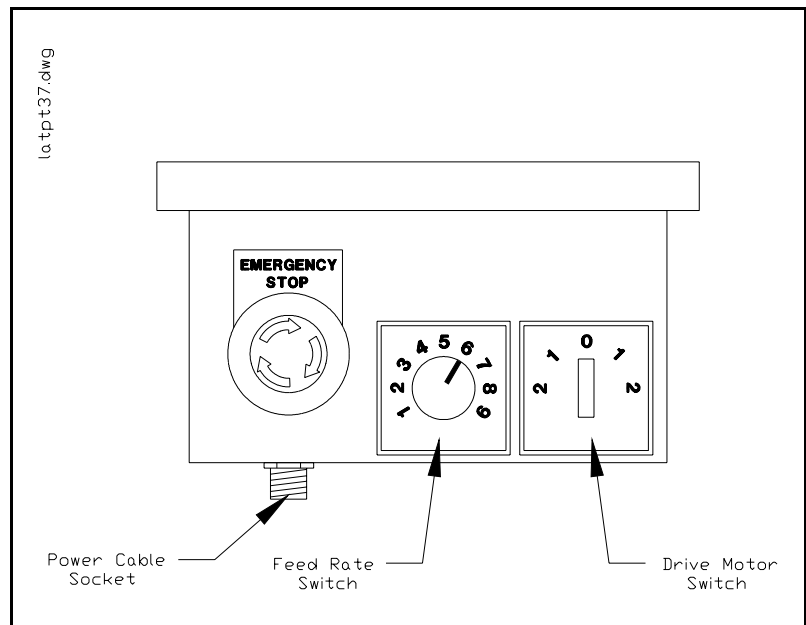


Figure 9 Drive Motor Controls

# TURNING A ROTOR

- 1) Mount the Lathe and attach the Drive Motor per the instructions in the preceding section.

The Silencer Band can be mounted around the outer edge of the rotor to reduce noise during machining if desired. This must be done before mounting the Lathe.

- 2) Set the Feed Direction Switch on the Lathe Control to OFF (middle position).
- 3) Set the Drive Motor Switch on the Drive Motor Control to OFF (Marked "0").

- 4) Check that the coiled Power Cable is connected between the Drive Motor and the Lathe.

- 5) Check that the Emergency Stop Button is reset to ON (if not, turn and release to reset).

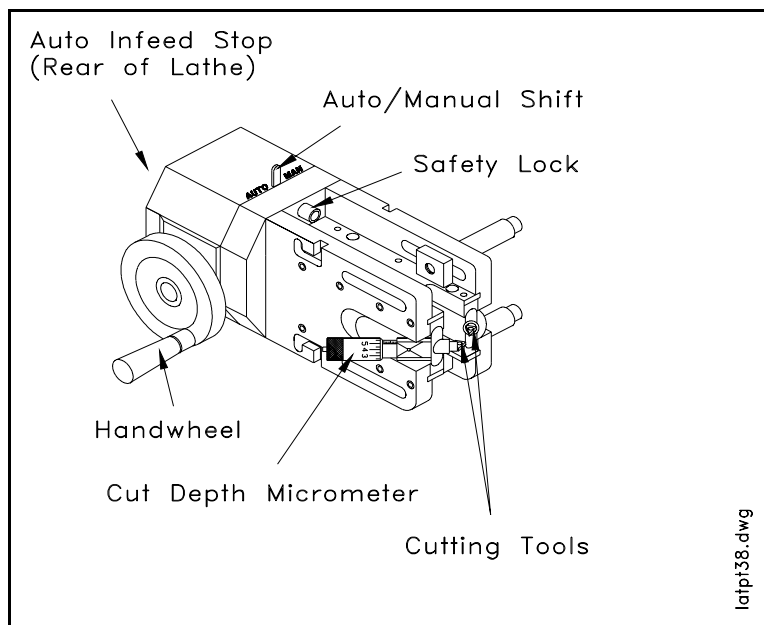
- 6) Plug the power cord on the Drive Motor into a 120 vac supply.

- 7) Turn the Drive Motor Switch clockwise to number 1. The rotor should be turning in the direction shown in Figure 11.

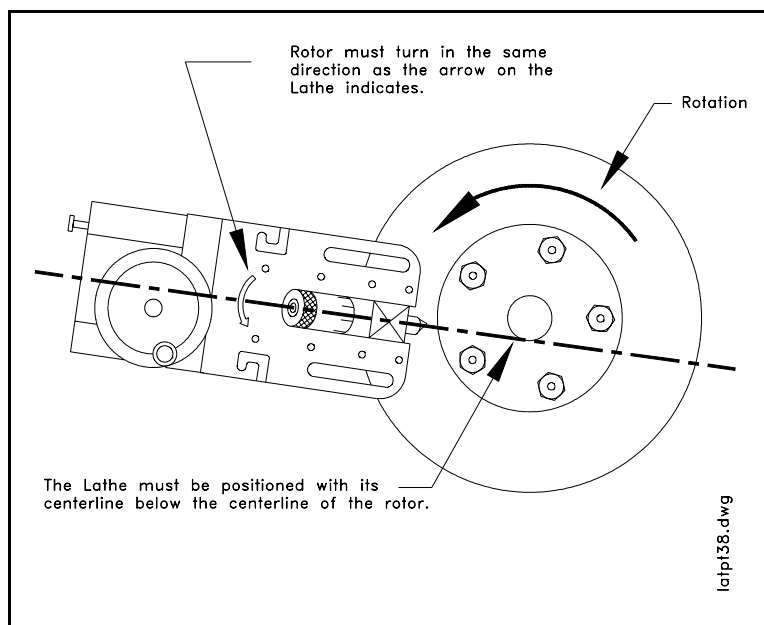
If not, turn the Drive Motor Switch counter-clockwise to number 1.

- 8) Press the Safety Lock and move the AUTO/MAN Shift to MANUAL.

- 9) Using the Hand Wheel, move the cutting tool tips to about ½ in. inward from the outer edge of the Rotor.



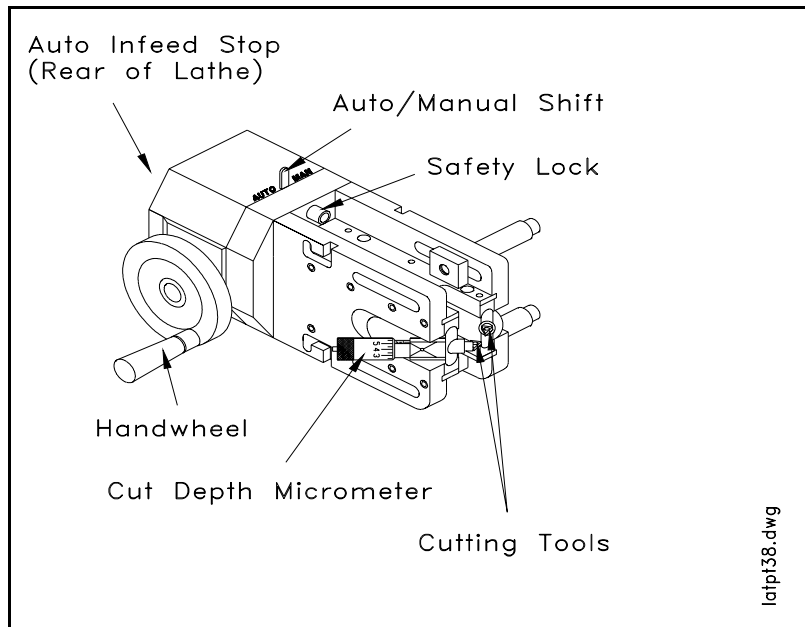
**Figure 10** Lathe Controls



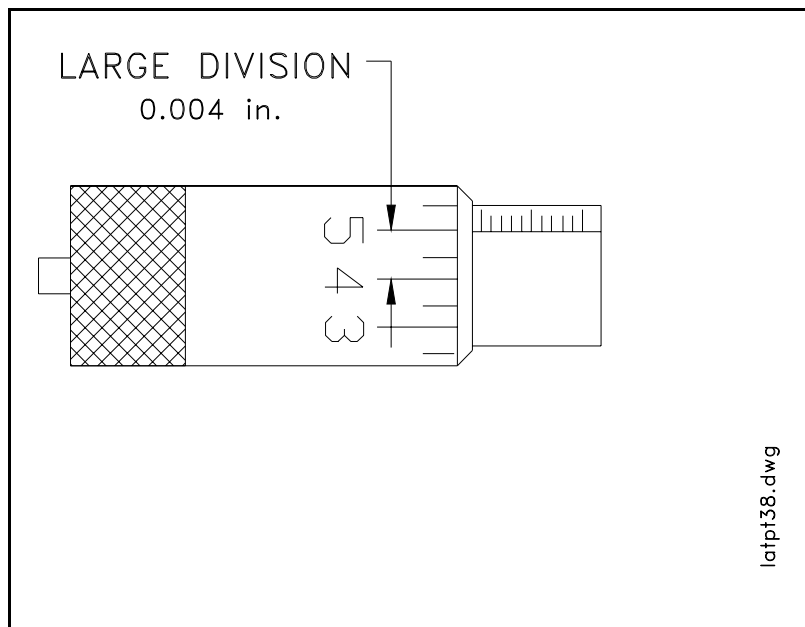
**Figure 11** Direction of Rotor Rotation

# TURNING A ROTOR

- 10) Use the Cut Depth Micrometer to move both cutting tool tips towards the rotor until they *just touch* the rotor surface.
- 11) Turn the hand wheel to manually feed the cutting tools outward toward the edge of the rotor to remove any rust build-up on the outer edge.
- 12) Manually feed the cutting tools inward towards the center of the rotor to a point slightly beyond the contact surface of the brake pads. Use care as the depth of cut may vary due to runout in the surface of the rotor.
- 13) Push the Auto Infeed Stop button all the way in. Twisting the knob while pushing inward makes this step easier. This sets the point where the cutting tools will stop during automatic feed towards the center of the rotor in the following steps.
- 14) Press the Safety Lock and move the AUTO/MAN Shift to AUTO.
- 15) Turn both Cut Depth Micro-meters clockwise one large division to move the cutting tool tips into the faces of the rotor by 0.004 in. Figure 13 illustrates that 0.004 in. is the distance between two numbers on the micrometer.
- 16) Turn the Feed Rate Switch on the Drive Motor Control to 9 (fast feed).
- 17) Press the top (OUTFEED) of the Feed Direction Switch on the lathe. The lathe cutting tools will automatically feed outward, making a rough cut on the rotor.



**Figure 12** Lathe Controls



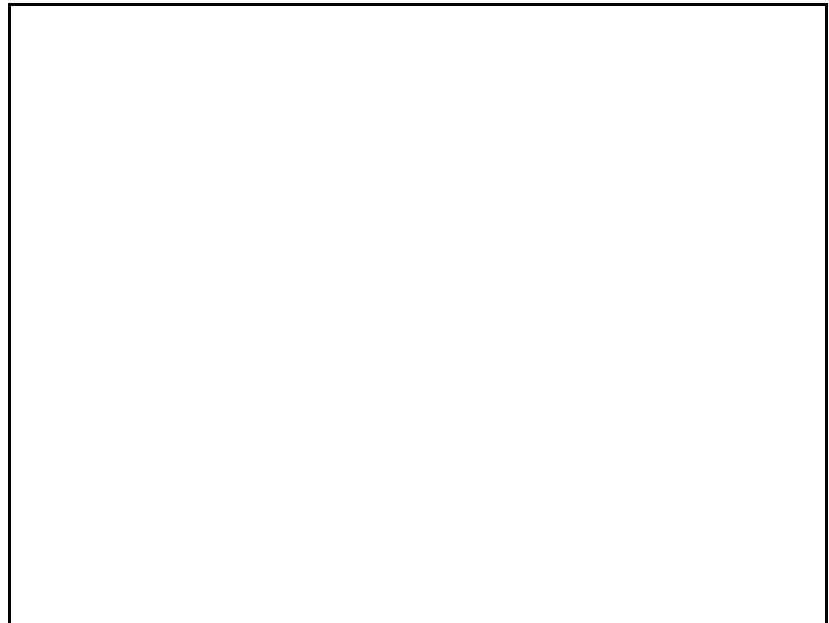
**Figure 13** Cut Depth Micrometer



# TURNING A ROTOR

- 18) When the cutting tools have moved outward beyond the edge of the rotor, press the bottom (OUTFEED) of the Feed Direction Switch on the lathe to place the switch in the OFF position.
- 19) Momentarily turn off the Drive Motor and check the surface of the rotor. It should have a rough cut surface across the entire face on both sides. If not, make another rough cut, otherwise proceed to the next step for a finish cut.
- 20) Turn both Cut Depth Micro-meters clockwise one small division to move the cutting tool tips towards the face of the rotor by 0.002 in. Figure 14 illustrates that 0.002 in. is the distance between two of the closest marks.
- 21) Turn the Feed Rate Switch on the Drive Motor Control to 2 (slow feed).
- 22) Press the top (INFEED) of the Feed Direction Switch on the lathe. The lathe cutting tools will automatically feed inward making a finish cut on the rotor. The cutting tools will automatically stop at the setting determined in Step 13 by setting the Auto Infeed Stop button.

One rough cut and one finish cut are normally sufficient for most applications. If not, repeat rough and/or finish cuts as required.



**Figure 14** Cut Depth Micrometer

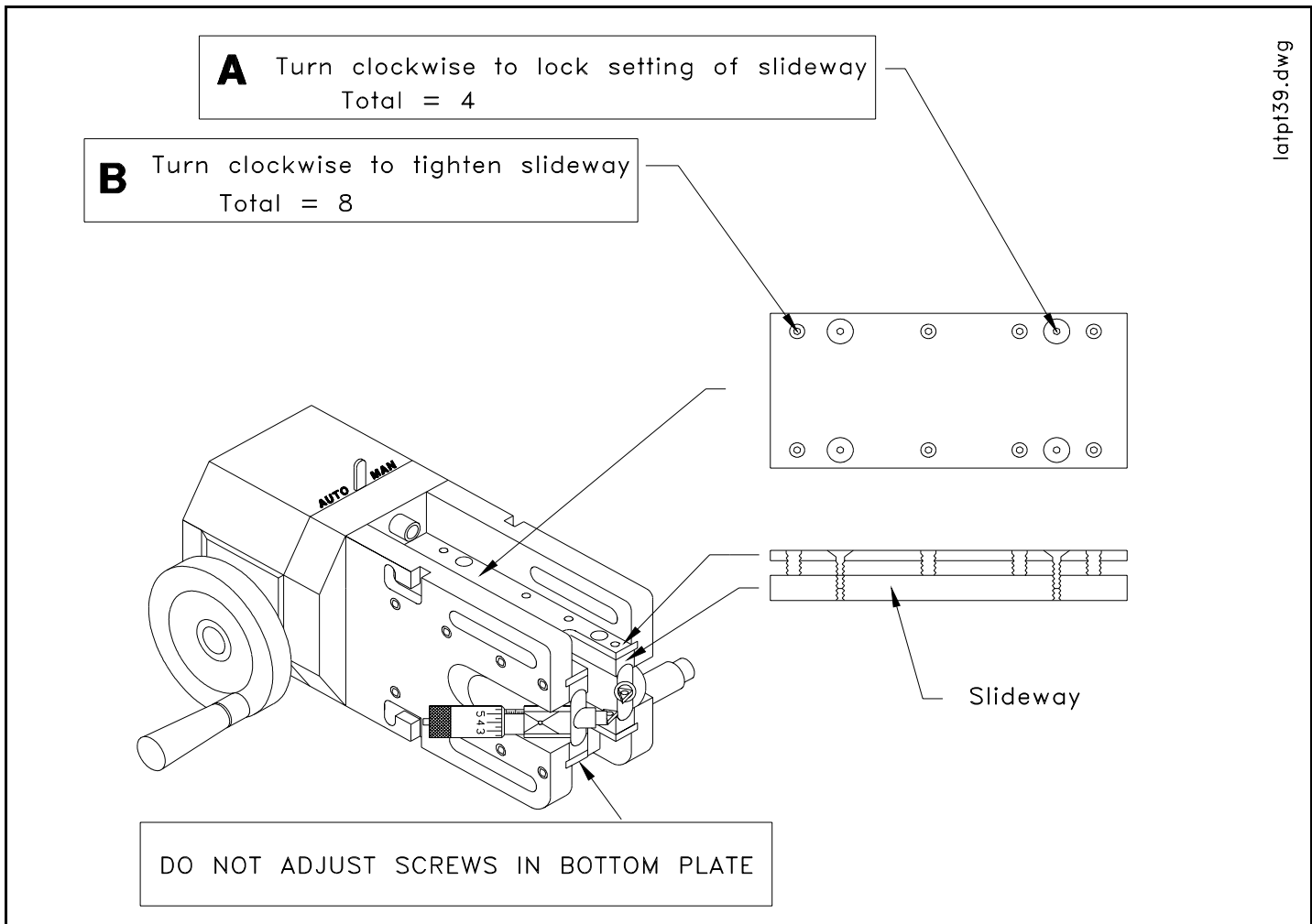
When a satisfactory surface finish has been obtained, press the Safety Lock and move the AUTO/MAN Shift to MANUAL.

Back the cutting tool tips away from the rotor by turning the Cut Depth Micrometers counter-clockwise.

Use the handwheel to back the cutting tools to a position beyond the outer edge of the rotor.

Remove the Lathe and repeat the operation on the other side of the vehicle.

# SLIDEWAY ADJUSTMENT



**Figure 15** Slideway Adjustment

Periodically check the “snugness” of the Tool Holders in the Slideways. When fully extended from the Lathe, there should be no movement of the Tool Holders when pulled up or pushed down. Unsatisfactory surface finish on rotors is often an indication that the Slideways need adjustment.

Carefully study Figure 15 to understand the dynamics of adjusting the tension of the Slideways on the Tool Holders.

- 1) Loosen the eight smaller “B” screws by approximately 1/16 turn.
- 2) Loosen the four larger “A” screws by approximately 1/16 turn.
- 3) Tighten the eight “B” screws evenly to obtain the “snug” feel of the Tool Holders. Check the operation and feel by manually moving the Tool Holders in and out with the handwheel.
- 4) Tighten the four “A” screws to lock the setting of the slideways.

**NOTE: Only the screws in the Top Plate are adjusted. Do not loosen screws in the Bottom Plate**

# SUMMARY

The BRC 35 will provide many years of dependable brake rotor machining with proper care and use.

This manual describes basic operating procedures for quick and easy use of the BRC 35.

As with any fine piece of machinery, experienced operators will quickly discover new and more versatile methods of operation.

The BRC 35 can be set up in various configurations for optimum access to control devices and tool adjustments. No one way is necessarily the best for all vehicles.

Cutting tool heads can easily be removed and re-mounted for reverse cutting applications.

The BRC 35 operates up-side-down just as well as right-side-up. Just remember to set the cutting tools slightly below the centerline of the hub so the rotor turns downward to the cutting tips.

Adaption to special vehicles may require special accessories.